

LEONARDO MATEUS TEIXEIRA DE REZENDE

**COMPARAÇÕES DOS EFEITOS DO ENVELHECIMENTO NA FISIOLOGIA
CARDIOVASCULAR E TERMORREGULATÓRIA EM RATOS WISTAR, WISTAR
KYOTO E ESPONTANEAMENTE HIPERTENSOS DURANTE O REPOUSO E O
EXERCÍCIO FÍSICO AGUDO**

Tese apresentada à Universidade Federal de Viçosa, como parte das exigências do Programa de Pós-Graduação em Educação Física, para obtenção do título *Doctor Scientiae*.

Orientador: Thales Nicolau Prímola Gomes
Coorientadores: Antônio José Natali
Cândido Celso Coimbra

**VIÇOSA – MINAS GERAIS
2020**

Ficha catalográfica elaborada pela Biblioteca Central da Universidade
Federal de Viçosa - Campus Viçosa

T

R467c
2020 Rezende, Leonardo Mateus Teixeira de, 1992-
Comparações dos efeitos do envelhecimento na fisiologia cardiovascular e termorregulatória em ratos Wistar, Wistar Kyoto e espontaneamente hipertensos durante o repouso e exercício físico agudo / Leonardo Mateus Teixeira de Rezende. – Viçosa, MG, 2020.

171 f. : il. (algumas color.) ; 29 cm.

Texto em inglês.

Orientador: Thales Nicolau Primola Gomes.

Tese (doutorado) - Universidade Federal de Viçosa.

Inclui bibliografia.

1. Exercícios físicos - Aspectos fisiológicos. 2. Temperatura corporal - Regulação. 3. Hipertensão. 4. Ratos Endogâmicos SHR. 5. Modelos animais em pesquisa. I. Universidade Federal de Viçosa. Departamento de Educação Física. Programa de Pós-Graduação em Educação Física. II. Título.

CDD 22. ed. 612.044

LEONARDO MATEUS TEIXEIRA DE REZENDE

**COMPARAÇÕES DOS EFEITOS DO ENVELHECIMENTO NA FISIOLÓGIA
CARDIOVASCULAR E TERMORREGULATÓRIA EM RATOS WISTAR,
WISTAR KYOTO E ESPONTANEAMENTE HIPERTENSOS DURANTE O
REPOUSO E O EXERCÍCIO FÍSICO AGUDO**

Tese apresentada à Universidade Federal de Viçosa, como parte das exigências do Programa de Pós-Graduação em Educação Física, para obtenção do título *Doctor Scientiae*.

APROVADA: 18 de dezembro de 2020.

Assentimento:

Leonardo Mateus Teixeira de Rezende
Autor

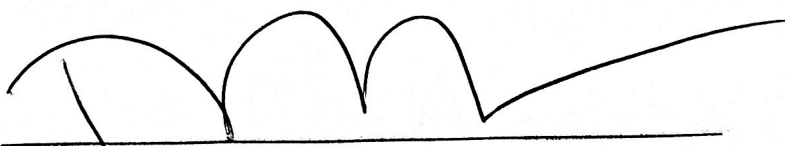
Thales Nicolau Prímola Gomes
Orientador

AGRADECIMENTOS

Agradeço a Deus pela trajetória percorrida, pelas oportunidades e possibilidades que me foram apresentadas, pela fé, força e persistência nos momentos conturbados.

Aos meus pais, Oscar e Lauricea, por todo amor e cuidado. Agradeço por plantarem a semente da curiosidade e representarem fonte de estímulo constante em busca do caminho do estudo, sempre observando valores e princípios que orientam minhas ações.

À minha irmã, Carolina, pelo apoio, incentivo, amizade e presença em todos os momentos importantes.

À Monique, por me acompanhar durante toda minha trajetória dentro da UFV. Agradeço pelo apoio incondicional, pelo cuidado, pela atenção e por ser esta pessoa maravilhosa.

Ao professor Thales Nicolau Prímola Gomes pela cuidadosa orientação em todo meu tempo na pós-graduação, mas principalmente por me abrir os olhos para a verdadeira importância da ciência, assim como para a responsabilidade de fazê-la livre de qualquer sentimento de ego ou vaidade.

Ao professor Antônio José Natali por me abrir as portas do Laboratório de Biologia do Exercício em 2014. Por representar fonte de inspiração quanto a postura profissional e dedicação a ciência.

Ao professor Cândido Celso Coimbra pela Coorientação, por estar sempre a disposição para nos auxiliar nos momentos de dúvida, contribuindo significativamente para o direcionamento e condução do meu trabalho.

A professora Lukiya Silva Campos Favarato por ser a veterinária responsável pelo projeto e por realizar, em conjunto com o professor Evandro Silva Favarato, as cirurgias de implante do sensor nos animais.

A professora Emily Carlo Correna Reis por realizar os exames ecocardiográficos nos animais e por todo auxílio prestado na análise e interpretação dos resultados.

Ao professor Miguel Araújo Carneiro Júnior, que era estudante de pós-doutorado no momento de minha chegada em Viçosa, sendo um dos responsáveis pela minha integração ao laboratório. Agradeço também pela amizade, pelos conselhos, pelo auxílio nos momentos de dúvida e pelas oportunidades apresentadas.

Ao professor Leandro de Campos Brito, pelo auxílio prestado no momento de análise dos resultados do ritmo circadiano. Por se disponibilizar e se envolver no processo de construção deste trabalho.

A professora Maria do Carmo Gouvêa Pelúzio por abrir as portas do laboratório de análise de alimentos no departamento de nutrição para realização de experimentos, bem como ao Ricardo de Britto Antonucci pelo auxílio nestes.

Aos amigos Leôncio, Filipe, Anselmo, Alexandre Martins, Alexandre Costa, Luciano, Franciany, Meilene e Pedro por toda ajuda no cuidado com os animais e nos experimentos, mas também pelos ótimos momentos de convivência, brincadeiras e conversas.

Aos amigos Emanuel, Wanessa, Luciano, Willian, Bruna e Nathalia pela convivência e pelos momentos de estudo, seja pessoal ou virtualmente, no grupo de estudo sobre termorregulação.

Aos amigos Lucas e Tatiane, por todos esses anos de amizade e companheirismo.

À Universidade Federal de Viçosa, minha segunda casa nos últimos 11 anos. Agradeço pela oportunidade e pela estrutura. Estendo meu agradecimento a todos os funcionários e servidores da UFV que se dedicam arduamente para atingir o trabalho de excelência desenvolvido pela instituição.

Aos animais experimentais, parte fundamental para realização da pesquisa. Além do agradecimento, registro também meu respeito.

Ao CNPq e a FAPEMIG pelo apoio financeiro.

O presente trabalho foi realizado com apoio da Coordenação de Aperfeiçoamento Pessoal de Nível Superior - Brasil (CAPES) – código de financiamento 001.

“Talvez não tenha conseguido fazer o melhor, mas lutei para que o melhor fosse feito. Não sou o que deveria ser, mas graças a Deus, não sou o que era antes.”

(Martin Luther King)

RESUMO

REZENDE, Leonardo Mateus Teixeira, D.Sc., Universidade Federal de Viçosa, dezembro de 2020. **Comparações nos efeitos do envelhecimento na fisiologia cardiovascular e termorregulatória em Ratos Wistar, Wistar Kyoto e Espontaneamente Hipertensos durante o repouso e o exercício físico agudo.** Orientador: Thales Nicolau Prímola Gomes. Coorientadores: Antônio José Natali e Cândido Celso Coimbra.

Introdução: O Rato Espontaneamente Hipertenso (SHR) é um modelo experimental amplamente utilizado para o estudo da hipertensão arterial essencial. Contudo, existe um impasse na literatura quanto ao apontamento do modelo a ser utilizado como controle experimental dos SHR, sendo que os ratos Wistar Kyoto (WKY) e os ratos Wistar (WIS) são os mais utilizados. Esta tese foi dividida em quatro capítulos, em que foram realizadas caracterizações dos modelos citados quanto a parâmetros cardíacos e termorregulatórios durante o repouso e durante o exercício físico. *Objetivo:* avaliar os efeitos do envelhecimento sobre variáveis cardíacas e termorregulatórias durante o repouso e exercício físico agudo em Ratos Espontaneamente Hipertensos e seus principais controles experimentais, Wistar e Wistar Kyoto. *Capítulo 1:* foi realizada uma revisão de escopo baseada no método *Preferred Reporting Items for Systematic Reviews and Meta-analysis* (PRISMA), com objetivo de mapear todos os estudos que realizaram qualquer tipo de comparação entre WIS, WKY e SHR. Após a aplicação dos métodos de busca e seleção, 161 artigos foram incluídos para análise, sendo que 68.4% indicaram que ambos os animais normotensos podem ser utilizados como controle dos SHR. Em 13.49% e 6.47% dos estudos, foi indicado os WIS e WKY como melhor controle, respectivamente. *Capítulo 2:* foram avaliados a pressão arterial por meio da pletismografia de cauda e a estrutura e forma cardíaca por meio do ecocardiograma durante o processo de envelhecimento dos animais (16 semanas, 48 semanas e 72 semanas de vida). Foi constatado que para estas variáveis os WIS representam melhor controle, uma vez que os WKY exibiram valores de pressão arterial sistólica próxima ao limiar da hipertensão (WKY: 132 – 146 mmHg; WIS: 116 – 126 mmHg; $p < 0.05$) e perda de função cardíaca antecipada em comparação aos WIS. *Capítulo 3:* avaliou o ritmo circadiano da temperatura central dos animais durante o processo de envelhecimento (16 semanas, 48 semanas e 72 semanas de vida). A medida foi realizada pelo método de telemetria e análises cronobiológica foram aplicadas sobre os dados. Foi encontrado que os SHR possuem disfunções do ritmo circadiano já com 16 semanas, o que foi apontado principalmente pelo maior MESOR (SHR16: 37,49°C; WIS16: 36,50°C; WKY16: 36,44°C; $p < 0.05$), enquanto os animais normotensos apresentaram um aumento do MESOR

com o envelhecimento (WIS16: 36,50°C; WIS72: 37,38°C; WKY16: 36,44°C; WKY72: 37,38°C; $p < 0.05$). Para estas variáveis, foi considerado que ambos os normotensos podem ser utilizados como controle, uma vez que os resultados foram semelhantes. *Capítulo 4:* avaliou as respostas termorregulatórias e o desempenho dos modelos experimentais durante dois protocolos de exercício físico: exercício progressivo até a fadiga e exercício moderado de intensidade constante. Foi encontrado que os SHR com 16 e com 48 semanas apresentam reduzida capacidade de dissipar calor, indicado pela menor temperatura da pele e pelo menor índice para dissipação de calor. Quanto aos animais normotensos, ambos apresentaram perda progressiva da capacidade de dissipar calor com o envelhecimento, sendo que os WIS foram mais afetados nesse sentido. *Conclusão geral:* a revisão de literatura apontou que ambos os animais normotensos são amplamente utilizados como controle dos SHR, sendo que a seleção do modelo deve ser realizada baseada nos objetivos da pesquisa a ser realizada. Este trabalho contribui adicionando mais elementos quanto a caracterização destes. Foi determinado que os WIS são melhor controle para estudos com foco na pressão arterial e na estrutura e função cardíaca. Quanto a trabalhos sobre termorregulação- seja em repouso ou durante o exercício físico- ambos podem ser utilizados, uma vez que os resultados foram bastante semelhantes.

Palavras-chave: Termorregulação. Hipertensão. Modelos experimentais. Rato Espontaneamente Hipertenso.

ABSTRACT

REZENDE, Leonardo Mateus Teixeira, D.Sc., Universidade Federal de Viçosa, December, 2020. **Comparison of aging effects on cardiovascular and thermoregulatory physiology in Wistar, Wistar Kyoto and Spontaneously Hypertensive Rats during rest and acute physical exercise.** Adviser: Thales Nicolau Prímola Gomes. Co-advisers: Antônio José Natali and Cândido Celso Coimbra.

Introduction: The Spontaneously Hypertensive Rat (SHR) is an experimental model widely used for the study of essential arterial hypertension. However, there is an impasse in the literature regarding the designation of the model to be used as SHR control, with Wistar Kyoto rats (WKY) and Wistar rats (WIS) being the most used. This thesis was divided into four chapters, in which characterizations of the models mentioned were made regarding cardiac and thermoregulatory parameters during rest and during physical exercise across aging process of the rats. *Objective:* to evaluate the effects of aging on cardiac and thermoregulatory variables during rest and acute physical exercise in SHR and their main experimental controls, WIS and WKY. *Chapter 1:* a scoping review based on the Preferred Reporting Items for Systematic Reviews and Meta-analysis (PRISMA) method, with the objective of mapping all studies that performed any type of comparison between WIS, WKY and SHR. After applying the search and selection methods, 161 articles were included for analysis, with 68.4% indicating that both normotensive animals can be used as control of the SHR. In 13.49% and 6.47% of the studies, WIS and WKY were indicated as the best control, respectively. *Chapter 2:* blood pressure was assessed by tail plethysmography and cardiac structure and function by means of echocardiography during the animals' aging process (16 weeks, 48 weeks and 72 weeks of life). It was found that for these variables the WIS represent better control, since the WKY exhibited values of systolic blood pressure close to the threshold of hypertension (WKY: 132 - 146 mmHg; WIS: 116 - 126 mmHg; $p < 0.05$) and loss of early cardiac function compared to WIS. *Chapter 3:* assessed the circadian rhythm of the core temperature during the aging process of the rats (16 weeks, 48 weeks and 72 weeks of life). The measurement was performed using the telemetry method and chronobiological analyzes were applied to the data. It was found that the SHR have dysfunctions of the circadian rhythm at 16 weeks, which was pointed out mainly by the largest MESOR (SHR16: 37.49 °C; WIS16: 36.50 °C; WKY16: 36.44 °C; $p < 0.05$), while normotensive animals showed an increase in MESOR with aging (WIS16: 36.50 °C; WIS72: 37.38 °C; WKY16: 36.44 °C; WKY72: 37.38 °C; $p < 0.05$). For these variables, it was considered that both normotensive individuals can be used as a control, since the results were

similar. *Chapter 4:* evaluated the thermoregulatory responses and the performance of the experimental models during two physical exercise protocols: progressive exercise until fatigue and moderate exercise of constant intensity. It was found that SHR at 16 and 48 weeks have a reduced ability to dissipate heat, indicated by the lower skin temperature and the lower index for heat dissipation. As for normotensive animals, both showed progressive loss of the ability to dissipate heat with aging, and WIS were more affected in this regard. *General conclusion:* the literature review pointed out that both normotensive animals are widely used as control of SHR, and the model selection must be performed based on the research objectives to be carried out. This work contributes by adding more elements regarding their characterization. It has been determined that WIS are the best control for studies focusing on blood pressure and cardiac structure and function. As for studies on thermoregulation - either at rest or during physical exercise - both can be used, since the results were quite similar.

Keywords: Thermoregulation. Hypertension. Experimental models. Spontaneously Hypertensive Rat.

LISTA DE SIGLAS E ABREVIATURAS

- AA- *arachidonic acid*
- ACE- *Angiotensin-converting enzyme*
- ACTH- *Adrenocorticotropic hormone*
- ADHD- *attention deficit hyperactivity disorder*
- ANF- *Atrial natriuretic factor*
- ANG-2- *Angiotensin II*
- ANP- *atrial natriuretic peptide*
- AT1Rs- *ANG II type 1 receptors*
- AT2Rs- *ANG II type 2 receptors*
- BM- *Body mass*
- C/EBP- *CCAAT-enhancer binding proteins*
- Ca²⁺- *Calcium*
- CAPES- *Coordenação de Aperfeiçoamento de Pessoal de Nível Superior*
- CCI- *Coluna de células intermediolaterais*
- CD- *Corno dorsal*
- CEUA- *Animal Use Ethics Commission*
- cGMP- *Cyclic guanosine monophosphate*
- CNPq- *Conselho Nacional de Desenvolvimento Científico e Tecnológico*
- COX- *Cytochrome oxidase*
- Cry- *Crythochrome*
- CT- *Continuous test*
- CV- *Corno ventral*
- DBP- *Diastolic Blood pressure*
- Dyn-A- *Dynorphin-A*
- EAH- *Essential arterial hypertension*
- EC- *Exercise capacity*
- EF- *Ejection fraction*
- ET-1- *Endothelin 1*
- ET-3- *Endothelin 3*
- FAPEMIG- *Fundação de Amparo à Pesquisa do Estado de Minas Gerais*

FS- *Shortening fraction*

FTs- *Fixed time schedules*

g- *grama/gram*

GABA- *Neurotransmissores GABAérgicos*

GLU- *Glutamato*

GRK- *G-protein– coupled receptor kinase*

HA- *Hipertensão arterial*

HD- *Hipotálamo dorsomedial*

HL- *Hipotálamo lateral*

HLI- *Heat loss index*

IVSd- *Interventricular septum in diastole*

IVSs- *Interventricular septum in systole*

J- *Joule*

K⁺- *Potassium*

LVDd- *Left ventricle diameter in diastole*

LVDs- *Left ventricle diameter in systole*

LVM- *Left ventricle mass*

LVM/BM- *Left ventricular/body mass ratio*

MAP- *Mean arterial pressure*

Mesh- *Medical Subject Headings*

mmHg- *Milímetro de mercúrio/Milimeter of mercury*

MMP- *Metalloproteinase*

MTF- *Maximal test until fatigue*

MVR- *medula ventrolateral rostral*

η^2 - *Eta squared*

Na⁺- *Sodium*

NaCl- *Sodium chloride*

NE- *Norepinephrin*

NO- *Oxid nitric*

NPL- *Núcleo parabraquial lateral*

NPLd- *Subdivisão dorsal do núcleo parabraquial lateral*

NPLle- *Subdivisão lateral externa do núcleo parabraquial lateral*

NPR- *Núcleo pálido da rafe*

NTC- *Neurônios termo-sensíveis ao calor*

NTS- *Núcleo do trato solitário*

PAD- *Pressão arterial diastólica*

PAM- *Pressão arterial média*

PAS- *Pressão arterial sistólica*

PDGR- α R- *Platelet-derived growth factor- α receptor*

PER- *Period*

POA- *Área pré-ótica do hipotálamo*

POAm- *Área pré-ótica medial do hipotálamo*

POAmd- *Área pré-ótica mediana do hipotálamo*

POAvl- *Porção ventral da área pré-ótica lateral do hipotálamo*

PRISMA- *Preferred Reporting Items for Systematic Reviews and Meta-analysis*

PVH- *Paraventricular nuclei*

PWd- *Posterior wall thickness in diastole*

RMP- *Rest membrane potentials*

RVLM- *Ventrolateral medullary pressor area*

SBP- *Systolic Blood pressure*

SD- *Standard deviation*

SHR- *Rato espontaneamente hipertenso/Spontaneously Hypertensive Rat*

SIP- *Schedule-induced polydipsia*
SON- *Supraoptic nuclei*
SQN- Núcleo supraquiasmático
TAM- Tecido adiposo marrom
T_{amb}- *Ambient temperature*
T_{central}- Temperatura central
T_{core}- *Core temperature*
T_{corporal}- Temperatura corporal
TGF-β1- *Fator de crescimento transformador beta 1*
T_{pele}- Temperatura da pele
TRH- Trato retino-hipotalâmico
TRP- *Transient receptor potential channel*
T_{skin}- *Skin temperature*
USA- *United states*
VMSC- *Vascular muscle smooth cells*
WIS- Wistar
WKY- Wistar Kyoto
α-MHC- *Myosin heavy chain*
°C- Grau Celsius
5HT- *Serotonin*
6-OHDA- *6-hydroxydopamine hydrochloride*

LISTA DE FIGURAS

Introdução:

- Figura 1.** Remodelamento vascular hipertrófico e eutrófico. Adaptado de Sanoyama et al., 2007. ----- 20
- Figura 2.** Canais de potencial receptor transitório (TRPs). Imagem adaptada de Romanovsky (2007). ----- 24
- Figura 3.** Condução neuronal aferente. RGD- raiz de gânglio dorsal; TRPM8- Membro da subfamília M do canal potencial de cátions do receptor transitório 8; TRPV1- O membro transitório 1 da subfamília V do canal de cátions em potencial do receptor transitório; GN- gânglio nodoso; CD- corno dorsal; NTS- núcleo do trato solitário; NPLd- subdivisão dorsal do núcleo parabraquial; NPLle- subdivisão lateral externa do núcleo parabraquial; POAmd- área pré-ótica mediana do hipotálamo; POAm- área pré-ótica medial do hipotálamo; GLU- glutamato . Imagem adaptada de Madden e Morrison (2019). ----- 26
- Figura 4.** Condução neuronal eferente. TAM- tecido adiposo marrom; VC- vasoconstrição; VD- vasodilatação; POAm- área pré-ótica medial do hipotálamo; POAmd- área pré-ótica mediana do hipotálamo; POAvl- porção ventral da área pré-ótica lateral; HD- hipotálamo dorsal; HL- hipotálamo lateral; NPR- núcleo pálido da rafe; MVR- medula ventrolateral rostral; NSS- núcleo salivatório superior; CV- corno ventral; CCI- células da coluna intermediolateral. Imagem adaptada de Madden e Morrison (2019) ----- 28
- Figura 5.** Imagem representativa do sistema de controle circadiano. Após estímulo de luz captado pela retina, o sinal fótico é conduzido ao núcleo supraquiasmático (SQN) via trato retinohipotalâmico (TRH). É iniciado um loop de feedback negativo no SQN, em que as proteínas *Bmal1* e *Clock* se ligam e induzem a tradução de proteínas responsáveis pelo controle de diferentes variáveis circadianas. Ainda, o complexo *Bmal1/Clock* promove a transcrição-tradução das proteínas *Period* (PER) e *Cryptochrome* (Cry) após ausência do sinal fótico, que por sua vez se ligam e inibem o complexo *Bmal1/clock*, finalizando o ciclo circadiano, que será reiniciado após novo sinal de luz. Imagem adaptada de Nakao, Nakamura e Shibata, 2015 e Durrington *et al.*, 2013) ----- 31
- Figura 6.** Pressão arterial sistólica (PAS) e frequência cardíaca (FC) de ratos normotensos Wistar Kyoto (painel A) e temperatura corporal de ratos normotensos Long-Evans (painel B) durante quatro dias. Imagem adaptada de Lemmer et al. (2003) e Reffinetti (2003). ----- 33

LISTA DE TABELAS

Capítulo 1:

Table 1. Laboratories of experimental strains origin. ----- 54

Table 2. Characterization of Wistar, Wistar Kyoto and SHR. ----- 56

Capítulo 2:

Table 1. Long term behavior of morphological and functional echocardiographic parameters of WIS, WKY and SHR with 16, 48 and 72 weeks. ----- 1289

Capítulo 3:

Table 1. Cosinor analysis of the T_{core} circadian rhythm. ----- 149

Capítulo 4:

Table 1. Body mass and blood pressure measurements. ----- 162

SUMÁRIO

Introdução:

1- Introdução:.....	18
1.1- Hipertensão arterial:.....	19
1.2- Termorregulação:.....	22
1.3- Ritmo circadiano:	29
1.4- Envelhecimento:	33
1.5- Exercício físico:.....	34
1.6- O paradigma experimental:	36
2- Objetivos:	38
2.1- Geral:.....	38
2.2- Específicos:.....	38
3- Referências:.....	38

Capítulo 1:

1- Introduction:	47
2- Methods:.....	49
3- Results:.....	50
4- Discussion:.....	103
5- References:	108

Capítulo 2:

1- Introduction:	120
2- Methods:.....	121
3- Results:.....	122
4- Discussion:.....	129
5- Conclusions:	131
6- References:	132

Capítulo 3:

1. Introduction.....	138
2. Materials and methods	140
3. Results	142
4. Discussion.....	150

5. Conclusions.....	153
6. Acknowledgments.....	153
7. References.....	154

Capítulo 4:

1- Introduction:	158
2- Materials and Methods:.....	159
3- Results:.....	160
4- Discussion:.....	168
5- Conclusions:	169
6- References.....	170

1- Introdução:

A população mundial experimentou um processo evolutivo constante que impactou diferentes áreas da sociedade, incluindo no combate a doenças (1). Este fato levou a criação do conceito de transição epidemiológica- uma teoria que explica a dinâmica dos padrões de saúde e mortalidade em função da evolução- que leva em consideração fatores sociais, demográficos e econômicos (2). Existem três estágios bem definidos de acordo com esta teoria: a) idade da pestilência e fome; b) idade do declínio das pandemias e; c) idade das doenças crônicas degenerativas e provocadas pelo homem (3).

O período da pestilência e fome durou até o fim da idade média e tinha como característica altas taxas de natalidade e mortalidade, sendo que a expectativa de vida era de aproximadamente 30 anos. Foi marcado por grande incidência de mortes decorrentes da desnutrição e pandemias (1). A idade do declínio das pandemias teve duração da renascença até a revolução industrial, marcada pelo aumento da expectativa de vida para 40 anos. Houve um declínio das pandemias, sendo as doenças infecciosas a principal causa de morte. Da revolução industrial até o século XX o mundo vivenciou a idade das doenças degenerativas e provocadas pelo homem. O desenvolvimento levou a maior disponibilidade de alimentos e melhores condições de moradia e saneamento e, conseqüentemente, à redução das doenças infecciosas. Dessa forma, a expectativa de vida aumentou exponencialmente e as doenças crônicas degenerativas passaram a ser o principal risco a saúde mundial (1-3).

Posterior a estes três estágios a sociedade seguiu em processo evolutivo acelerado, devido ao desenvolvimento industrial e tecnológico, indicando maior dinâmica das etapas que caracterizam a saúde/mortalidade da população mundial. Deste modo, já são apontados dois novos estágios: d) idade das doenças degenerativas atrasadas e; e) idade das infecções emergentes e re-emergentes. A primeira é caracterizada pelo aumento da expectativa de vida de indivíduos com doenças crônicas degenerativas em função da melhora nos tratamentos, e a segunda associada ao ressurgimento de doenças parasitárias (3).

O avanço técnico-científico trouxe aumento da longevidade, no entanto, novos desafios surgiram para as ciências da saúde (3, 4). Apesar do grande esforço e alta fomentação pública no combate às doenças cardiovasculares, estas seguem como uma das principais causas de mortalidade mundial (5-9). Um estudo apontou que em 2013 houveram mais de 54 milhões de mortes no mundo, sendo que 17 milhões (32%) foram atribuídas aos distúrbios cardiovasculares (10). Entre as doenças cardiovasculares com maior incidência a nível mundial está a hipertensão arterial (HA), sendo que esta apresenta prevalência acentuada na América Latina, que em sua

composição predomina países emergentes, que são os que exibem maior incidência da HA (9, 11).

No Brasil existem estudos com extensa abrangência territorial que apontam alta incidência da HA (12-16). Andrade e colaboradores realizaram um levantamento da prevalência de HA autorreferida em todas regiões geográficas do Brasil no ano de 2013, em que foram entrevistadas 60202 pessoas. Os autores informaram que 21,4% da população avaliada possuía o diagnóstico de HA (12). Um segundo trabalho analisou a prevalência da HA no Brasil nas últimas três décadas (1980-2010) e concluiu que apesar de haver uma redução de 6% dentro deste período, a patologia ainda está presente em aproximadamente 30% da população (13). As informações apresentadas destacam a HA como uma das patologias contemporâneas de maior acometimento e diretamente relacionada a taxa de mortalidade a nível nacional e mundial. Portanto, pesquisas a respeito desta temática possuem grande relevância e contribuem para a prevenção, diagnóstico e tratamento da doença.

1.1- Hipertensão arterial:

A HA é caracterizada pelo aumento sustentado da pressão sanguínea nas artérias acima dos níveis normais (17-19). Apesar de existirem informações a respeito de fatores que predisõem à HA- como histórico familiar, alta ingestão de sódio, sedentarismo, etc.- na maioria dos casos a doença não apresenta causa identificável, sendo rotulada como HA primária ou essencial, englobando aproximadamente 95% dos casos (20, 21). Este distúrbio afeta profundamente os dois componentes estruturais do sistema cardiovascular, coração e vasos sanguíneos, e frequentemente é associado ao surgimento de outros problemas como a insuficiência cardíaca e renal (18, 22).

Existe uma categorização da pressão arterial de acordo com os valores mensurados. Entre os humanos, é considerado normal o indivíduo que apresenta valores abaixo de 120/80 mmHg (Pressão arterial sistólica- PAS/Pressão arterial diastólica- PAD); àqueles com valores de 120-129/<80 mmHg são classificados com pressão arterial elevada; os com 130-139/80-89 mmHg são considerados hipertensos no estágio 1; e indivíduos acima de 140/90 mmHg são classificados como hipertensos no estágio 2 (17, 19). Já entre os animais experimentais, especificamente para os roedores, a hipertensão é classificada como PAS acima dos 150 mmHg (23).

A resistência vascular periférica aumentada é uma característica clássica da HA, ocorrendo principalmente na porção distal das artérias e arteríolas (20). A resistência vascular periférica é determinada principalmente pelo diâmetro do lúmen dos vasos. Existem duas

teorias para explicar este fenômeno: rarefação e remodelamento (17, 20). O processo de rarefação é a redução da densidade de vasos por área, sendo que pode ser dividido em rarefação estrutural, que indica uma redução real na quantidade de vasos e a rarefação funcional, que representa menor irrigação dos vasos (24). O remodelamento vascular é um processo de modificação estrutural que envolve crescimento, morte e migração celular, além de síntese e degradação de matriz extracelular e ocorre após estímulos como modificação hemodinâmica (25). É um processo extremamente importante para a saúde cardiovascular e acontece de maneira ininterrupta, o que quer dizer que a estrutura dos vasos é modificada constantemente a fim de atender as demandas sanguíneas em adequada quantidade e pressão (20). Contudo, o remodelamento imposto pela HA leva a um quadro de insuficiência vascular devido ao desequilíbrio imposto por prevalência de fatores de crescimento endotelial, como TGF- β 1, colágeno e elastina (26, 27). É importante ressaltar que ambos os mecanismos contribuem para instalação de uma resistência vascular periférica aumentada e, conseqüentemente, para patogênese da HA. Estes acometimentos são danosos à estrutura e ao funcionamento vascular, atuando ainda como fator de risco para uma série de outros distúrbios cardiovasculares como aterosclerose e infarto do miocárdio (25).

O remodelamento vascular provocado pela hipertensão pode ocorrer de duas maneiras, o remodelamento eutrófico e hipertrófico. O eutrófico é uma alteração estrutural induzida por processo hipertensivo menos severo ou inicial, em que ocorre espaçamento das paredes concomitante à redução do diâmetro do lúmen, e aumento da razão parede/lúmen, no entanto, a área de secção transversa é conservada (28). É uma resposta que objetiva a manutenção da função dos vasos, sendo que o tônus miogênico possui papel determinante. O tônus miogênico é uma importante função das pequenas artérias, caracterizado pela capacidade de constrição após o aumento da pressão intraluminal (29). Quando a pressão hemodinâmica supera o limite suportado pela parede das artérias ocorre a quebra do tônus miogênico, levando a uma dilatação forçada (30). Nesse momento é iniciado o processo de remodelamento vascular patológico, em que ocorre aumento das paredes vasculares e redução do diâmetro do lúmen, associado ao aumento da secção transversa dos vasos (28, 31).



Figura 1. Remodelamento vascular hipertrófico e eutrófico. Adaptado de Sanoyama et al., 2007.

Este rearranjo da geometria vascular contribui para a evolução da doença, uma vez que afeta profundamente a hemodinâmica, aumentando a sobrecarga de pressão imposta ao coração.

Assim como os vasos, o coração também é afetado pela HA, sendo importante considerar que as alterações estruturais e funcionais dos cardiomiócitos ocorrem posterior ao desequilíbrio hemodinâmico (32, 33). O miocárdio é composto por cardiomiócitos, vasos sanguíneos e matriz extracelular. A estrutura e função do coração dependem do equilíbrio entre estes componentes, sendo que alterações ocorrem continuamente em função dos diferentes estímulos (33, 34). Como já visto, a HA promove sobrecarga hemodinâmica de pressão, levando a maior quantidade de sarcômeros dispostos em paralelo, originando hipertrofia concêntrica patológica do ventrículo esquerdo (33).

Uma delicada rede tridimensional de colágeno envolve os cardiomiócitos a fim de oferecer uma estrutura de suporte, todavia, a HA leva ao aumento de colágeno na matriz extracelular (35). Dessa forma, o coração do hipertenso apresenta um desequilíbrio em que os componentes extracelulares aumentam desproporcionalmente em relação aos cardiomiócitos (36). Estudos confirmam que hipertensos apresentam maior quantidade de colágeno tipo I e III nas artérias coronarianas (37, 38), sendo que a sobrecarga mecânica funciona como mecanismo de disparo para aumento da síntese de colágeno (39, 40). Aliado a isto, a maior proporção de tecido fibroso interfere na condução do impulso elétrico do miocárdio, podendo originar, por exemplo, arritmias (37).

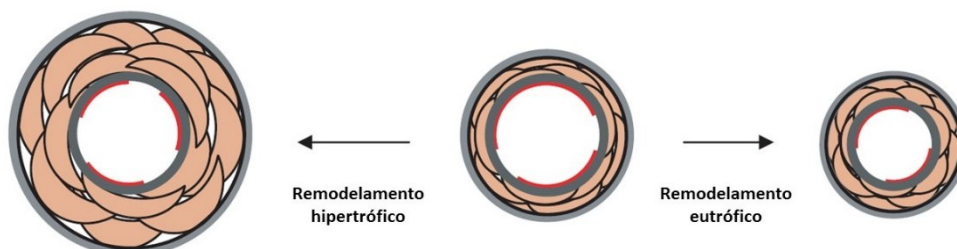
A quantidade de colágeno na matriz extracelular depende do equilíbrio na atividade das estruturas responsáveis pela síntese e degradação deste (41). O sistema renina-angiotensina-aldosterona funciona como precursor da síntese de colágeno no miocárdio, estimulando a ação dos fibroblastos, enquanto as enzimas do grupo metaloproteinases são responsáveis pela degradação (36, 37). Sabe-se, no entanto, que a HA promove um desequilíbrio entre estes processos, promovendo maior síntese de colágeno (35), sendo que a instalação da fibrose promove redução do fluxo sanguíneo coronariano, bem como enrijecimento do tecido, redução da distensibilidade, redução do enchimento ventricular e, conseqüentemente, disfunção diastólica (37, 39, 42).

O impacto da HA no miocárdio é caracterizado por estágios bem definidos (33, 43). Inicialmente ocorre a fase compensada, em que o coração responde a sobrecarga de pressão aumentando a espessura das paredes concomitante à redução do diâmetro do ventrículo esquerdo, possibilitando gerar maior pressão no momento da ejeção sanguínea, a fim de vencer a resistência vascular periférica aumentada (41, 44). Este rearranjo estrutural ocorre como tentativa compensatória de reduzir o estresse na parede das cavidades, bem como promover a

manutenção da função sistólica. No entanto, o estímulo aplicado pela HA é crônico, de forma que o tecido torna-se incapaz de normalizar o estresse imposto, o que, aliado ao desenvolvimento da disfunção diastólica e aumento da fibrose, levam à instalação da fase descompensada (34).

A doença atinge a fase descompensada quando as alterações estruturais prejudicam a funcionalidade dos cardiomiócitos. A literatura aponta mecanismos responsáveis pela descompensação na hipertensão (45, 46). Ocorre modificação na expressão dos genes reguladores da função contrátil, como a miosina de cadeia pesada, acompanhado do avançado estágio de fibrose, podendo levar a disfunção sistólica. Relatos apontam também para apoptose de cardiomiócitos induzida pela hipertensão, colaborando para o desequilíbrio entre células cardíacas e tecido fibroso (46-48).

O sistema cardiovascular é determinante para a manutenção de uma série de funções do organismo, incluindo o controle termorregulatório. Tal controle se dá por meio de ajustes no débito cardíaco e volume de ejeção quando é necessária regulação na circulação sanguínea, aliado ao controle do tônus vascular, participando diretamente dos processos de dissipação e retenção de calor (141). Dessa forma, patologias que afetam a forma e função dos componentes do sistema cardiovascular podem alterar o controle termorregulatório (142). Por exemplo, A HA pode influenciar estes mecanismos de controle vascular devido ao aumento da resistência vascular periférica (142). Dessa forma, pesquisas científicas sobre a associação da HA a variáveis termorregulatórias possuem relevância, uma vez que o controle termorregulatório é determinante para manutenção da vida.

1.2- Termorregulação:

A termorregulação representa o controle da temperatura corporal (T_{corporal}), mesmo com grande variação da temperatura ambiente, sendo que o balanço térmico ocorre por meio dos processos de produção e perda de calor (115). O ajuste termorregulatório acontece continuamente objetivando manter a homeostase térmica frente aos diferentes desafios, uma vez que até pequenos movimentos corporais podem promover modificações metabólicas e, conseqüentemente, na produção de calor (116, 117).

Os mamíferos são classificados como homeotérmicos, o que significa que seu corpo representa sua fonte primária de calor (118). A T_{corporal} desta classe de animais é mantida em uma estreita faixa de variação, próxima aos 37°C, e desvios acentuados promovem respostas

termorregulatórias comportamentais e/ou autonômicas visando o reestabelecimento de valores estáveis (119).

A termorregulação desempenha papel central no organismo, sendo determinante para o funcionamento de uma série de órgãos e tecidos em nível central e periférico (118). Sua manutenção ocorre por meio de ação integrativa entre os seguintes componentes: agentes receptores, canal aferente, centro controlador, canal eferente e órgãos efetores. O centro controlador é localizado na área pré-ótica do hipotálamo (POA)- local de integração sensório-motor (118, 120)- que tem seus comandos baseados em informações recebidas via aferente e executados por órgãos efetores (118, 121, 122). Tal ação integrativa utiliza como base principalmente as temperaturas central (T_{central}) e da pele (T_{pele}). A T_{central} é fortemente estável e reflete a T_{corporal} profunda, incluindo órgãos e tecidos, enquanto a T_{pele} representa a T_{corporal} periférica, que é intensamente influenciada pelo fluxo sanguíneo e tônus vascular, bem como pela temperatura ambiente externa ao corpo, sendo sujeita a maior variação (123).

A POA é responsável por administrar as ações destinadas à manutenção da homeostase termorregulatória (124), sendo que uma rede de neurônios nela contidos regulam a temperatura dentro da faixa de variação aceitável (36-38°C). Assim, quando a região da POA é aquecida estes neurônios termo-sensíveis são despolarizados e conseqüentemente aumentam sua frequência de disparo, atuando no sentido de aumentar as ações promotoras de perda de calor (125). Sabe-se que existe uma comunicação entre o centro controlador e as regiões periféricas corporais, uma vez que estudos apontam que modificações na T_{pele} geram respostas imediatas na POA, visando antecipar possível variação da T_{central} (126). Por exemplo, quando a pele de ratos é resfriada, a termogênese do tecido adiposo marrom (TAM) é ativada via estimulação simpática a fim de evitar que o resfriamento atinja regiões corporais centrais (122). Tratam-se, portanto, de respostas termorregulatórias defensivas, induzidas pela detecção de modificações da temperatura ambiente. Estas respostas acontecem por meio de termorreceptores espalhados nas terminações nervosas sensoriais primárias distribuídas na pele com direta transmissão para a POA (120).

As informações térmicas são captadas por canais receptores de ação dependente de temperatura (*transient receptor potential channel- TRP channels*). Estes aparecem espalhados na pele para aferição da influência ambiente, bem como em vários órgãos e tecidos, para determinação de temperatura local (124). As informações são direcionadas ao centro controlador via neurônios aferentes, mais especificamente pela via *espino-parabraquial-hipotalâmica* (118, 124). Os canais termorreceptores são divididos entre aqueles sensíveis ao calor (TRPM2, TRPM4, TRPM5, TRPV1, TRPV2, TRPV3 e TRPV4) localizados

predominantemente em regiões centrais do corpo, e os sensíveis ao frio (TRPA1 e TRPM8), encontrados principalmente abaixo da epiderme, sendo considerados receptores periféricos (fig.4) (118, 127). Os canais TRP são ativados quando a temperatura a qual estão expostos atingem seu limiar para despolarização de membrana (118). É importante ressaltar que eles respondem dentro de uma faixa de variação de temperatura, podendo inclusive atuar de maneira sobreposta.



Figura 2. Canais de potencial receptor transitório (TRPs). Imagem adaptada de Romanovsky (2007).

O processo de comunicação aferente é iniciado nos canais TRP, que têm seus corpos neuronais inseridos nos gânglios de raiz dorsal da medula espinhal, que por sua vez projeta-se para o corno dorsal (CD), acessando principalmente a lâmina I (128). Contudo, as vias de sinalização percorridas pelos estímulos de frio e de calor são distintas, iniciando pelo tipo de fibra neural associada. As fibras nervosas do tipo A e C são responsáveis pela condução do estímulo de frio, enquanto apenas as fibras tipo C conduzem o estímulo de calor (129-131). O CD tem neurônios que se estendem para o núcleo parabraquial lateral (NPL), sendo este ativado tanto por vias de calor, como de frio, iniciadas na pele (132). Os neurônios do NPL ativados pelo frio estão localizados predominantemente na subdivisão lateral externa do NPL (NPLle), os quais recebem informações do CD e projetam para a área pré-ótica mediana do hipotálamo (POAmd). Já os impulsos de calor são recebidos pela subdivisão dorsal do NPL (NPLd), que providencia comunicação com a POAmd (fig.4). É importante ressaltar que o principal neurotransmissor envolvido na condução da informação aferente, tanto para o frio, como para o calor, é o glutamato (132).

As vias aferentes contam ainda com a contribuição da percepção sensorial térmica abdominal, espinhal e cerebral (124, 132, 133). Sabe-se que modulações da temperatura abdominal induzem modificação de respostas termofetoras como a produção de suor e os tremores (124, 133). Tal percepção aferente é iniciada no nervo vago dos gânglios nodosos, que conduzem a informação até o núcleo do trato solitário (NTS), que por sua vez, realizam sinapse no NPLd, promovendo a continuidade do trajeto neuronal, objetivando atingir a POA e alcançando, portanto, a regulação das respostas termofetoras (fig.4) (124, 132). A nível medular, os canais TRP estão localizados principalmente nas fibras somatossensoriais do CD (124). Estes funcionam ainda como regulador da informação oriunda da periferia, promovendo a integração com sua própria percepção e então transmissão para a POA. Esta função é particularmente importante em ambientes extremos, uma vez que a pele é altamente influenciável, podendo emitir informações descomedidas (124).

Especificamente na POA, existe predominância de neurônios termo-sensíveis ao calor (NTC), sendo que estes aumentam sua taxa de disparo após aquecimento local (118, 132). Estes atuam promovendo a integração dos sinais periféricos oriundos da pele e das vísceras com a temperatura cerebral e, na condução neuronal de saída termofetora na área pré-ótica medial (POAm) (132). O influxo referente ao calor promove a estimulação destes NTC, dando continuidade ao início de respostas termofetoras adequadas a perda de calor. Entretanto, quando é chegado influxo de informação oriunda de estímulo de frio das periferias, a primeira resposta é a inibição da neurotransmissão destes mesmos NTC, o que destaca sua relevância no controle termorregulatório (fig.5) (132, 134).

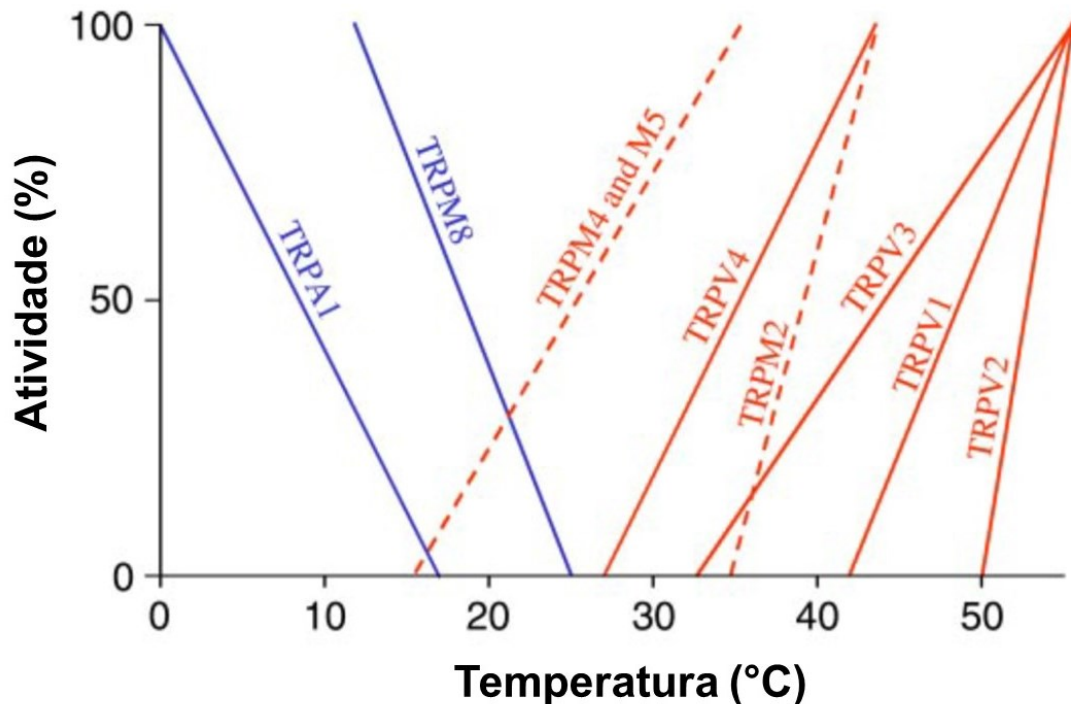
As informações até aqui apresentadas indicam que a percepção térmica dos homeotérmicos é considerada assimétrica, uma vez que existe maior concentração de canais TRP sensíveis ao calor, bem como predominância em termos de quantidade e atividade de NTCs no controle central (118). Tal fato justifica-se pela T_{central} estar próxima aos limites superiores suportados pelo organismo, existindo portanto maior necessidade de controle sobre o aumento da temperatura (118, 127). Por outro lado, existe maior margem para redução da T_{central} , já que esta é fixada em maior distância do limite inferior, sendo este o principal motivo pela reduzida quantidade de neurônios termorreceptores sensíveis ao frio (118).



Figura 3. Condução neuronal aferente. RGD- raiz de gânglio dorsal; TRPM8- Membro da subfamília M do canal potencial de cátions do receptor transitório 8; TRPV1- O membro transitório 1 da subfamília V do canal de cátions em potencial do receptor transitório; GN- gânglio nodoso; CD- corno dorsal; NTS- núcleo do trato solitário; NPLd- subdivisão dorsal do núcleo parabraquial; NPLle- subdivisão lateral externa do núcleo parabraquial; POAm- área pré-ótica mediana do hipotálamo; POAm- área pré-ótica medial do hipotálamo; GLU- glutamato . Imagem adaptada de Madden e Morrison (2019).

As respostas termoeferentes autonômicas dividem-se em categorias: termogênicas, vasomotoras e evaporativas. As respostas termogênicas são voltadas para produção interna de calor, o que inclui a termogênese adaptativa do TAM e a termogênese via tremores. As modificações do tônus vascular, mais especificamente, os processos de vasoconstrição e vasodilatação, compõe as respostas vasomotoras. Por fim, a perda evaporativa de calor, composta pela sudorese para os humanos e a secreção e espalhamento de saliva para os roedores (132). Todos esses mecanismos termoeferentes têm seu início na POA, possuindo como principal via eferente o hipotálamo dorsomedial (HD), seguido do núcleo pálido da rafe (NPR) a nível medular, para então serem encaminhadas para os terminais comunicativos entre a medula espinhal e os órgãos efetores, intermediados pelos gânglios (fig.5) (132). No entanto, existem particularidades que as distinguem.

Quanto a termogênese via TAM e tremores, ocorre transmissão neural da POAm para o HD, que atua como retransmissor, ativando neurônios pré motores do NPR, que dá seguimento a transmissão descendente via neurônios espinhais, alcançando os neurônios pré-ganglionares para a termogênese do TAM e neurônios motores, que promovem estímulo para a termogênese via tremores do músculo esquelético (fig.5). O TAM é um tecido metabolicamente muito ativo e rico em mitocôndrias, o que fornece sua coloração amarronzada. Este representa órgão efector importante em pequenos mamíferos como roedores, mas está

presente também em seres humanos. Já os tremores são contrações involuntárias do músculo esquelético objetivando aumentar a produção de calor (124).

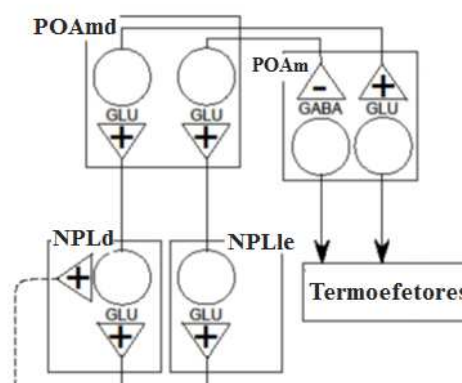
Sabe-se que em ambiente quente existe um comando inibitório simpático oriundo da POA, mais especificamente, da POAm e da porção ventral da área pré-ótica lateral (POAvl), indicando inibição dos neurônios do HD e do NPR via liberação de neurotransmissores GABAérgicos e, por consequência, suprimindo a ativação da termogênese do TAM (135). De maneira semelhante, o ambiente quente indica inibição do circuito neural para termogênese via tremores, entretanto, a inibição oriunda da POAvl atinge apenas os neurônios do NPR (135). Em contraponto, o estímulo de frio, quando na intensidade suficiente, induz a retirada da inibição simpática imposta a POA, dando início a cascata de sinalização para termogênese do TAM e dos tremores (135, 136). O trecho final de ativação do circuito neural do TAM e dos tremores distingue. Enquanto o circuito do TAM apresenta influxo espinhal simpático glutamatérgico e serotoninérgico a nível pré-ganglionar, os tremores são iniciados pela ativação dos neurônios pré-motores somáticos α e γ no corno ventral (CV), que por sua vez, induzem o início da termogênese diretamente no tecido muscular esquelético.

De forma bastante semelhante acontece a via para vasoconstrição, com exceção da retransmissão no HD (fig.5B). A transmissão neural efetora é iniciada na POA e entregue diretamente ao NPR, que promove influxo neural para as células da coluna intermediolateral da coluna toracolombar, ativando os neurônios pré-ganglionares simpáticos, determinando, por fim, a ação de fibras nervosas simpáticas que inervam os vasos cutâneos, ativando a vasoconstrição. Evidências apontam ainda para contribuição da medula ventrolateral rostral (MVR) na comunicação eferente para vasoconstrição, contudo, esta via ainda não está devidamente elucidada (137). O circuito neural para vasodilatação ainda não possui um modelo de consenso na literatura, contudo, sabe-se que o comando central para inibição da vasoconstrição é fator crucial para o início do processo antagonista, ou seja, a vasodilatação (138).



Figura 4. Condução neuronal eferente. TAM- tecido adiposo marrom; VC- vasoconstrição; VD- vasodilatação; POAm- área pré-ótica medial do hipotálamo; POAmd- área pré-ótica mediana do hipotálamo; POAvl- porção ventral da área pré-ótica lateral; HD- hipotálamo dorsal; HL- hipotálamo lateral; NPR- núcleo pálido da rafe; MVR- medula ventrolateral rostral; NSS- núcleo salivatório superior; CV- corno ventral; CCI- células da coluna intermediolateral. Imagem adaptada de Madden e Morrison (2019)

A terceira via eferente é voltada para perda evaporativa de calor, o que engloba a sudorese para os seres humanos e a termorregulação salivatória nos roedores (120, 124, 132). Pouco se sabe sobre o disparo central para produção de suor. Entretanto, as sinapses eferentes estimulam neurônios da área parafacial, seguindo para coluna de células intermediolaterais (CCI), que na sequência, promove comunicação com os neurônios simpáticos pré-ganglionares sudomotores, que ativam as glândulas sudoríparas (120).

Os roedores não possuem o mecanismo de sudoreses, no entanto, utilizam a secreção de saliva seguida do espalhamento desta pela superfície corporal, dissipando, portanto, calor via evaporação da saliva (132). Seu controle central se dá via comando eferente inibitório oriundo da POA para o hipotálamo lateral (HL). A inibição dos neurônios do HL indica ativação dos neurônios do núcleo salivatório superior (NSS), sendo que estes promovem comunicação com

neurônios pré-ganglionares parassimpáticos, que estimulam as glândulas salivares (fig.5C). É importante ressaltar que as vias termoeferentes apresentadas não ocorrem de maneira exclusiva, mas sim em sobreposição.

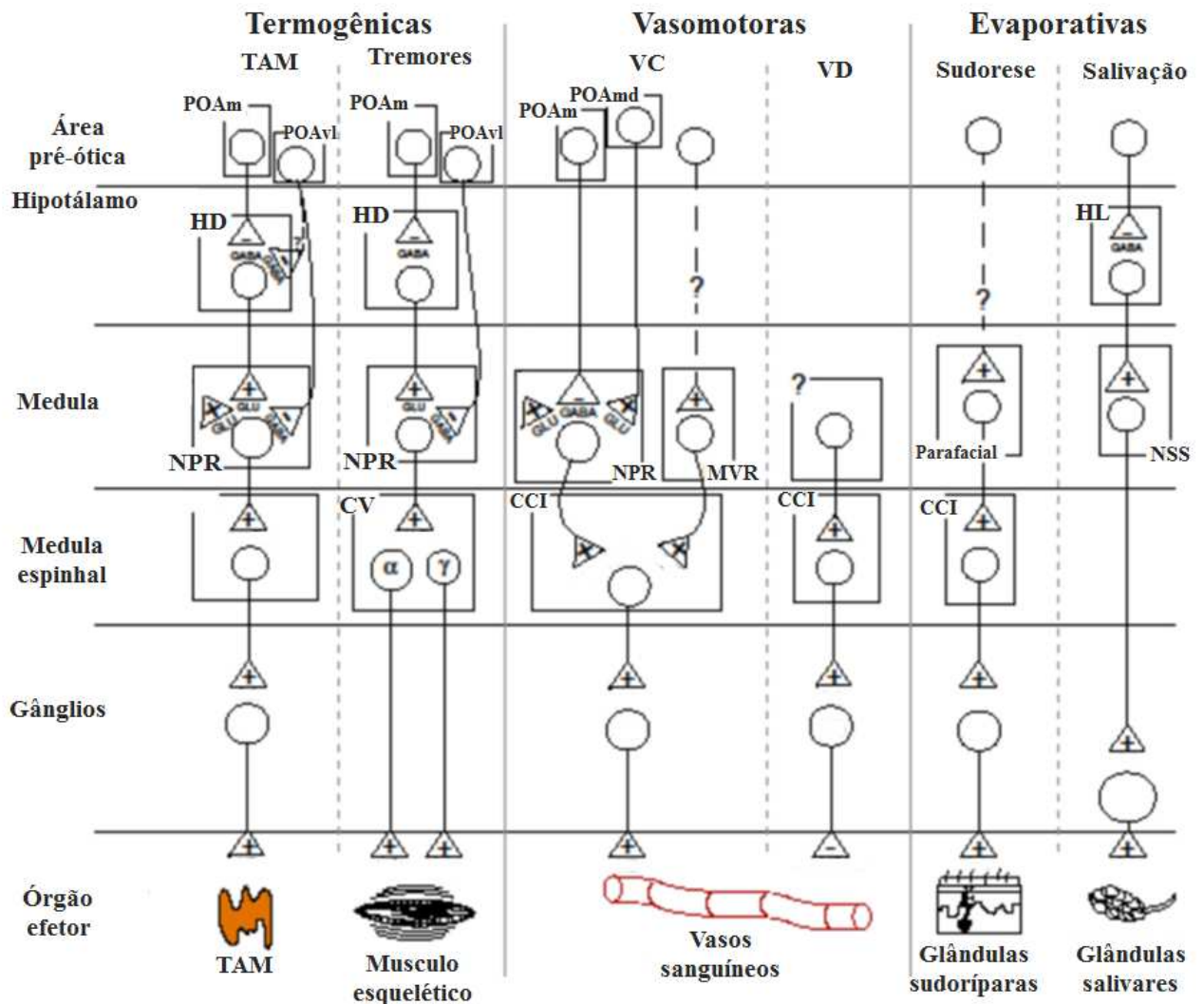
A homeostase térmica não está associada a ausência de variação da T_{central} ao longo do dia ($\sim 36\text{-}38^{\circ}\text{C}$), havendo um padrão de oscilação diário em conformidade com variações geofísicas ambientais, sincronizada principalmente com o ciclo dia/noite (139, 140). Existe um consenso na literatura de que o controle da T_{central} é regulado primariamente pelo ajuste homeostático e em segundo plano pelo sistema circadiano (63). Os mamíferos possuem um ciclo de atividade/repouso, sendo que o pico de T_{central} ocorre na fase de atividade seguido de redução no período de repouso. Humanos tem atividade durante o dia, apresentando aumento da T_{central} neste momento. Em oposição, os roedores são animais de hábitos noturnos, possuindo maior atividade termogênica associada a maior atividade locomotora neste período, exibindo portanto um padrão de oscilação da T_{central} invertido em relação aos humanos (65).

1.3- Ritmo circadiano:

Ritmo circadiano designa um período de aproximadamente 24 horas em que se baseia o ciclo biológico da maioria dos seres vivos em associação a variação geofísica ambiental. Para os mamíferos, o principal regulador externo do ritmo circadiano é o ciclo dia/noite, sendo que a presença de luz ativa fotorreceptores na retina, que por sua vez, indica a condução da informação ao centro controlador (núcleo supraquiasmático- SQN) de forma direta via trato retino-hipotalâmico (TRH; Fig.2), e de forma indireta via trato geniculado-hipotalâmico (49). O SQN- localizado no hipotálamo- recebe a informação e determina a fase circadiana atual, dessa forma, esta estrutura é responsável pela geração, controle e sincronização do ritmo de diversas variáveis do organismo, o que acontece por meio da administração de vias de sinalização neural e hormonal (50).

Além do relógio central, os órgãos periféricos possuem relógios de controle circadiano específico de suas funções, que atuam sob sinalização central (51). Dessa forma, o SQN atua como retransmissor, emitindo a informação oriunda do ambiente externo para os demais tecidos (51, 52). Estes ritmos são criados e controlados através da ação de um conjunto de genes relógio- *Clock*, *Bmal1*, *Period (Per)* e *Cryptochrome (Cry)*- situados a nível central e periférico (52-54). É observado processo interperiódico de ativação/bloqueio da atividade de translação-tradução-atividade dos genes relógio induzido pela flutuação circadiana. Após a chegada do sinal fótico ao SQN, as proteínas *clock* e *Bmal1* se ligam formando um complexo que induz a

expressão genética seguida da tradução de uma série de proteínas envolvidas no controle circadiano. Entretanto, encerrado estímulo de luz, o complexo *Clock/bmall* induz a tradução das proteínas *Per* e *Cry*, que por sua vez quebram a ligação entre as proteínas *Clock* e *Bmall*, encerrando o ciclo. Este mecanismo de feedback negativo permite a oscilação das variáveis circadianas, possibilitando ao organismo antecipar as alterações ambientais, organizando de forma ativa sua fisiologia circadiana (51). Contudo, sabe-se que existem diferentes isoformas dos genes citados, o que provoca particularidades entre espécies (52, 55, 56). Dentre as variáveis que apresentam variação rítmica destacamos aqui a temperatura corporal e parâmetros cardiovasculares como a frequência cardíaca e a pressão arterial (Fig. 3) (57, 58).

Como apresentado, todos os mamíferos estão sujeitos a variação circadiana, no entanto, sabe-se que existem animais de diferentes cronotipos, ou seja, aqueles de hábitos noturnos e os de hábitos diurnos (55, 56). Para o devido entendimento das diferenças entre espécies, se faz necessária a compreensão dos conceitos de “dia e noite subjetivos”, que representam qualitativamente as fases em que ocorrem atividade e repouso, respectivamente. Assim sendo, os roedores que possuem hábitos noturnos, possuem dia subjetivo na fase noturna e noite subjetiva na fase diurna. Surpreendentemente, animais com hábitos opostos apresentam estrutura anatômica semelhante quanto aos componentes responsáveis pelo ritmo circadiano e, ainda mais interessante, quanto as fases de atividade do SQN (59, 60). Dessa forma, o funcionamento do SQN frente ao estímulo de luz é semelhante entre as espécies de diferente cronotipos. No entanto, outros pontos do cérebro são envolvidos no controle circadiano específico (córtex cingulado, parietal e estriado), bem como os órgãos periféricos possuem relógios de controle específicos, sendo que nestes é apontado pico do gene *Per2* invertido em 180° entre as espécies de cronotipos distintos, explicando as diferenças de preferência temporal (59).

A glândula pineal tem grande importância na imposição dos ritmos biológicos, uma vez que promove a síntese e liberação de melatonina após estimulação simpática. Um estudo comparou a dinâmica da melatonina em animais com diferentes cronotipos e concluiu não haver diferenças no perfil de produção e liberação (61), o que concorda com os achados de atuação semelhante das estruturas centrais de controle.



Figura 5. Imagem representativa do sistema de controle circadiano. Após estímulo de luz captado pela retina, o sinal fótico é conduzido ao núcleo supraquiasmático (SQN) via trato retinohipotalâmico (TRH). É iniciado um loop de feedback negativo no SQN, em que as proteínas *Bmal1* e *Clock* se ligam e induzem a tradução de proteínas responsáveis pelo controle de diferentes variáveis circadianas. Ainda, o complexo *Bmal1/Clock* promove a transcrição-tradução das proteínas *Period* (PER) e *Cryptochrome* (Cry) após ausência do sinal fótico, que por sua vez se ligam e inibem o complexo *Bmal1/clock*, finalizando o ciclo circadiano, que será reiniciado após novo sinal de luz. Imagem adaptada de Nakao, Nakamura e Shibata, 2015 e Durrington *et al.*, 2013)

O fator ambiental modulador (*Zeitgeber*) mais evidente é a variação dia/noite, em que é possível observar clara sincronização com variáveis circadianas fisiológicas e comportamentais (62, 63). O ciclo dia/noite é acompanhado por alteração da temperatura ambiental, sendo que relatos indicam que a exposição à baixas temperaturas aumentam a amplitude do ritmo circadiano da temperatura central em várias espécies, sendo observado também menor valor de acrofase, ou seja, de pico (63). No entanto, a origem dos ritmos circadianos é endógena, sendo que a sincronização dos ritmos às variações geofísicas ambientais funciona apenas como agente modulador (62, 64, 65), fato confirmado por estudos que apontam manutenção dos ritmos biológicos mesmo na ausência de variação ambiental (66, 67).

Além da sincronização externa, os diversos ritmos biológicos apresentam sincronização interna, controlada pela integração entre os relógios biológicos centrais e periféricos (Fig.4) (52). Por exemplo, estudos- em diferentes espécies- apontam para associação entre os ritmos da temperatura corporal e da atividade locomotora (65, 68-70). Ainda, evidências apontam para direta e bidirecional associação entre os ritmos da temperatura corporal e do metabolismo. Alterações na temperatura corporal podem afetar a velocidade das reações químicas do corpo, assim como as alterações metabólicas influenciam diretamente na produção de calor, uma vez que este é subproduto destas reações (71). É importante ressaltar a diferença entre os termos sincronização e geração, ou seja, existe evidente associação entre os ritmos, no entanto, eles são gerados e controlados de forma independente (71). Um grupo de pesquisa europeu buscou entender a interdependência dos ritmos da temperatura central e da atividade locomotora em humanos, para isto, mantiveram a amostra em repouso constante por 5 semanas (72). Como resultado da ausência de atividade locomotora os pesquisadores observaram redução da amplitude do ritmo circadiano da temperatura central, mas não a extinção do mesmo (72). Em animais, é documentado que mesmo com baixos níveis de atividade locomotora, àqueles de característica noturna apresentam maior temperatura central durante a noite, sendo que em animais de hábitos diurnos, este aumento é observado durante o dia (65). Logo, é possível observar que o ritmo da temperatura central não é produto de outros ritmos biológicos (71).

Dois fatores amplamente abordados neste trabalho tem influência sobre a função circadiana: a hipertensão e o envelhecimento (63, 73-75). A pressão arterial apresenta ritmo com pico observado no período matutino e menor valor no período noturno, durante o repouso (57). Esse padrão é determinado principalmente por variáveis intrínsecas ao organismo como a atividade do sistema nervoso simpático e fatores hormonais como liberação de cortisol, catecolaminas e ação do sistema renina-angiotensina-aldosterona. Entretanto, fatores externos como o estado sono/vigília e a prática de atividade física influenciam no controle homeostático e circadiano da pressão arterial (57). A hipertensão leva ao rompimento do ritmo da pressão arterial, caracterizado pela ausência de redução no período de repouso, o que impõe ao organismo maior exposição ao estresse hemodinâmico de pressão, sendo este danoso para diversos órgãos, como coração e os rins (73, 76).

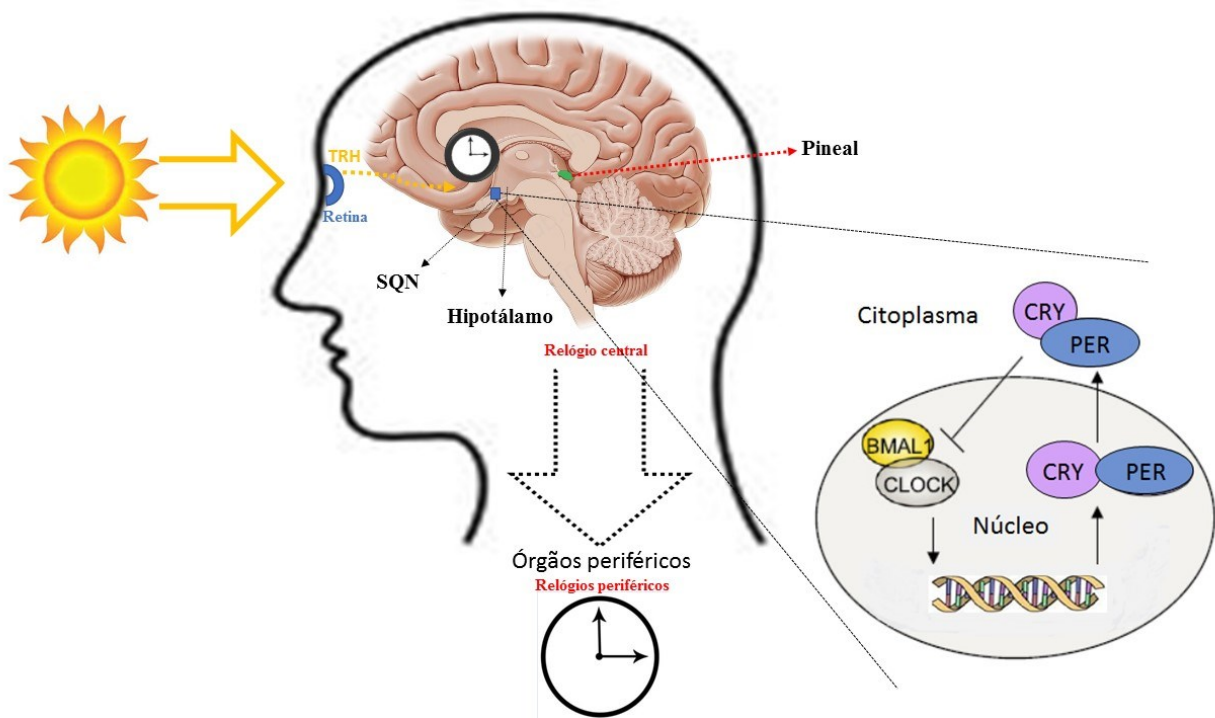
O ritmo circadiano também é afetado pelo envelhecimento (63). Existem alterações clássicas impostas pelo envelhecimento aos ritmos circadianos, por exemplo, a redução da amplitude diária e a perda de sincronização interna entre os diferentes ritmos, bem como desassociação externa aos *zeitgebers* (75, 77). Ainda, alguns trabalhos mostram que o envelhecimento pode promover modificações no período dos ritmos, ou seja, antecipação ou

atraso dos ciclos (78, 79). Em 1922, um grupo demonstrou encurtamento do ritmo circadiano de ratos idosos (80). Evidências apontam para modificação funcional nas estruturas de controle circadiano, apontando que estas apresentam menor responsividade ao estímulo fótico e resposta de oscilação mais ágil e de menor amplitude (81, 82). Pesquisas apontam que esta perda de função do SQN com o avançar da idade é relacionada a uma deterioração neuronal senescente, o que representa processo natural de envelhecimento (83).



Figura 6. Pressão arterial sistólica (PAS) e frequência cardíaca (FC) de ratos normotensos Wistar Kyoto (painel A) e temperatura corporal de ratos normotensos Long-Evans (painel B) durante quatro dias. Imagem adaptada de Lemmer et al. (2003) e Reffinetti (2003).

1.4- Envelhecimento:

O envelhecimento é um processo contínuo e progressivo acompanhado de redução no funcionamento de sistemas e órgãos (84). Sabe-se que o envelhecimento por si promove alterações estruturais semelhantes às ocorridas na HA, como hipertrofia concêntrica do ventrículo esquerdo (85, 86). Ocorre ainda uma degradação natural dos miócitos, acúmulo de fibrose e hemodinâmica coronariana prejudicada (34, 85). No entanto, em combinação com a hipertensão, a gravidade destes distúrbios cardiovasculares é acentuada (85). A prevalência da hipertensão é maior nos idosos, sendo que 52,9% dos indivíduos entre 45 e 64 anos possuem o diagnóstico da doença, aumentando para 78,2% acima de 65 anos (87).

O envelhecimento é acompanhado de reduzida capacidade de combater danos e distúrbios, em função da depressão do sistema imunológico, conhecido como imunosenescência, levando a manutenção de um estado inflamatório crônico (88). Estudos apontam

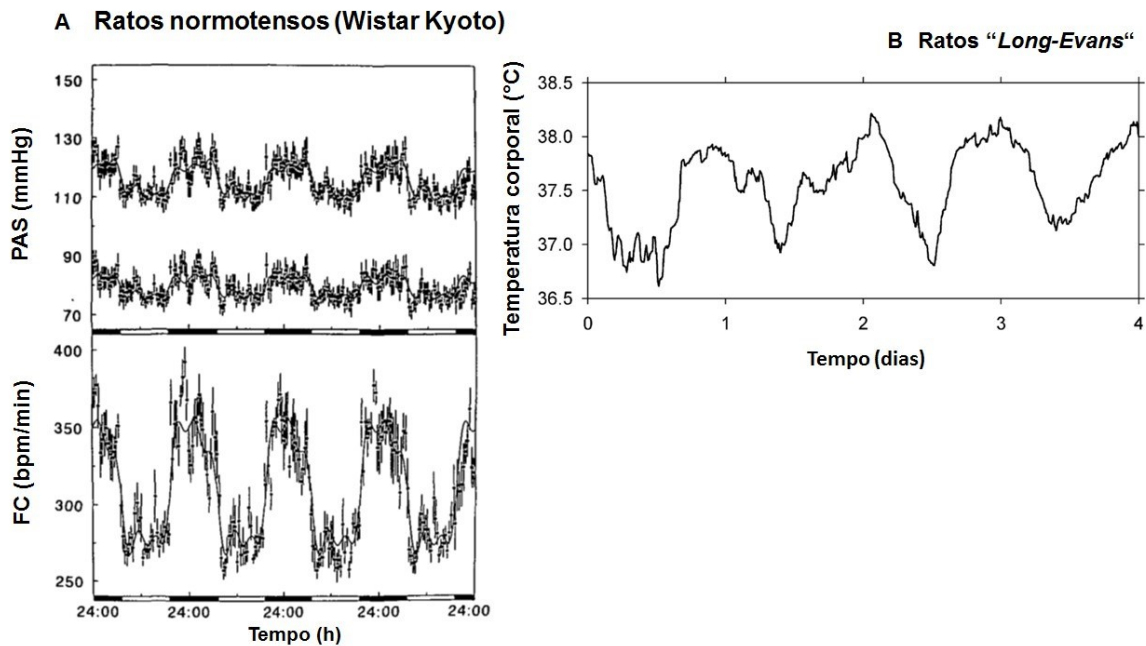
a presença elevada de marcadores pró-inflamatórios no envelhecimento, como a interleucina-6 e o fator de necrose tumoral (89, 90). O quadro inflamatório contínuo danifica as respostas antioxidantes, tendo como consequência o estresse oxidativo (91). Em conjunto, a inflamação e o estresse oxidativo promovem a disfunção endotelial, os radicais livres prejudicam as vias de sinalização para liberação de óxido nítrico no sistema vascular (92, 93). Este tipo de alteração promove um desequilíbrio entre as funções de vasoconstrição e vasodilatação, contribuindo para o aumento da resistência vascular periférica e, conseqüentemente, para a patogênese e manutenção da HA no idoso (18, 94).

1.5- Exercício físico:

Assim como a HA, o exercício físico exerce estímulo para hipertrofia cardíaca, no entanto, esta é classificada como fisiológica (34). O que diferencia o coração hipertenso do treinado não é o tamanho, mas sim a qualidade funcional do tecido (36). Dessa forma, é importante ressaltar que a natureza do estímulo é crucial para determinar o tipo de hipertrofia do miocárdio. O exercício resistido promove sobrecarga de pressão (pós-carga), assim como na hipertensão (95). No entanto, seu estímulo é intervalado, possibilitando ao tecido períodos de recuperação, levando à hipertrofia concêntrica fisiológica, caracterizada pelo aumento das paredes ventriculares com manutenção da cavidade ventricular. Este padrão de hipertrofia promove adição em paralelo de miofibrilas, sendo que a contratilidade e eficiência miocárdica são aprimoradas (95). Já no treinamento aeróbico, caracterizado por impor uma pré-carga ou sobrecarga de volume ao coração, ocorre a adição de sarcômeros em série, caracterizando a hipertrofia excêntrica fisiológica, o que leva ao aumento da cavidade do ventrículo esquerdo aliado à melhora da contratilidade e eficiência do miocárdio (95, 96).

Relatos consistentes apontam que a prática regular de exercício físico é inversamente relacionada ao desenvolvimento da HA (97, 98). Além de atuar como fator de prevenção, o exercício físico é capaz de reduzir a pressão arterial de hipertensos (96, 99-103). Percebem-se respostas hipotensivas imediatamente após a prática, sendo que a magnitude destas é determinada por fatores como o tipo de treinamento, bem como a intensidade e volume aplicados. Sabe-se ainda que estas respostas persistem por aproximadamente 24 horas (104-106). Estudo prévio aponta que uma sessão de exercício aeróbico de baixa intensidade foi capaz de reduzir a pressão arterial sistólica, diastólica e média de idosos (104). Um segundo trabalho apontou que sessões de 10 e 30 min de exercício aeróbico de moderada intensidade foi capaz de reduzir a pressão arterial sistólica e diastólica em aproximadamente 10 mmHg em homens adultos (107). A literatura aponta que o mecanismo responsável pela hipotensão pós-exercício

está ligada a alterações hemodinâmicas promovidas pela prática, entre as quais destacam-se a diminuição da resistência vascular periférica, do volume diastólico final, do volume de ejeção e conseqüentemente do débito cardíaco (104, 105, 108).

Assim como o treinamento aeróbico, o exercício resistido também promove redução da pressão arterial (109-111). Evitava-se recomendar a prática de exercício resistido para indivíduos hipertensos, pois acreditava-se que havia risco de grande elevação da pressão arterial em função de ocorrer a manobra de Valsalva, caracterizada por um esforço expiratório prolongado após o fechamento da glote, induzindo aumento da resistência vascular periférica e conseqüentemente da pressão arterial (112). No entanto, uma série de estudos vem apontando que apesar do aumento momentâneo da pressão arterial provocado pela prática do exercício resistido, após a série, a pressão rapidamente retorna para os valores basais e quando encerrada a sessão de treinamento é observada a hipotensão pós exercício. Estudo prévio encontrou que o treinamento resistido de baixa intensidade levou a redução da pressão arterial de forma aguda, sendo que tal resposta perdurou por aproximadamente 10 horas (109). A literatura aponta ainda que o exercício resistido de moderada e alta intensidade também promovem redução da pressão arterial (110, 111).

O somatório de sessões agudas de exercício físico leva aos efeitos crônicos do treinamento sobre o organismo do indivíduo hipertenso. O resultado de um programa de treinamento sobre a pressão arterial de indivíduos hipertensos é semelhante àqueles observados após uma única sessão de exercício físico (106, 113). Relatos indicam que o treinamento promove reduções mais pronunciadas em indivíduos que apresentam valores maiores de pressão e que a intensidade do treinamento é um fator chave a ser modulado, uma vez que treinamentos mais intensos resultam em maiores reduções da pressão (105, 108).

Além do controle da pressão arterial, o treinamento físico promove benefícios para outros fatores do sistema cardiovascular, como melhora da perfusão miocárdica e periférica, redução do enrijecimento arterial e melhora da função autonômica e endotelial (114). Dessa forma, a prática regular de exercícios físicos funciona como uma estratégia não farmacológica muito importante no combate a HA, bem como a outros distúrbios cardiovasculares, estando presente em todas as orientações de combate à doença (114).

A prática do exercício físico leva a um rompimento momentâneo da homeostase orgânica, indicando uma série de ajustes necessários para manutenção das funções vitais em paralelo a manutenção da atividade realizada (70). Do ponto de vista termorregulatório, é observado um desequilíbrio inicial nas taxas de produção e perda de calor, induzido pela maior

produção de calor dos músculos em atividade e do metabolismo em trabalho aumentado, o que provoca acúmulo de calor corporal (68).

Após as modificações termorregulatórias impostas pelo exercício físico, são iniciados ajustes com objetivo de alcançar um estado de equilíbrio térmico. Para isto, mecanismos de dissipação de calor são ativados, como a vasodilatação- que provoca redirecionamento de fluxo sanguíneo central para periferia- e a sudorese, que por sua vez, possibilita a perda de calor para o ambiente por meio da evaporação do suor (69). No entanto, os roedores apresentam processo de sudorese nulo, sendo que em situação de exercício a vasodilatação da cauda será o principal mecanismo para dissipação de calor (120).

A resposta termorregulatória será dependente do tipo de estímulo aplicado pelo exercício físico, sendo que protocolos progressivos impõem estímulos intercalados em espaços curtos de tempo, impossibilitando a obtenção de um estado estável das variáveis fisiológicas durante a prática. Em contraponto, protocolos com intensidade fixa estabelecem um desafio inicial, no entanto, permite que o organismo se reajuste e estabeleça um estado estável até o fim da prática (115). Esta segunda proposta indica a presença de duas fases distintas de controle termorregulatório durante o exercício físico: as fases dinâmica e estável. A fase dinâmica é caracterizada pelo aumento acentuado da atividade metabólica com objetivo de manutenção do suprimento energético, o que eleva o acúmulo de calor. Além disso, é observado um processo de vasoconstrição com objetivo de redirecionamento de fluxo para musculatura em atividade. A fase dinâmica acontece nos momentos iniciais do exercício físico, com poucos minutos de duração. Na sequência, o acúmulo de calor leva ao atingimento do limiar térmico para vasodilatação, o que promove redirecionamento do fluxo sanguíneo para periferia com objetivo de dissipar calor e conseqüentemente promover a instalação de um estado estável do ponto de vista termorregulatório durante a prática do exercício.

1.6- O paradigma experimental:

A ciência representa um conjunto de conhecimentos a serem estudados, testados, discutidos, replicados e divulgados. Deve ser objetiva, produzindo informações testadas e comprovadas a partir de métodos experimentais rigorosamente planejados e executados. Trata-se de um percurso inacabado, pois a partir do conhecimento já estabelecido novas teorias se formam almejando a evolução e o acréscimo de informação (143).

Objetivando promover o avanço científico, animais comumente são utilizados como modelos experimentais em todos os campos da pesquisa (144). Para isto, normas metodológicas e éticas foram estabelecidas a fim de conservar a qualidade científica, bem como o bem estar

das espécies utilizadas (145). Desta forma, tais modelos precisam atuar como uma representação real do fenômeno a ser estudado. Assim, a seleção do modelo experimental representa passo de extrema importância no planejamento científico, uma vez que o uso do modelo adequado aos objetivos do estudo é crucial para obtenção de resultados confiáveis (145).

Para o estudo da HA essencial o Rato Espontaneamente Hipertenso (*Spontaneously Hypertensive Rat*- SHR) representa um modelo amplamente utilizado. No século passado, existia grande necessidade de criação de um modelo experimental que permitisse o estudo da HA primária ou essencial, portanto, a partir da década de 1950 vários grupos direcionaram seus esforços para este tópico (23, 146, 147). Em 1954, Alexander e col. desenvolveram uma linhagem de coelhos hipertensos, em que até 86% dos machos e 53% das fêmeas manifestaram a doença (147). Em 1958 em Otago, Smirk e Hall desenvolveram uma linhagem de ratos hipertensos a partir do acasalamento entre irmãos, no entanto, apenas 30% dos animais desenvolveram a doença (146). Em 1962, o mesmo grupo relatou que 50% manifestaram a HA, sendo que a média da pressão arterial sistólica obtida foi 147,2 mmHg (148). É importante ressaltar que para roedores a HA é classificada como pressão arterial sistólica (PAS) sustentada acima de 150 mmHg (23, 148-150).

Em 1963 Okamoto e Aoki desenvolveram os SHR a partir dos Wistar Kyoto (WKY), ratos normotensos provenientes de Kyoto, no Japão (23). Os pesquisadores realizaram uma triagem entre os WKY, selecionando aqueles que apresentaram pressão arterial elevada sustentada por aproximadamente um mês, os submetendo ao acasalamento consanguíneo por diversas gerações, até que a partir da 6ª geração todos os descendentes (100%) apresentaram o desenvolvimento da HA (PAS > 150 mmHg) (23, 151). A partir desse momento, os SHR estabeleceram-se como o modelo correspondente ao estudo da HA essencial, utilizando os WKY como controles normotensos (152). Contudo, uma série de pesquisas apontaram limitações no uso dos WKY como controle dos SHR, indicando que estes podem apresentar características inerentes a doença, como elevada PAS, hiperatividade simpática e hipertrofia concêntrica patológica do ventrículo esquerdo (151, 153-156). Desta maneira, os WIS surgiram como uma alternativa de controle para os SHR, uma vez que não apresentam tais características. No entanto, este representa um tópico de amplo debate na literatura.

Todo trabalho experimental exige a presença de um grupo controle, possibilitando a adequada interpretação dos resultados (145, 152). Dessa forma, a seleção do grupo controle representa etapa tão importante quanto a seleção do grupo experimental. Assim, diferentes grupos de pesquisa vêm ao longo do tempo demonstrando preocupação em relação a linhagem

experimental a ser utilizada como controle do SHR, dessa forma, múltiplos estudos realizaram a comparação de variáveis distintas entre SHR, WIS e WKY a fim de fornecer aos diferentes grupos de pesquisa informações no momento da seleção das linhagens (157-169). Ainda assim, este é um tópico que segue gerando debate e divergências na literatura atual, o que gera necessidade de pesquisas direcionadas para melhor elucidar a questão e, conseqüentemente, fornecer maior segurança aos pesquisadores no momento de planejamento e execução dos estudos.

2- Objetivos:

2.1- Geral:

Avaliar os efeitos da hipertensão e do envelhecimento sobre a termorregulação basal e durante o exercício físico de Ratos Espontaneamente Hipertensos e seus principais controles experimentais, Wistar e Wistar Kyoto.

2.2- Específicos:

Caracterizar e comparar o crescimento físico.

Caracterizar e comparar a pressão arterial.

Caracterizar e comparar a função e morfologia do tecido cardíaco.

Caracterizar e comparar o ritmo circadiano da T_{central} .

Caracterizar e comparar o desempenho físico e as respostas termorregulatórias durante o exercício agudo em esteira.

Caracterizar e comparar os efeitos do processo de envelhecimento.

Realizar análise comparativa entre as linhagens utilizadas como controle do SHR.

Realizar ampla caracterização das linhagens estudadas objetivando oferecer ferramentas para seleção dos modelos experimentais em pesquisas futuras.

3- Referências:

1. Blacher J, Levy BI, Mourad JJ, Safar ME, Bakris G. From epidemiological transition to modern cardiovascular epidemiology: hypertension in the 21st century. *Lancet*. 2016 Jul 30;388(10043):530-2.

2. Omran AR. The epidemiologic transition. A theory of the epidemiology of population change. *Milbank Mem Fund Q.* 1971 Oct;49(4):509-38.
3. Smallman-Raynor M, Phillips D. Late stages of epidemiological transition: health status in the developed world. *Health Place.* 1999 Sep;5(3):209-22.
4. Carolina Martinez S, Gustavo Leal F. Epidemiological transition: model or illusion? A look at the problem of health in Mexico. *Soc Sci Med.* 2003 Aug;57(3):539-50.
5. Mensah GA, Roth GA, Sampson UK, Moran AE, Feigin VL, Forouzanfar MH, et al. Mortality from cardiovascular diseases in sub-Saharan Africa, 1990-2013: a systematic analysis of data from the Global Burden of Disease Study 2013. *Cardiovasc J Afr.* 2015 Mar-Apr;26(2 Suppl 1):S6-10.
6. Townsend N, Nichols M, Scarborough P, Rayner M. Cardiovascular disease in Europe--epidemiological update 2015. *Eur Heart J.* 2015 Oct 21;36(40):2696-705.
7. Chen WW, Gao RL, Liu LS, Zhu ML, Wang W, Wang YJ, et al. China cardiovascular diseases report 2015: a summary. *J Geriatr Cardiol.* 2017 Jan;14(1):1-10.
8. Sidney S, Quesenberry CP, Jr., Jaffe MG, Sorel M, Nguyen-Huynh MN, Kushi LH, et al. Recent Trends in Cardiovascular Mortality in the United States and Public Health Goals. *JAMA Cardiol.* 2016 Aug 1;1(5):594-9.
9. Roth GA, Huffman MD, Moran AE, Feigin V, Mensah GA, Naghavi M, et al. Global and regional patterns in cardiovascular mortality from 1990 to 2013. *Circulation.* 2015 Oct 27;132(17):1667-78.
10. Global, regional, and national age-sex specific all-cause and cause-specific mortality for 240 causes of death, 1990-2013: a systematic analysis for the Global Burden of Disease Study 2013. *Lancet.* 2015 Jan 10;385(9963):117-71.
11. Sarki AM, Nduka CU, Stranges S, Kandala NB, Uthman OA. Prevalence of Hypertension in Low- and Middle-Income Countries: A Systematic Review and Meta-Analysis. *Medicine (Baltimore).* 2015 Dec;94(50):e1959.
12. Andrade SSA, Stopa SR, Brito AS, Chueri PS, Szwarcwald CL, Malta DC. Prevalência de hipertensão arterial autorreferida na população brasileira: análise da Pesquisa Nacional de Saúde, 2013. *Epidemiologia e Serviços de Saúde.* 2015;24(2):297-304.
13. Picon RV, Fuchs FD, Moreira LB, Riegel G, Fuchs SC. Trends in prevalence of hypertension in Brazil: a systematic review with meta-analysis. *Plos One.* 2012;7(10):e48255.
14. Guimaraes AC. Hypertension in Brazil. *J Hum Hypertens.* 2002 Mar;16 Suppl 1:S7-S10.
15. Olmos RD, Lotufo PA. Epidemiologia da hipertensão arterial no Brasil e no mundo. *Revista Brasileira de Hipertensão.* 2002;9:21-3.
16. Neder MM, Borges AAN. Hipertensão arterial sistêmica no Brasil: o que avançamos no conhecimento de sua epidemiologia? *Revista Brasileira de Hipertensão.* 2006;13(2):126-33.
17. Carey RM, Whelton PK. Prevention, Detection, Evaluation, and Management of High Blood Pressure in Adults: Synopsis of the 2017 American College of Cardiology/American Heart Association Hypertension Guideline. *Ann Intern Med.* 2018 Mar 6;168(5):351-8.
18. Norlander AE, Madhur MS, Harrison DG. The immunology of hypertension. *J Exp Med.* 2018 Jan 2;215(1):21-33.
19. Cifu AS, Davis AM. Prevention, Detection, Evaluation, and Management of High Blood Pressure in Adults. *JAMA.* 2017 Dec 5;318(21):2132-4.
20. Mulvany MJ. Small artery remodeling and significance in the development of hypertension. *News Physiol Sci.* 2002 Jun;17:105-9.
21. Beevers G, Lip GY, O'Brien E. ABC of hypertension: The pathophysiology of hypertension. *BMJ.* 2001 Apr 14;322(7291):912-6.
22. Sharman JE, Stowasser M. Australian association for exercise and sports science position statement on exercise and hypertension. *J Sci Med Sport.* 2009 Mar;12(2):252-7.
23. Okamoto K, Aoki K. Development of a strain of spontaneously hypertensive rats. *Jpn Circ J.* 1963 Mar;27:282-93.
24. Kaiser SE. Contribuição do estudo da microcirculação à fisiopatologia da hipertensão arterial. *Brazilian Journal of Health and Biomedical sciences.* 2011;10(3):31-8.

25. Renna NF, de Las Heras N, Miatello RM. Pathophysiology of vascular remodeling in hypertension. *Int J Hypertens*. 2013;2013:808353.
26. Sarzani R, Brecher P, Chobanian AV. Growth factor expression in aorta of normotensive and hypertensive rats. *J Clin Invest*. 1989 Apr;83(4):1404-8.
27. Iwatsuki K, Cardinale GJ, Spector S, Udenfriend S. Hypertension: increase of collagen biosynthesis in arteries but not in veins. *Science*. 1977 Oct 28;198(4315):403-5.
28. Sonoyama K, Greenstein A, Price A, Khavandi K, Heagerty T. Vascular remodeling: implications for small artery function and target organ damage. *Therapeutic Advances in Cardiovascular Disease*. 2007;1(2):129-37.
29. Osol G, Osol R, Halpern W. Pre-existing level of tone is an important determinant of cerebral artery autoregulatory responsiveness. *Journal of hypertension*. 1989;7:S67-S9.
30. Izzard AS, Graham D, Burnham MP, Heerkens EH, Dominiczak AF, Heagerty AM. Myogenic and structural properties of cerebral arteries from the stroke-prone spontaneously hypertensive rat. *Am J Physiol Heart Circ Physiol*. 2003 Oct;285(4):H1489-94.
31. Heerkens EH, Izzard AS, Heagerty AM. Integrins, Vascular Remodeling, and Hypertension. *Hypertension*. 2007;49:1-4.
32. Pawlusch DG, Moore RL, Musch TI, Davidson WR, Jr. Echocardiographic evaluation of size, function, and mass of normal and hypertrophied rat ventricles. *J Appl Physiol* (1985). 1993 May;74(5):2598-605.
33. Matsubara LS, Narikawa S, Ferreira AL, Paiva SA, Zornoff LM, Matsubara BB. [Myocardial remodeling in chronic pressure or volume overload in the rat heart]. *Arq Bras Cardiol*. 2006 Feb;86(2):126-30.
34. Richey PA, Brown SP. Pathological versus physiological left ventricular hypertrophy: a review. *J Sports Sci*. 1998 Feb;16(2):129-41.
35. Janicki JS. Myocardial collagen remodeling and left ventricular diastolic function. *Braz J Med Biol Res*. 1992;25(10):975-82.
36. Weber KT, Brilla CG. Pathological hypertrophy and cardiac interstitium. Fibrosis and renin-angiotensin-aldosterone system. *Circulation*. 1991 Jun;83(6):1849-65.
37. Rossi MA. Pathologic fibrosis and connective tissue matrix in left ventricular hypertrophy due to chronic arterial hypertension in humans. *J Hypertens*. 1998 Jul;16(7):1031-41.
38. Querejeta R, Varo N, López B, Larman M, Artiñano E, Etayo JC, et al. Serum carboxy-terminal propeptide of procollagen type I is a marker of myocardial fibrosis in hypertensive heart disease. *Circulation*. 2000;11(10):1729-35.
39. González A, Lopez B, Díez J. Myocardial fibrosis in arterial hypertension. *European Heart Journal Supplements*. 2002:18-22.
40. Bishop JE, Lindahl G. Regulation of cardiovascular collagen synthesis by mechanical load. *Cardiovasc Res*. 1999 Apr;42(1):27-44.
41. Mill JG, Vassallo DV. Hipertrofia cardíaca. *Revista Brasileira de Hipertensão*. 2001;8:63-75.
42. Ohsato K, Shimizu M, Sugihara N, Konishi K, Takeda R. Histopathological factors related to diastolic function in myocardial hypertrophy. *Jpn Circ J*. 1992 Apr;56(4):325-33.
43. Adams MA, Bobik A, Korner PI. Differential development of vascular and cardiac hypertrophy in genetic hypertension. Relation to sympathetic function. *Hypertension*. 1989 Aug;14(2):191-202.
44. Grossman W. Cardiac hypertrophy: useful adaptation or pathologic process? *Am J Med*. 1980 Oct;69(4):576-84.
45. Bristow MR. Mechanisms of development of heart failure in the hypertensive patient. *Cardiology*. 1999;92 Suppl 1:3-6; discussion 7-9, 20-1.
46. Díez J, Fortuño MA, Ravassa S. Apoptosis in hypertensive heart disease. *Hypertension*. 1998;13:317-25.
47. Regula KM, Kirshenbaum LA. Apoptosis of ventricular myocytes: a means to an end. *J Mol Cell Cardiol*. 2005 Jan;38(1):3-13.
48. Gonzalez A, Ravassa S, Lopez B, Loperena I, Querejeta R, Díez J. Apoptosis in hypertensive heart disease: a clinical approach. *Curr Opin Cardiol*. 2006 Jul;21(4):288-94.

49. Freedman MS, Lucas RJ, Soni B, von Schantz M, Munoz M, David-Gray Z, et al. Regulation of mammalian circadian behavior by non-rod, non-cone, ocular photoreceptors. *Science*. 1999 Apr 16;284(5413):502-4.
50. Weinert D. Circadian temperature variation and ageing. *Ageing Res Rev*. 2010 Jan;9(1):51-60.
51. Nakao A, Nakamura Y, Shibata S. The circadian clock functions as a potent regulator of allergic reaction. *Allergy*. 2015 May;70(5):467-73.
52. Dibner C, Schibler U, Albrecht U. The mammalian circadian timing system: organization and coordination of central and peripheral clocks. *Annu Rev Physiol*. 2010;72:517-49.
53. Balsalobre A. Clock genes in mammalian peripheral tissues. *Cell Tissue Res*. 2002 Jul;309(1):193-9.
54. Ukai H, Ueda HR. Systems biology of mammalian circadian clocks. *Annu Rev Physiol*. 2010;72:579-603.
55. Smale L, Lee T, Nunez AA. Mammalian diurnality: some facts and gaps. *J Biol Rhythms*. 2003 Oct;18(5):356-66.
56. Dardente H, Klosen P, Caldelas I, Pevet P, Masson-Pevet M. Phenotype of Per1- and Per2-expressing neurons in the suprachiasmatic nucleus of a diurnal rodent (*Arvicanthis ansorgei*): comparison with a nocturnal species, the rat. *Cell Tissue Res*. 2002 Oct;310(1):85-92.
57. Takeda N, Maemura K. Circadian clock and cardiovascular disease. *J Cardiol*. 2011 May;57(3):249-56.
58. Refinetti R, Menaker M. The circadian rhythm of body temperature. *Physiol Behav*. 1992 Mar;51(3):613-37.
59. Vosko AM, Hagenauer MH, Hummer DL, Lee TM. Period gene expression in the diurnal degu (*Octodon degus*) differs from the nocturnal laboratory rat (*Rattus norvegicus*). *Am J Physiol Regul Integr Comp Physiol*. 2009 Feb;296(2):R353-61.
60. Schwartz WJ, Reppert SM, Eagan SM, Moore-Ede MC. In vivo metabolic activity of the suprachiasmatic nuclei: a comparative study. *Brain Res*. 1983 Sep 5;274(1):184-7.
61. Garidou ML, Gauer F, Vivien-Roels B, Sicard B, Pevet P, Simonneaux V. Pineal arylalkylamine N-acetyltransferase gene expression is highly stimulated at night in the diurnal rodent, *Arvicanthis ansorgei*. *Eur J Neurosci*. 2002 May;15(10):1632-40.
62. Johnson CH, Elliott JA, Foster R. Entrainment of circadian programs. *Chronobiol Int*. 2003 Sep;20(5):741-74.
63. Refinetti R. The circadian rhythm of body temperature. *Front Biosci (Landmark Ed)*. 2010 Jan 1;15:564-94.
64. Mendoza J. Circadian clocks: setting time by food. *J Neuroendocrinol*. 2007 Feb;19(2):127-37.
65. Refinetti R. Relationship between the daily rhythms of locomotor activity and body temperature in eight mammalian species. *Am J Physiol*. 1999 Nov;277(5):R1493-500.
66. van Jaarsveld B, Bennett NC, Hart DW, Oosthuizen MK. Locomotor activity and body temperature rhythms in the Mahali mole-rat (*C. h. mahali*): The effect of light and ambient temperature variations. *J Therm Biol*. 2019 Jan;79:24-32.
67. Honma KI, Hiroshige T. Internal synchronization among several circadian rhythms in rats under constant light. *Am J Physiol*. 1978 Nov;235(5):R243-9.
68. Saltin B, Gagge AP, Stolwijk JA. Body temperatures and sweating during thermal transients caused by exercise. *J Appl Physiol*. 1970 Mar;28(3):318-27.
69. Webb P. Daily activity and body temperature. *Eur J Appl Physiol Occup Physiol*. 1993;66(2):174-7.
70. Arnold J, LeBlanc J, Cote J, Lalonde J, Richard D. Exercise suppression of thermoregulatory thermogenesis in warm- and cold-acclimated rats. *Can J Physiol Pharmacol*. 1986 Jul;64(7):922-6.
71. Refinetti R. Circadian rhythmicity of body temperature and metabolism. *Temperature*. 2020.
72. Golja P, Eiken O, Rodman S, Sirok B, Mekjavic IB. Core temperature circadian rhythm during 35 days of horizontal bed rest. *J Gravit Physiol*. 2002 Jul;9(1):P187-8.
73. Uzu T, Kimura G. Diuretics shift circadian rhythm of blood pressure from nondipper to dipper in essential hypertension. *Circulation*. 1999 Oct 12;100(15):1635-8.

74. Pickering TG. The clinical significance of diurnal blood pressure variations. Dippers and nondippers. *Circulation*. 1990 Feb;81(2):700-2.
75. Hofman MA. The human circadian clock and aging. *Chronobiol Int*. 2000 May;17(3):245-59.
76. Uzu T, Kazembe FS, Ishikawa K, Nakamura S, Inenaga T, Kimura G. High sodium sensitivity implicates nocturnal hypertension in essential hypertension. *Hypertension*. 1996 Jul;28(1):139-42.
77. Mistlberger RE, Houtp TA, Moore-Ede MC. Effects of aging on food-entrained circadian rhythms in the rat. *Neurobiol Aging*. 1990 Nov-Dec;11(6):619-24.
78. Li H, Satinoff E. Changes in circadian rhythms of body temperature and sleep in old rats. *Am J Physiol*. 1995 Jul;269(1 Pt 2):R208-14.
79. Weinert D, Waterhouse J. Daily activity and body temperature rhythms do not change simultaneously with age in laboratory mice. *Physiol Behav*. 1999 Jun;66(4):605-12.
80. Witting W, Mirmiran M, Bos NP, Swaab DF. The effect of old age on the free-running period of circadian rhythms in rat. *Chronobiol Int*. 1994 Apr;11(2):103-12.
81. Satinoff E, Li H, Tchong TK, Liu C, McArthur AJ, Medanic M, et al. Do the suprachiasmatic nuclei oscillate in old rats as they do in young ones? *Am J Physiol*. 1993 Nov;265(5 Pt 2):R1216-22.
82. Sutin EL, Dement WC, Heller HC, Kilduff TS. Light-induced gene expression in the suprachiasmatic nucleus of young and aging rats. *Neurobiol Aging*. 1993 Sep-Oct;14(5):441-6.
83. Hofman MA, Swaab DF. Influence of aging on the seasonal rhythm of the vasopressin-expressing neurons in the human suprachiasmatic nucleus. *Neurobiol Aging*. 1995 Nov-Dec;16(6):965-71.
84. Franceschi C, Motta L, Motta M, Malaguarnera M, Capri M, Vasto S, et al. The extreme longevity: the state of the art in Italy. *Exp Gerontol*. 2008 Feb;43(2):45-52.
85. Susic D, Nunez E, Hosoya K, Frohlich ED. Coronary hemodynamics in aging spontaneously hypertensive and normotensive Wistar-Kyoto rats. *J Hypertens*. 1998 Feb;16(2):231-7.
86. Olivetti G, Melissari M, Capasso JM, Anversa P. Cardiomyopathy of the aging human heart. Myocyte loss and reactive cellular hypertrophy. *Circ Res*. 1991 Jun;68(6):1560-8.
87. Benjamin EJ, Muntner P, Alonso A, Bittencourt MS, Callaway CW, Carson AP, et al. Heart Disease and Stroke Statistics-2019 Update: A Report From the American Heart Association. *Circulation*. 2019 Mar 5;139(10):e56-e528.
88. Chung HY, Cesari M, Anton S, Marzetti E, Giovannini S, Seo AY, et al. Molecular inflammation: underpinnings of aging and age-related diseases. *Ageing Res Rev*. 2009 Jan;8(1):18-30.
89. Singh T, Newman AB. Inflammatory markers in population studies of aging. *Ageing Res Rev*. 2011 Jul;10(3):319-29.
90. Ershler WB, Sun WH, Binkley N, Gravenstein S, Volk MJ, Kamoske G, et al. Interleukin-6 and aging: blood levels and mononuclear cell production increase with advancing age and in vitro production is modifiable by dietary restriction. *Lymphokine Cytokine Res*. 1993 Aug;12(4):225-30.
91. Pinzani P, Petrucci E, Orlando C, Stefanescu A, Antonini MF, Serio M, et al. Reduced serum antioxidant capacity in healthy centenarians. *Clin Chem*. 1997 May;43(5):855-6.
92. Rubio-Ruiz ME, Perez-Torres I, Soto ME, Pastelin G, Guarner-Lans V. Aging in blood vessels. Medicinal agents FOR systemic arterial hypertension in the elderly. *Ageing Res Rev*. 2014 Nov;18:132-47.
93. Park S, Lakatta EG. Role of inflammation in the pathogenesis of arterial stiffness. *Yonsei Med J*. 2012 Mar;53(2):258-61.
94. Chrissobolis S, Miller AA, Drummond GR, Kemp-Harper BK, Sobey CG. Oxidative stress and endothelial dysfunction in cerebrovascular disease. *Front Biosci (Landmark Ed)*. 2011 Jan 1;16:1733-45.
95. Fernandes T, Soci UP, Oliveira EM. Eccentric and concentric cardiac hypertrophy induced by exercise training: microRNAs and molecular determinants. *Braz J Med Biol Res*. 2011 Sep;44(9):836-47.
96. Tanaka H, Bassett DR, Jr., Howley ET, Thompson DL, Ashraf M, Rawson FL. Swimming training lowers the resting blood pressure in individuals with hypertension. *J Hypertens*. 1997 Jun;15(6):651-7.

97. Barlow CE, LaMonte MJ, Fitzgerald SJ, Kampert JB, Perrin JL, Blair SN. Cardiorespiratory fitness is an independent predictor of hypertension incidence among initially normotensive healthy women. *Am J Epidemiol*. 2006 Jan 15;163(2):142-50.
98. Banda JA, Clouston K, Sui X, Hooker SP, Lee CD, Blair SN. Protective health factors and incident hypertension in men. *Am J Hypertens*. 2010 Jun;23(6):599-605.
99. Hagberg JM, Montain SJ, Martin WH, 3rd, Ehsani AA. Effect of exercise training in 60- to 69-year-old persons with essential hypertension. *Am J Cardiol*. 1989 Aug 1;64(5):348-53.
100. Suter E, Marti B, Tschopp A, Wanner HU, Wenk C, Gutzwiller F. Effects of self-monitored jogging on physical fitness, blood pressure and serum lipids: a controlled study in sedentary middle-aged men. *Int J Sports Med*. 1990 Dec;11(6):425-32.
101. Blumenthal JA, Sherwood A, Gullette EC, Babyak M, Waugh R, Georgiades A, et al. Exercise and weight loss reduce blood pressure in men and women with mild hypertension: effects on cardiovascular, metabolic, and hemodynamic functioning. *Arch Intern Med*. 2000 Jul 10;160(13):1947-58.
102. Staffileno BA, Braun LT, Rosenson RS. The accumulative effects of physical activity in hypertensive post-menopausal women. *J Cardiovasc Risk*. 2001 Oct;8(5):283-90.
103. Miyai N, Arita M, Miyashita K, Morioka I, Shiraishi T, Nishio I, et al. Antihypertensive effects of aerobic exercise in middle-aged normotensive men with exaggerated blood pressure response to exercise. *Hypertens Res*. 2002 Jul;25(4):507-14.
104. Brandao Rondon MU, Alves MJ, Braga AM, Teixeira OT, Barretto AC, Krieger EM, et al. Postexercise blood pressure reduction in elderly hypertensive patients. *J Am Coll Cardiol*. 2002 Feb 20;39(4):676-82.
105. Overton JM, Joyner MJ, Tipton CM. Reductions in blood pressure after acute exercise by hypertensive rats. *J Appl Physiol* (1985). 1988 Feb;64(2):748-52.
106. Cornelissen VA, Fagard RH. Effects of endurance training on blood pressure, blood pressure-regulating mechanisms, and cardiovascular risk factors. *Hypertension*. 2005 Oct;46(4):667-75.
107. MacDonald JR, MacDougall JD, Hogben CD. The effects of exercise duration on post-exercise hypotension. *J Hum Hypertens*. 2000 Feb;14(2):125-9.
108. Carpio-Rivera E, Moncada-Jimenez J, Salazar-Rojas W, Solera-Herrera A. Acute Effects of Exercise on Blood Pressure: A Meta-Analytic Investigation. *Arq Bras Cardiol*. 2016 May;106(5):422-33.
109. Melo CM, Alencar Filho AC, Tinucci T, Mion D, Jr., Forjaz CL. Postexercise hypotension induced by low-intensity resistance exercise in hypertensive women receiving captopril. *Blood Press Monit*. 2006 Aug;11(4):183-9.
110. Brito Ade F, de Oliveira CV, Santos Mdo S, Santos Ada C. High-intensity exercise promotes postexercise hypotension greater than moderate intensity in elderly hypertensive individuals. *Clin Physiol Funct Imaging*. 2014 Mar;34(2):126-32.
111. Moraes MR, Bacurau RF, Simoes HG, Campbell CS, Pudo MA, Wasinski F, et al. Effect of 12 weeks of resistance exercise on post-exercise hypotension in stage 1 hypertensive individuals. *J Hum Hypertens*. 2012 Sep;26(9):533-9.
112. Porth CJ, Bamrah VS, Tristani FE, Smith JJ. The Valsalva maneuver: mechanisms and clinical implications. *Heart Lung*. 1984 Sep;13(5):507-18.
113. Kelley GA, Sharpe Kelley K. Aerobic exercise and resting blood pressure in older adults: a meta-analytic review of randomized controlled trials. *J Gerontol A Biol Sci Med Sci*. 2001 May;56(5):M298-303.
114. Fiuzza-Luces C, Garatachea N, Berger NA, Lucia A. Exercise is the real polypill. *Physiology* (Bethesda). 2013 Sep;28(5):330-58.
115. Gordon CJ. Temperature regulation in laboratory rodents.: United Kingdom; 1993.
116. Blatteis CM. Physiology and pathophysiology of temperature regulation. World Scientific Publishing.1998.
117. Ivanov KP. The development of the concepts of homeothermy and thermoregulation. *Journal of Thermal Biology*. 2006;31:24-9.

118. Romanovsky AA. Thermoregulation: some concepts have changed. Functional architecture of the thermoregulatory system. *Am J Physiol Regul Integr Comp Physiol*. 2007 Jan;292(1):R37-46.
119. Terrien J, Perret M, Aujard F. Behavioral thermoregulation in mammals: a review. *Front Biosci (Landmark Ed)*. 2011 Jan 1;16:1428-44.
120. Morrison SF, Nakamura K. Central neural pathways for thermoregulation. *Front Biosci (Landmark Ed)*. 2011 Jan 1;16:74-104.
121. Romanovsky AA, Ivanov AI, Shimansky YP. Molecular biology of thermoregulation - Selected contribution: Ambient temperature for experiments in rats: a new method for determining the zone of thermal neutrality. *Journal of Applied Physiology*. 2002 Jun;92(6):2667-79.
122. Nakamura K. Central circuitries for body temperature regulation and fever. *Am J Physiol Regul Integr Comp Physiol*. 2011 Nov;301(5):R1207-28.
123. Tansey EA, Johnson CD. Recent advances in thermoregulation. *Adv Physiol Educ*. 2015 Sep;39(3):139-48.
124. Morrison SF. Central neural control of thermoregulation and brown adipose tissue. *Auton Neurosci*. 2016 Apr;196:14-24.
125. Boulant JA. Neuronal basis of Hammel's model for set-point thermoregulation. *J Appl Physiol (1985)*. 2006 Apr;100(4):1347-54.
126. Boulant JA, Dean JB. Temperature receptors in the central nervous system. *Annu Rev Physiol*. 1986;48:639-54.
127. Benarroch EE. Thermoregulation: recent concepts and remaining questions. *Neurology*. 2007 Sep 18;69(12):1293-7.
128. Takashima Y, Daniels RL, Knowlton W, Teng J, Liman ER, McKemy DD. Diversity in the neural circuitry of cold sensing revealed by genetic axonal labeling of transient receptor potential melastatin 8 neurons. *J Neurosci*. 2007 Dec 19;27(51):14147-57.
129. Campero M, Baumann TK, Bostock H, Ochoa JL. Human cutaneous C fibres activated by cooling, heating and menthol. *J Physiol*. 2009 Dec 1;587(Pt 23):5633-52.
130. Duclaux R, Kenshalo DR, Sr. Response characteristics of cutaneous warm receptors in the monkey. *J Neurophysiol*. 1980 Jan;43(1):1-15.
131. Hensel H, Iggo A. Analysis of cutaneous warm and cold fibres in primates. *Pflugers Arch*. 1971;329(1):1-8.
132. Madden CJ, Morrison SF. Central nervous system circuits that control body temperature. *Neurosci Lett*. 2019 Mar 23;696:225-32.
133. Morris NB, Filingeri D, Halaki M, Jay O. Evidence of viscerally-mediated cold-defence thermoeffector responses in man. *J Physiol*. 2017 Feb 15;595(4):1201-12.
134. Chen XM, Hosono T, Yoda T, Fukuda U, Kanosue K. Efferent projection from the preoptic area for the control of non-shivering thermogenesis in rats. *J Physiol-London*. 1998 Nov 1;512(3):883-92.
135. Conceicao EPS, Madden CJ, Morrison SF. Neurons in the rat ventral lateral preoptic area are essential for the warm-evoked inhibition of brown adipose tissue and shivering thermogenesis. *Acta Physiol (Oxf)*. 2019 Apr;225(4):e13213.
136. Nakamura K, Morrison SF. Preoptic mechanism for cold-defensive responses to skin cooling. *J Physiol*. 2008 May 15;586(10):2611-20.
137. Tanaka M, Nagashima K, McAllen RM, Kanosue K. Role of the medullary raphe in thermoregulatory vasomotor control in rats. *J Physiol*. 2002 Apr 15;540(Pt 2):657-64.
138. Tanaka M, McKinley MJ, McAllen RM. Roles of two preoptic cell groups in tonic and febrile control of rat tail sympathetic fibers. *Am J Physiol Regul Integr Comp Physiol*. 2009 Apr;296(4):R1248-57.
139. Refinetti R. Homeostasis and circadian rhythmicity in the control of body temperature. *Ann N Y Acad Sci*. 1997 Mar 15;813:63-70.
140. Myers BL, Badia P. Changes in circadian rhythms and sleep quality with aging: mechanisms and interventions. *Neurosci Biobehav Rev*. 1995 Winter;19(4):553-71.
141. Gonzalez-Alonso J. Human thermoregulation and the cardiovascular system. *Experimental Physiology*. 2012 Mar;97(3):340-6.

142. O'Leary DS, Wang G. Impaired thermoregulatory cutaneous vasodilation in spontaneously hypertensive rats. *J Appl Physiol* (1985). 1994 Aug;77(2):692-6.
143. Borko H. *Information Science: What Is It? American Documentation*. 1968:3-5.
144. Ferreira LM, Hochman B, Barbosa MVJ. Modelos experimentais em pesquisa. *Acta Cirúrgica Brasileira*. 2005;20(2):28-34.
145. Fagundes DJ, Taha MO. Modelo animal de doença: critérios de escolha e espécies de animais de uso corrente. *Acta Cirúrgica Brasileira*. 2004;19(1):59-65.
146. Smirk FH, Hall WH. Inherited hypertension in rats. *Nature*. 1958 Sep 13;182(4637):727-8.
147. Alexander N, Hinshaw LB, Drury DR. Development of a strain of spontaneously hypertensive rabbits. *Proc Soc Exp Biol Med*. 1954 Aug-Sep;86(4):855-8.
148. Phelan EL, Smirk FH. Cardiac hypertrophy in genetically hypertensive rats. *The Journal of Pathology and Bacteriology*. 1962;80:445-8.
149. Page IH. A Method for Producing Persistent Hypertension by Cellophane. *Science*. 1939 Mar 24;89(2308):273-4.
150. Phelan EL, Eryetishir I, Smirk FH. Observations on the responses of rats with spontaneous hypertension and control rats to pressor drugs and to hexamethonium. *Circ Res*. 1962 May;10:817-24.
151. Okamoto K, Tabei R, Fukushima M, Nosaka S, Yamori Y. Further observations of the development of a strain of spontaneously hypertensive rats. *Jpn Circ J*. 1966 Jun;30(6):703-16.
152. Doggrell SA, Brown L. Rat models of hypertension, cardiac hypertrophy and failure. *Cardiovascular Research*. 1998 Jul;39(1):89-105.
153. Kurtz TW, Montano M, Chan L, Kabra P. Molecular evidence of genetic heterogeneity in Wistar-Kyoto rats: implications for research with the spontaneously hypertensive rat. *Hypertension*. 1989 Feb;13(2):188-92.
154. Kurtz TW, Morris RC, Jr. Biological variability in Wistar-Kyoto rats. Implications for research with the spontaneously hypertensive rat. *Hypertension*. 1987 Jul;10(1):127-31.
155. Deschepper CF, Picard S, Thibault G, Touyz R, Rouleau JL. Characterization of myocardium, isolated cardiomyocytes, and blood pressure in WKHA and WKY rats. *Am J Physiol Heart Circ Physiol*. 2002 Jan;282(1):H149-55.
156. Collins HL, Loka AM, DiCarlo SE. Daily exercise-induced cardioprotection is associated with changes in calcium regulatory proteins in hypertensive rats. *American Journal of Physiology-Heart and Circulatory Physiology*. 2005;288:H532-H40.
157. Eichelman B, Dejong W, Williams RB. Aggressive behavior in hypertensive and normotensive rat strains. *Physiol Behav*. 1973 Feb;10(2):301-4.
158. Lundin S, Herlitz H, Hallback-Nordlander M, Ricksten SE, Gothberg G, Berglund G. Sodium balance during development of hypertension in the spontaneously hypertensive rat (SHR). *Acta Physiol Scand*. 1982 Jul;115(3):317-23.
159. Nishiyama K, Nishiyama A, Frohlich ED. Regional blood flow in normotensive and spontaneously hypertensive rats. *Am J Physiol*. 1976 Mar;230(3):691-8.
160. Herlitz H, Lundin S, Henning M, Aurell M, Karlberg BE, Berglund G. Hormonal pattern during development of hypertension in spontaneously hypertensive rats (SHR). *Clin Exp Hypertens A*. 1982;4(6):915-35.
161. Felten SY, Weyhenmeyer JA, Felten DL. Norepinephrine and serotonin in central autonomic nuclei in the spontaneously hypertensive rat and two normotensive control rats. *Brain Res Bull*. 1984 Sep;13(3):437-41.
162. Hard E, Carlsson SG, Jern S, Larsson K, Lindh AS, Svensson L. Behavioral reactivity in spontaneously hypertensive rats. *Physiol Behav*. 1985 Oct;35(4):487-92.
163. Soderpalm B. The SHR exhibits less "anxiety" but increased sensitivity to the anticonflict effect of clonidine compared to normotensive controls. *Pharmacol Toxicol*. 1989 Nov;65(5):381-6.
164. Sagvolden T, Pettersen MB, Larsen MC. Spontaneously hypertensive rats (SHR) as a putative animal model of childhood hyperkinesis: SHR behavior compared to four other rat strains. *Physiol Behav*. 1993 Dec;54(6):1047-55.

165. Gattone VH, 2nd. Body weight of the spontaneously hypertensive rat during the suckling and weanling periods. *Jpn Heart J.* 1986 Nov;27(6):881-4.
166. Bizot JC, Chenault N, Houze B, Herpin A, David S, Pothion S, et al. Methylphenidate reduces impulsive behaviour in juvenile Wistar rats, but not in adult Wistar, SHR and WKY rats. *Psychopharmacology (Berl).* 2007 Aug;193(2):215-23.
167. Langen B, Dost R. Comparison of SHR, WKY and Wistar rats in different behavioural animal models: effect of dopamine D1 and alpha2 agonists. *Atten Defic Hyperact Disord.* 2011 Mar;3(1):1-12.
168. Sanada LS, Tavares MR, Neubern MC, Salgado HC, Fazan VP. Can Wistar rats be used as the normotensive controls for nerve morphometry investigations in spontaneously hypertensive rats (SHR)? *Acta Cir Bras.* 2011 Dec;26(6):514-20.
169. Gordon CJ, Phillips PM, Johnstone AF. Impact of genetic strain on body fat loss, food consumption, metabolism, ventilation, and motor activity in free running female rats. *Physiol Behav.* 2016 Jan 1;153:56-63.

CAPÍTULO 1

Mapping and characterization of experimental models used to Spontaneously Hypertensive Rat control (Wistar and Wistar Kyoto)- a scoping review.

Leonardo Mateus Teixeira de Rezende¹, Leôncio Lopes Soares¹, Antônio José Natali¹, Cândido Celso Coimbra², Thales Nicolau Prímola Gomes¹.

- 1- Exercise Biology Laboratory, Department of Physical Education, Federal University of Viçosa, Viçosa, MG, Brazil
 2- Laboratory of Endocrinology and Metabolism, Department of Physiology and Biophysics, Federal University of Minas Gerais, Belo Horizonte, MG, Brazil.

Abstract:

Introduction: The Spontaneously Hypertensive Rat (SHR) is an experimental model widely used for the study of essential arterial hypertension. However, there is a literature impasse regarding the designation of the best model to be used as SHR experimental control, with the Wistar Kyoto rats (WKY) and Wistar rats (WIS) being the most used. **Objective:** this work aimed to map studies that used the WIS and WKY strains simultaneously as SHR control, allowing the proper characterization of the available variables of strains. **Methods:** a scoping review based on the Preferred Reporting Items for Systematic Reviews and Meta-analysis (PRISMA-ScR). The following descriptors were defined and used in PubMed, Web of science and Embase data bases: “*Spontaneously hypertensive rat OR SHR AND Wistar Kyoto OR Normotensive Wistar Kyoto Rat OR WKY AND Wistar OR Normotensive Wistar Rat OR WIS OR NWR*“. Two reviewers independently analyzed first the titles and abstract of all studies identified by the searches using *Rayyan*, a Web application designed to assist in this step of the review studies. after this screening, in which the inclusion and exclusion criteria were applied, the papers were read in full. **Results:** After applying the search and selection methods, 161 articles were included for analysis, with 68.4% indicating that both normotensive animals can be used as controls, 13.49% and 6.47% of the studies indicated WIS and WKY as better control, respectively. **Conclusions:** This review confirmed that both normotensive models can be used to control SHR, however, it is necessary that researchers carefully analyze which one to select based on their objectives and on which experiments they will perform.

Keywords: Spontaneously Hypertensive Rats; experimental models; control group.

1- Introduction:

The science consists of a set of knowledge to be studied, tested, discussed, replicated and disseminated. It should be objective, generating tested and proved information from experimental methods carefully planned and executed. It is a continuous pathway, since from the established data, new theories are formed aiming the progress and the information addition (1).

Aiming to promote the scientific advancement, animals are commonly used as experimental models in all research fields (2). For this, methodological and ethical standards

were established in order to preserve the scientific quality, as well as the welfare of the species used (3). Thus, such models need to be a real representation of the phenomenon studied. Consequently, the selection of the experimental model represents an extremely important step in scientific planning, since the use of the appropriate model to the study objectives is crucial to obtain reliable results (3).

For the study of essential arterial hypertension (EAH), the Spontaneously Hypertensive Rat (SHR) represents a widely used model. In the 1950s, hypertension expanded as a high-incidence disease, which made it necessary to develop scientific studies to better understand this phenomenon. However, until now, there was no adequate experimental model for the disease studying. Thus, several research groups pointed their efforts towards this topic (4-6).

In 1954, Alexander *et al.*, developed a strain of hypertensive rabbits, in which 86% of males and 53% of females manifested the disease (6). In 1958 in Otago, Smirk and Hall developed a strain of hypertensive rats from mating between siblings, however, only 30% of the animals developed the disease (4). In 1962, the same group reported that 50% of animals manifested the disease, and the mean systolic blood pressure (SBP) obtained was 147.2 mmHg (7). It is important to note that for rodents, EAH is classified as sustained SBP above 150 mmHg (5, 7-9).

In 1963, Okamoto and Aoki developed the SHR strain from Wistar Kyoto (WKY)- a normotensive rat from Kyoto- Japan (5). The researchers performed a screening among the WKY rats, selecting those had sustained high blood pressure for approximately one month, subjecting them to consanguineous mating for several generations, until after the 6th generation all descendants (100%) presented the development of EAH (SBP > 150 mmHg) (5, 10). Thereafter, the SHR were established as the appropriate model for EAH study, using the normotensive WKY as controls (11). However, several studies have pointed out limitations in the WKY used as SHR control, indicating that strain may have characteristics inherent to the disease, such as high SBP, sympathetic hyperactivity and left ventricle pathological concentric hypertrophy (10, 12-15).

The normotensive Wistar rat-WIS emerged as an alternative control for SHR, since they do not have such characteristics. These animals surged in Philadelphia-USA in the early 20th century, at the Wistar Institute of Anatomy and Biology and reports show that this experimental strain served as basis for the development of many others, such as the WKY (16, 17). In 1938 a group of WIS rats were transported from Philadelphia to University of Tokyo-Japan, followed in 1944 to University Hokkaido. In 1951 they arrived at the Kyoto University Faculty of Medicine, where they were used as progenitor of the WKY and, consequently, of the SHR (18,

19). Thus, there is a genetic relationship between these three strains, with WIS representing the matrix for generating the others (18). Therefore, which strain supposed to be used as SHR control represents a topic of wide debate in the literature.

All experimental work requires the presence of a control group, which allows the suitable interpretation of the results (3, 11). Thus, the selection of the control group represents a step as important as the selection of the experimental group. Thus, research groups have been showing concern over the time with which strain that should be used as SHR control. Then, multiple studies have compared different variables between SHR, WIS and WKY, aiming to provide a background when selecting strains for the scientific researches (20-32). Thus, this work aimed to map studies that used the WIS and WKY strains simultaneously as SHR control, allowing the proper characterization of the available variables of strains.

2- Methods:

The elaboration of this scoping review followed the criteria established by the *Preferred Reporting Items for Systematic Reviews and Meta-analysis* with extension for scoping reviews (PRISMA-ScR) (33, 34). The methodological protocol used was registered in the *Open Science Framework* and can be consulted from the following electronic address: https://osf.io/e7kfm/?view_only=.

The works were searched in electronic databases (PubMed, Web of Sciences and EMBASE), in addition to the search in the references of the selected articles themselves. The following descriptors were defined with the aid of Medical Subject Headings (MeSH): “*Spontaneously hypertensive rat OR SHR AND Wistar Kyoto OR Normotensive Wistar Kyoto Rat OR WKY AND Wistar OR Normotensive Wistar Rat OR WIS OR NWR*“.

After searching for papers in the databases, duplicates were eliminated using the *Mendeley* software. Two reviewers independently analyzed the titles (phase 1) and abstracts (phase 2) of all studies identified by the searches. Complete studies (Phase 3) considered potentially relevant for inclusion after discussion between the reviewers were then be obtained and two evaluated them for eligibility. Data were extracted from the studies chosen to be included using a standard form, prepared previously. Any discrepancies were discussed with a third reviewer. This process was performed using *Rayyan*, a Web application designed to assist in this step of the review studies.

The research including all original studies that used simultaneous comparison among WIS, WKY and SHR. Therefore, the exclusions criterions were: a) qualitative studies; b)

studies that did not use the three strains, i.e.; only WIS or WKY as control; used the SHR as control; used another strain as control; c) review studies.

The data extraction form was previously established, in which information was obtained about: 1) study/year; 2) country in which the research was carried out; 3) laboratory of source the experimental strains; 4) age at which they were used; 5) sex of the animals used; 6) body mass; 7) blood pressure and the method used for its analysis; 8) main analysis carried out and its results; 9) relationship of the responses between normotensive rats from the analyzes carried out.

3- Results:

The stages of the article search process are shown in the flowchart (fig.1). After descriptors application in databases were founded 28676 studies. The duplicates were founded and excluded (n= 5584) using *Mendeley* version 1.17.13 (Elsevier), remaining 23092 articles. The exclusions criterions were applied and 190 papers resting to be read in full. After reading, 29 more studies were excluded because they did not perform a comparative analysis between the three strains, and 161 articles were finally included for data extraction.

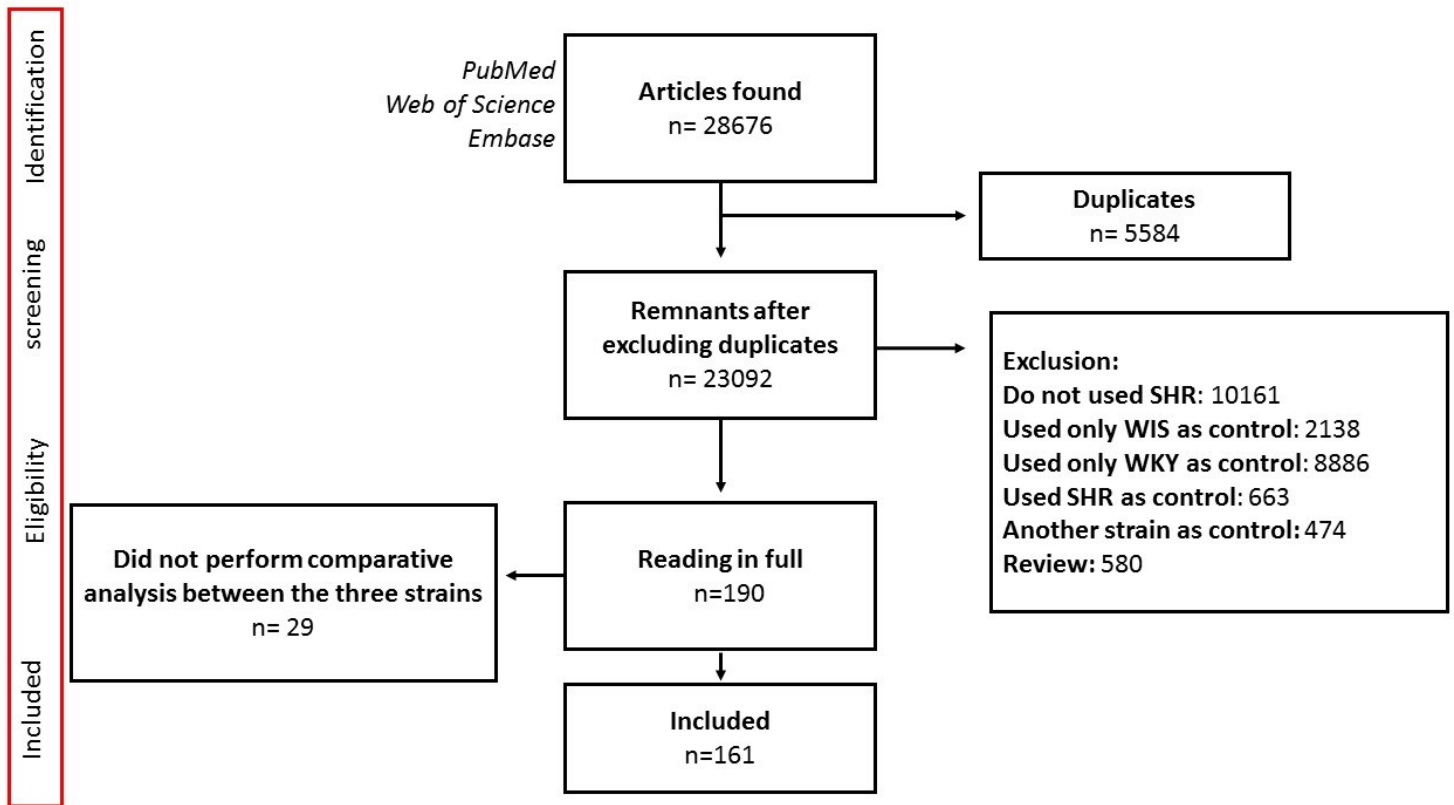

Figure 1. Flowchart of searching process.

Figure 2 shows the annual frequency of articles found in the search ($n = 23092$; fig.2A), in which we highlight the year of development of the SHR (1963) (5). In panel B we present the starting point at which the researchers comparing the three experimental models (1974), as well as the annual frequency of studies within this theme.

Figure 3 is a map showing all the countries that have developed scientific works comparing the three strains studied. Researches were found in 23 countries and on all continents, with the Americas ($n = 99$) and Europe ($n = 44$) consisting of the most active continents within this theme.

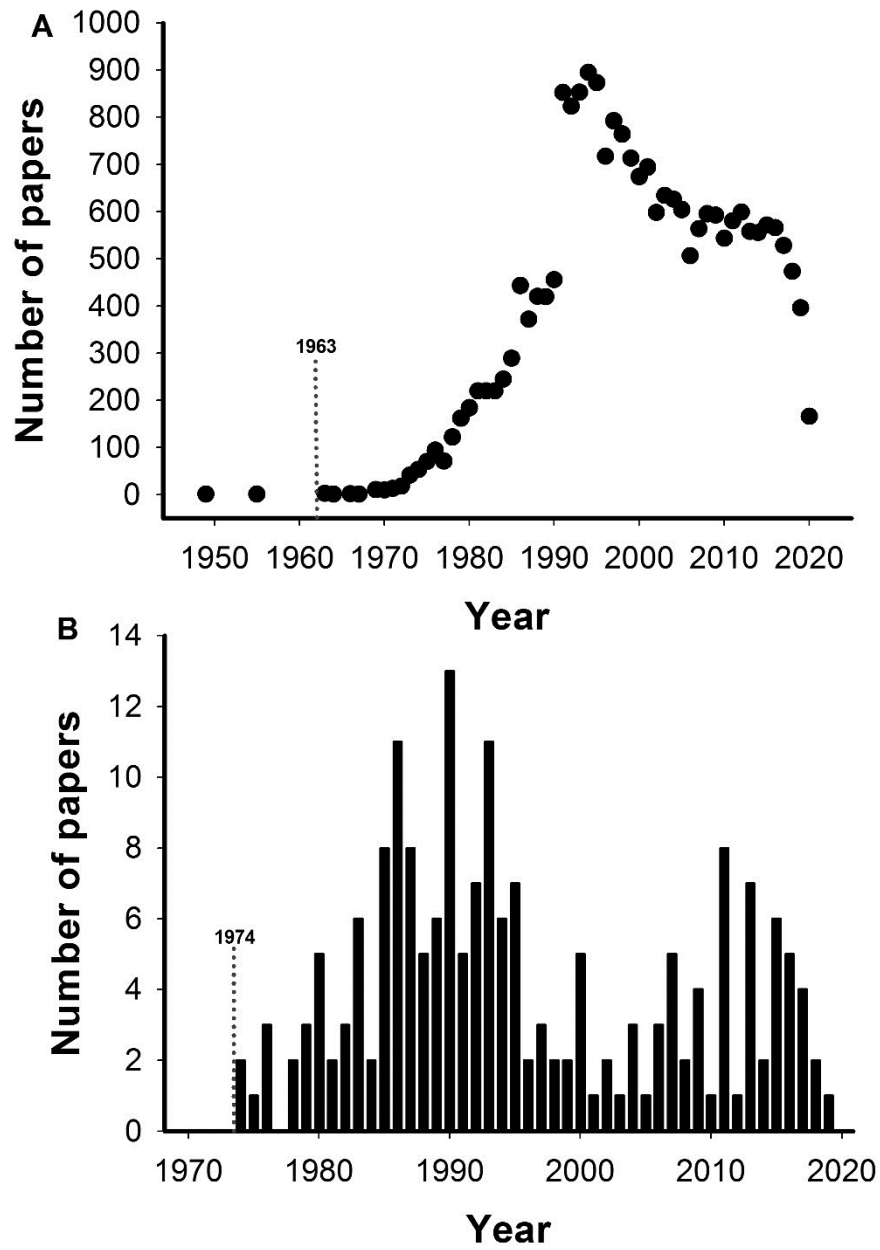

Figure 2. Annual flow of research found from searches ($n = 23092$; panel A) and annual flow of research that compared the three experimental models (panel B).

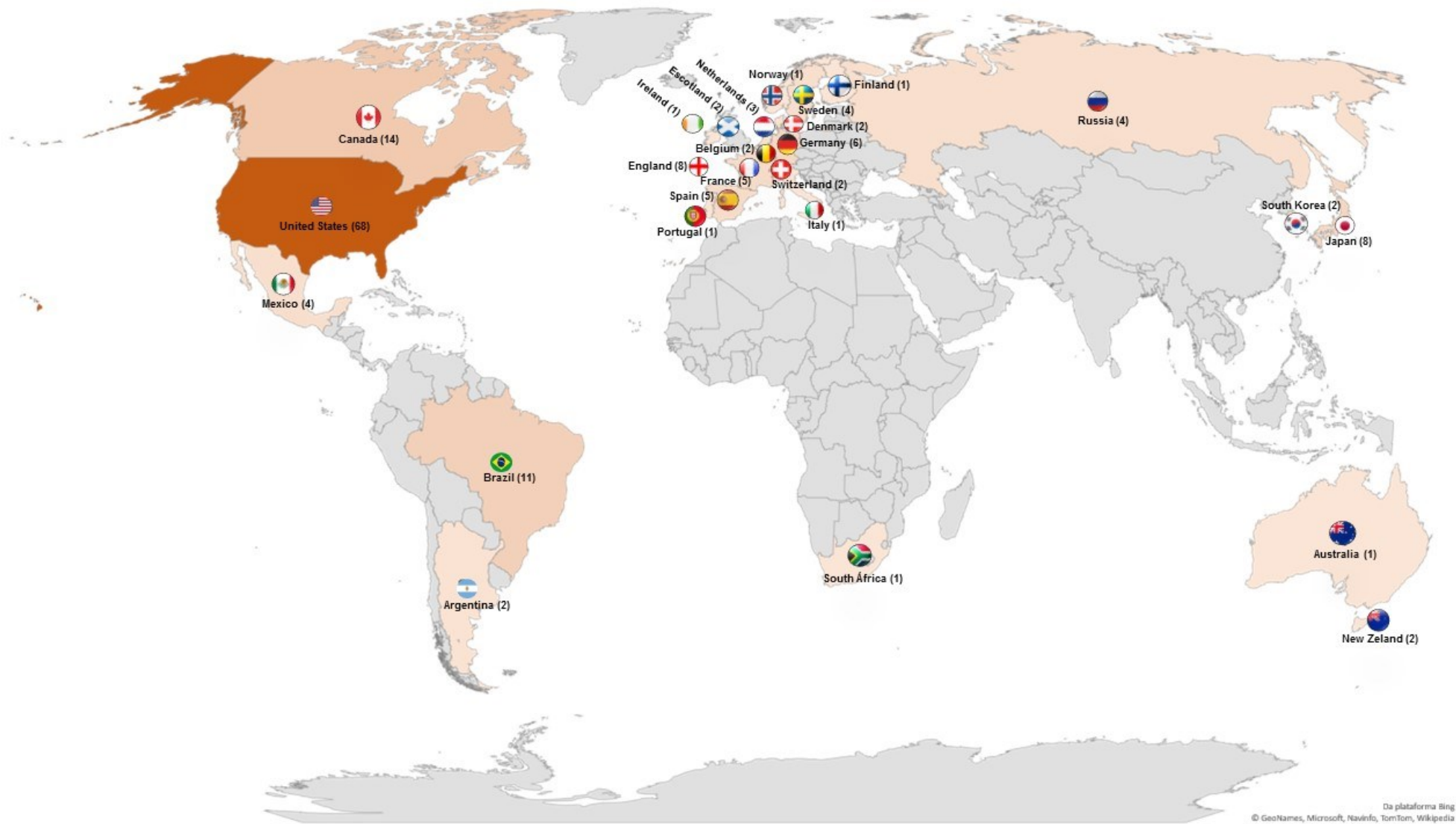

Figure 3. Map of countries that developed research comparing the three strains. The intensity of coloring indicates the density of studies in each location.

Table 1 shows which laboratories and the number of times that each animal breeding laboratory provided rats for researches. It is important to note that 34 studies did not indicate the source of origin of the experimental animals used.

Table 1. Laboratories of experimental strains origin.

Source	WIS	WKY	SHR
Charles-River Breeding Laboratories, Wilmington, Massachusetts- USA	14	17	18
Charles-River Breeding Laboratories, Burlington, Massachusetts- USA	16	4	4
Charles River Breeding Laboratories, Margate- USA	1	2	2
Charles River Laboratories, Raleigh, North Carolina- USA	5	2	2
Charles River Laboratories, Kingston, New York- USA	2	5	5
Charles River Laboratories, St-Constant, Quebec- Canada	9	4	4
Charles River Wiga GmbH, Sulzfeld- Germany	2	2	3
Charles River Laboratories, Kisslegg- Germany	2	2	2
Charles River Laboratories, Yokohama- Japan	2	2	2
Charles River Laboratories, Shizuoka- Japan	1	1	1
Charles River Laboratories, Atsugi- Japan	x	1	1
Charles River Breeding Laboratories- United Kingdom	1	x	1
Charles River Breeding Laboratories- Spain	1	1	1
Charles River Laboratories, Lyon- France	4	4	4
Charles-River Breeding Laboratories (not indicated local)	12	10	10
Harlan Laboratories, Frederick- USA	1	x	x
Harlan Laboratories, Bicester- England	2	3	2
Harlan Sprague Dawley, Indianapolis- USA	7	9	8
Harlan Laboratories- Netherlands	1	1	1
Harlan Laboratories, Mexico City- Mexico	3	x	x
Harlan Laboratories- United Kingdom	x	1	x
Wistar Institute, Philadelphia- USA	5	2	2
Mollegaard Breeding Farm, Skensved- Denmark	5	6	6
Biological Laboratories, Ballina- Ireland	1	x	1
Ivanovas Kisleg im Algau, FRG- Germany	1	x	1
Clinical Research Institute of Montreal- Canada	x	1	1
IFFA, Credo, Lyon- France	2	2	2
Versuchstierzucht Schönwalde- Germany	1	x	x
Central institute of Cardiovascular research- Germany	x	1	1
National institutes of Health stock- USA	x	1	1
Breeding colony in Chapel Hill, North Carolina- USA	2	1	1
University of Connecticut School of Medicine, Farmington- USA	1	1	1
Le Genest-Saint-Isle- France	1	1	1
Madörin ag, Füllinsdorf- Switzerland	1	1	1
Central Research Laboratory of the Ministry of Public Health of the USSR, Moscow- Russia	x	1	1
USSR Academy of Medical Sciences- Russia	1	x	x

National Heart and Lung Institute- England	x	1	x
Carworth farm, Missouri- USA	1	x	1
National Institutes of Health, Bethesda, Maryland- USA	1	5	5
Paulist school of medicine, São Paulo- Brazil	2	1	1
Laboratory Supplx- Co. Indianapolis- USA	2	2	2
West Jersey Biological Supply , New Jersey- USA	1	x	x
Merrell National Laboratories, Cincinnati, Ohio- USA	x	x	1
Taconic Farms, Germantown, New York- USA	8	14	14
Microbiological Associates, Walkersville, Maryland- USA	1	x	x
Simonsen Laboratories, Gilroy, California- USA	1	x	x
University of the Pacific, San Francisco- USA	x	1	1
Rockland, Gilbertsville, Pennsylvania- USA	1	x	x
University of Bristol, University Walk, Bristol- England	1	x	x
Dr Karl Thomae GmbH- Germany	1	x	x
Shizuoka Laboratory Center, Hamamatsu- Japan	1	x	x
school of medical sciences- Argentina	1	x	x
Disease Model Cooperative Research Association, Kyoto- Japan	x	1	1
Centre d'Elevage René Janvier- France	1	1	1
University of New South Wales, UNSW, Sidney- Australia	x	1	1
animal care facility of the Department of Neurology, School of Medicine of Ribeirao Preto- Brazil	1	1	1
Pavlov Institute of Physiology, Saint Petersburg- Russia	1	1	1
Central Institute for the breeding of Laboratory Animals, Zeist- Netherlands	2	3	3

Legend: x- without collecting models in this lab

Table 2. presented the data of papers. The works were detailed as to study/year, country in which the research was carried out, laboratory of source the experimental strains, age at which they were used, sex of the animals used, body mass, blood pressure and the method used for its analysis, main analysis carried out and its results and relationship of the responses between normotensive rats from the analyzes carried out.

Table 2. *Characterization of Wistar, Wistar Kyoto and SHR.*

Study	Country	Gender	Age	Origin	Body mass	Blood pressure	Measurement	Results	Control group
Tobia, Lee and Walsh (1974)	USA	Male	5 to 8 months	WIS and SHR- Carworth farm , Missouri- USA WKY-National Institutes of Health, Bethesda, Maryland, USA	NI	Direct registration of MAP from catheter in carotid artery WIS: 99 ± 4 mmHg WKY: 114 ± 7 mmHg SHR: 183 ± 12 mmHg	Regional blood flow of iliac and mesenteric arteries	SHR: ↑ Peripheral resistance index WIS vs. WKY: ↑ Total peripheral resistance	WKY better control
Frohlich and Pfeffer (1975)	USA	NI	8 to 11 weeks	WIS and SHR- University of Oklahoma, Health Sciences Center from animals, USA WKY- National Heart and Lung Institute, England	WIS: 225 g WKY: 221 g SHR: 210 g	Direct registration of SBP from catheter in carotid artery WIS: 143 mmHg WKY: 134 mmHg SHR: 185 mmHg	Blood pressure LVM Peripheral resistance index	SHR: ↑ SBP ↑ LVM ↑ Peripheral resistance index WIS = WKY	WIS = WKY
Nickerson (1976)	USA	Male	21 weeks	WIS and SHR- Charles-River Breeding Laboratories, Wilmington, Massachusetts-USA WKY- Laboratory Supply Company, Indianapolis, IN, USA	WIS: 467 ± 9g WKY: 344 ± 8g SHR: 286 ± 6g	SBP: Method was not indicated WIS: 113 ± 2 mmHg WKY: 105 ± 4 mmHg SHR: 172 ± 6 mmHg	Ultrastructure of the adrenal gland	WKY vs WIS: ↑ Adrenal gland weight Organel Volume in zona glomerulosa: ↓ mitochondria smooth endoplasmic reticulum, ↑ lysosomes	WKY better control
Nishiyama, Nishiyama and Frohlich (1976)	USA	Male	18 to 25 weeks	WIS- West Jersey Biological Supply , New Jersey-USA WKY and SHR- University of Oklahoma, Health Sciences Center from animals, USA	WIS: 458 ± 15g WKY: 347 ± 7g SHR: 326 ± 6g	Direct registration of MAP from catheter in carotid artery WIS: 111 ± 6 mmHg WKY: 102 ± 4 mmHg SHR: 154 ± 5 mmHg	Organs weight	SHR: ↑ Heart/body mass ratio ↑ Weight of lung ↑ Weight of stomach ↑ Weight of intestine ↑ Weight of liver SHR vs. WIS ↑ Weight of brain ↑ Weight of adrenal glands ↑ Weight of Kidneys WKY vs. WIS: ↑ Weight of brain ↑ Weight of pancreas ↑ Weight of adrenal glans ↓ Weight of liver ↓ Weight of splen	Not conclusive

Mullins and Banks (1976)	USA	Female	6 weeks 12 weeks 16 weeks	WIS and WKY- Laboratory Supply Company, Indianapolis, IN, USA SHR- Merrell National Laboratories, Cincinnati, Ohio- USA	Only shown in graph WIS > SHR	Direct registration of SBP from catheter in femoral artery; and SBP were estimated using the tail-cuff occlusion and plethsmography method Tail WIS: 131 ± 3 mmHg WKY: 102 ± 1.5 mmHg SHR: 148.3 ± 4.1 mmHg Artery WIS: 127.5 ± 4.6 mmHg WKY: 107 ± 2.5 mmHg SHR: 153.8 ± 3.8 mmHg	Kidney weight	SHR: ↓ Kidney weight 6weeks: SHR vs. WIS: ↓ Sodium load excretion 6 vs. 12 weeks: SHR: ↓ Glomerular filtration SHR and WIS: ↑ Kidney weight	WKY better control
--------------------------	-----	--------	---------------------------------	--	----------------------------------	--	---------------	--	--------------------

Hodgins and Frohlich (1978)	USA	NI	4 and 16 weeks	NI	NI	NI	Levels of norepinephrine and serotonin of brain (Paraventricular Nucleus, Locus Coeruleus, Parabrachial Nuclei, Dorsal Motor Nucleus of X, Nucleus Tractus Solitarius and Medullary Raphe Nuclei)	<p>Paraventricular Nucleus: 4 weeks: ↑ 5HT (WIS)</p> <p>Locus Coeruleus: 4 weeks: ↑ 5HT (WIS) 16 weeks: ↑ NE (WIS)</p> <p>Parabrachial Nuclei: 4 weeks: ↓ NE (WKY) ↑ 5HT (WIS) 16 weeks: ↑ NE (WIS)</p> <p>Dorsal Motor Nucleus of X: 4 weeks: ↓ NE (WKY) 16 weeks: ↑ 5HT (SHR)</p> <p>Nucleus Tractus Solitarius: 4 weeks: ↑ 5HT (WKY)</p> <p>Medullary Raphe Nuclei: 4 weeks: ↑ 5HT (WIS) 16 weeks: ↓ 5HT (WIS)</p>	Not conclusive
-----------------------------	-----	----	----------------	----	----	----	---	--	----------------

Dunn, Pfeffer e Frohlich (1978)	USA	Male and female	8 to 12 weeks 26 to 51 weeks 51 to 76 weeks > 76 weeks	University of Oklahoma, Health Sciences Center from animals, USA	WIS: 239g; 449g; 397g; 328g. WKY: 189g; 354g; 372g; 447g. SHR: 218g; 309g; 298g; 313g.	NI	LVM/BM echocardiogram	SHR: ↑ LVM/BM > 51 weeks SHR: ↑ P wave duration ↑ QRS duration WIS = WKY	WIS = WKY
Hodgins and Frohlich (1978)	USA	NI	14 to 63 weeks	NI	WIS: 290 ± 84g WKY: 255 ± 20g SHR: 222 ± 26g	NI	LVM/BM enzymatic activity in left ventricle after norepinephrine stimulation: Adenylate cyclase and lactate Dehydrogenase.	SHR: ↑ LVM/BM ↑ Lactate Dehydrogenase activity SHR vs. WKY: ↓ Adenylate cyclase activity:	WIS = WKY
Cox (1979)	USA	NI	10 weeks	Charles-River Breeding Laboratories	WIS: 305 ± 9g WKY: 269 ± 13g SHR: 245 ± 5g	SBP were estimated using the tail-cuff occlusion and plethysmography method WIS: 121 ± 3mmHg WKY: 124 ± 4mmHg SHR: 187 ± 5mmHg	Geometric properties of carotid collagen content	SHR: ↑ SBP ↓ Internal radius of carotid ↓ External diameter SHR vs. WKY ↑ stiffening of carotid ↑ collagen	WIS = WKY

Johnson and macia (1979)	USA	NI	10 to 12 weeks	WIS: Charles-River Breeding Laboratories WKY and SHR- National Institutes of Health, Bethesda, Maryland, USA	NI	Direct registration of MAP from catheter in carotid artery WIS: 166 ± 2 mmHg WKY: 107 ± 9 mmHg SHR: 201 ± 2 mmHg	sympathetic vasomotor outflow and blood pressure after guanethidine infusion	SHR ↑ Resistance to guanethidine WIS = WKY	WIS = WKY
Collis, Mey and Vanhoutte (1979)	Belgium	NI	6 weeks	NI	NI	SBP were estimated using the tail-cuff occlusion and plethysmography method WIS and WKY: 119.5 ± 1 mmHg SHR: 158.3 ± 2.6 mmHg	Perfusion pressure Noradrenalin efflux	SHR: ↑ Perfusion pressure ↑ Noradrenalin efflux WIS = WKY	WIS = WKY
Postnov and Orlov (1980)	Russia	Male	13 weeks	WIS- USSR Academy of Medical Sciences, Russia SHR and WKY- Central Research Laboratory of the Ministry of Public Health of the USSR, Moscow-Russia	WIS: 150 - 175g WKY: 145 - 170g SHR: 140- 160g	SBP were estimated using the tail-cuff occlusion and plethysmography method WIS: 80 - 100 mmHg WKY: 120 - 140 mmHg SHR: 180 - 200 mmHg	Mitochondria calcium accumulation Mitochondria calcium binding capacity of certain membranes	SHR: ↓ Mitochondria calcium accumulation ↓ Mitochondria calcium binding capacity of certain membranes WIS = WKY	WIS = WKY
Altura, Cortella and Altura (1980)	USA	Male	14-16 weeks	Taconic Farms, Germantown, New York	NI	MAP: Method was not indicating WIS: 100-120 mmHg WKY: 100-120 mmHg SHR: 175-200 mmHg	In vivo contraction of VSMC induced by magnesium ions	SHR and WKY vs. WIS: ↑ Isometric tension of VSMC	WIS better control

Nordborg, Barbro and Johansson (1980)	Sweden	Male and female	200 days	NI	NI	Direct registration of MAP from catheter in femoral artery WIS: 100 - 115 mmHg WKY: 100 - 115 mmHg SHR: 150 - 185 mmHg	Morphometry of cerebral arteries	SHR: ↑ Media area of artery SHR vs. WIS: ↑ Media/radius ratio	WIS = WKY
Haack, Schaffer e Simpson (1980)	USA	Male	5 to 10 weeks	Charles-River Breeding Laboratories, Wilmington Massachusetts, EUA	WIS: 212 ± 11 g WKY: 176 ± 8 g SHR: 190 ± 9 g	SBP were estimated using the tail-cuff occlusion and plethysmography method WIS: 124 ± 3 mmHg WKY: 115 ± 5 mmHg SHR: 149 ± 4 mmHg	Blood vessels count Blood vessels diameter	SHR: ↑ SBP ↓ Fourth-order arterioles ↑ Mean internal diameters SHR and WKY vs. WIS: ↓ Third-order arterial vessels SHR vs. WIS: ↓ Fourth-order veins WKY vs. WIS: ↓ Fourth-order arterioles WIS, WKY and SHR: ↓ MAP after vasodilating agents infusion SHR: ↓ MAP after vasodilating agents infusion WIS = WKY	WIS better control
Lukacsko, Messina and Kaley (1980)	USA	Male	210 to 225 days	Charles-River Breeding Laboratories	NI	Direct registration of MAP from catheter in carotid artery WIS: 107 ± 3 mmHg WKY: 114 ± 4 mmHg SHR: 143 ± 2 mmHg	MAP after infusion of vasodilating agents (prostaglandin, prostacyclin, arachidonic acid and sodium nitroprusside)	SHR: ↓ MAP after vasodilating agents infusion SHR: ↓ MAP after vasodilating agents infusion WIS = WKY	WIS = WKY
Webb, Vanhoutte and Bohr (1980)	Belgium	Male and female	3.5 to 6 months	WIS and WKY- Charles-River Breeding Laboratories, Wilmington Massachusetts, EUA SHR- University of Antwerp, Belgium	NI	SBP were estimated using the tail-cuff occlusion and plethysmography method WIS and WKY: 124 ± 2 mmHg SHR: 183 ± 3 mmHg	Arterial contraction strength	SHR ↓ Maximum contractile response ↓ % Maximum response to norepinephrine WIS = WKY	WIS = WKY

O'donnel and Volicer (1981)	USA	Male	12 weeks	Charles-River Breeding Laboratories, Burlington, Massachusetts, EUA	NI	SBP were estimated using the tail-cuff occlusion and physiograph method WIS: 111 ± 7 mmHg WKY: 115 ± 7 mmHg SHR: 185 ± 4 mmHg	Tcore response to temperature stimulus	SHR: ↑ Basal temperature ↑ Tcore increased after heating ↑ Tcore decreased after cooling WIS = WKY	WIS = WKY
Kitamura et al. (1981)	USA	Female	WIS and WKY: 8 ± 0.2 weeks SHR: 33 ± 1 weeks	NI	NI	MAP was recorded on multichannel polygraph WIS: 112 ± 3 mmHg WKY: 107 ± 4 mmHg SHR: 162 ± 4 mmHg	Cardiac output total vascular resistance organ vascular resistance after injury induction in STN	Pre injury: SHR: ↑ MAP ↑ Total peripheral resistance ↑ organ vascular resistance (brain, heart, lungs, hepatosplanchnic, kidneys) SHR vs. WIS: ↓ Cardiac output After injury: SHR, WIS and WKY: ↑ MAP ↑ Total peripheral resistance WIS and WKY: ↓ Cardiac output WIS = WKY	WIS = WKY
Lundin et al. (1982)	Sweden	Male	7 Weeks (WIS and SHR) 16 Weeks (WKY and SHR)	Taconic Farms, Germantown, New York	7 Weeks: WIS: 164 ± 2 g SHR: 127 ± 2 g 16 Weeks: WKY: 289 ± 3 g SHR: 285 ± 3 g	Direct registration of MAP from catheter in tail artery: 7 Weeks: WIS: 109 ± 3 mmHg SHR: 122 ± 2 mmHg 16 Weeks: WKY: 105 ± 3 mmHg SHR: 155 ± 4 mmHg	Sodium retention/excretion	WIS = WKY = SHR	WIS = WKY

Mullins et al. (1982)	USA	NI	5, 10, 15, 20, 25 and 30 days	Charles-River Breeding Laboratories	NI	NI	Plasma aldosterone	5, 10 and 20 days: SHR vs. WKY: ↑ Aldosterone concentration 5, 10, 20 and 30 days: SHR vs. WIS: ↑ Aldosterone concentration WKY: ↑ Aging Aldosterone concentration WIS = WKY	WIS = WKY
Piccoti et al. (1982)	Italy	Male	SHR and WKY: 13 to 14 weeks	University of Oklahoma, Health Sciences Center from animals, USA	220 - 300g	Direct registration of MAP from catheter in carotid artery WIS: 111 ± 2 mmHg WKY: 125 ± 4 mmHg SHR: 183 ± 4 mmHg	Catecholamines concentration after cold exposure	WIS: ↑ Catecholamines concentration SHR: ↑ MAP	WIS better control

Lukacsko (1983)	USA	Male	5, 10 and 20 weeks	Charles-River Breeding Laboratories	NI	NI	Arterial prostaglandins release with and without AA stimulation	<p>5 weeks: Without AA: SHR vs. WKY: ↑ Prostaglandin release With AA: ↑ Prostaglandin release (all strains)</p> <p>10 weeks: SHR and WIS vs. WKY: ↑ Prostaglandin release With AA: ↑ Prostaglandin release (all strains)</p> <p>20 weeks: SHR vs. WIS and WKY: ↑ Prostaglandin release With AA: ↑ Prostaglandin release (all strains) WIS = WKY</p>	WIS = WKY
-----------------	-----	------	--------------------	-------------------------------------	----	----	---	---	-----------

Borkowski and Quinn (1983)	England	Male	NI	NI	250-300g	Direct registration of SBP from catheter in femoral artery; and SBP were estimated using the tail-cuff occlusion and oscilograph method Tail WIS: 111 ± 6mmHg WKY: 151 ± 5mmHg SHR: 174 ± 10mmHg Artery WIS: 119 ± 3mmHg WKY: 157 ± 5mmHg SHR: 178 ± 5mmHg	Catecholamines concentration in both blood pressure measurements methods	Tail SHR: ↑ Catecholamines concentration WIS = WKY	WIS = WKY
Häusler et al. (1983)	Switzerland	Male	NI	Madörin ag, Füllinsdorf, Switzerland	NI	SBP were estimated using the tail-cuff occlusion and plethysmography method Showed only in graph	Hypothalamus pituitary adrenocortical function after betamethasone ingestion	SHR and WKY vs WIS: ↑ SBP after betamethasone ingestion SHR ↓ ACTH content after betamethasone ingestion ↑ Relative pituitary weight	WIS better control
Takahashi et al. (1983)	Japan	Male	16 weeks	NI	WIS: 250 ± 5g WKY: 289 ± 7g SHR: 244 ± 4g	Direct registration of MAP from catheter in femoral artery WIS: 115 ± 6 mmHg WKY: 123 ± 6 mmHg SHR: 156 ± 6 mmHg	Sympathetic nerver activity Vascular responsiveness to Carbachol	Carbachol WIS: ↓ MAP follow by increase ↑ Sympathetic nerver activity WKY and SHR vs. WIS: ↑ MAP	WIS better control
Preuss and Goldin (1983)	USA	NI	25 weeks	WIS- Microbiological Associates, Walkersville, Maryland, USA SHR and WKY- Taconic Farms, Germantown, New York- USA	WIS: 158 ± 7.4 - 206 ± 24g WKY: NI SHR: 145 ± 9.2g - 201 ± 10.1g	NI	Renotropic activity	SHR: ↑ Kidneys weight ↑ Renotropins ↑ Renotropic activity WIS = WKY	WIS = WKY

Martin and Quock (1984)	USA	Male	12 - 15g	WIS- Simonsen Laboratories, Gilroy, California-USA WKY and SHR- University of the Pacific, San Francisco-USA	250 - 300g	SBP were estimated using the tail-cuff occlusion and plethysmography method WIS: 131 ± 1 mmHg WKY: 135 ± 1 mmHg SHR: 202 ± 1 mmHg	Body temperature after apomorphine application thermal response index	SHR: ↑ Thermal response index ↑ Hypothermic responses WIS = WKY	WIS = WKY
Krukoff and Calaresu (1984)	Canada	Male	NI	Charles-River Breeding Laboratories	300 ± 30 g	Direct registration of MAP from catheter in femoral artery WIS: 112 ± 3 mmHg WKY: 104 ± 3 mmHg SHR: 156 ± 2 mmHg	Celular COX activity in hypothalamus	SHR: ↑ Cox activity (PVH and SON) WIS = WKY	WIS = WKY
Miasiro et al. (1985)	Brazil	NI	20 - 24 weeks	WIS- Wistar Institute, Philadelphia, PA, USA WKY and SHR- National Institutes of Health, Bethesda, Maryland, USA	WKY: 210 - 230g SHR: 170 - 190g	NI	reactivities to bradykinin and to increased K ⁺ of duodenum VSMC	SHR and WkY vs. WIS: ↓ Contraction ↑ Sensitive to bradykinin	Not conclusive
Loeb and Bean (1985)	USA	Male and female	4 - 21 weeks	WIS- Harlan Laboratories Inc, Frederick, USA Charles-River Breeding Laboratories, Wilmington massachusetts-USA	WIS: 190 - 250g WKY: NI SHR: NI	SBP were estimated using the tail-cuff occlusion and plethysmography method Showed only in graph	Aortic DNA synthesis of smooth muscle	> 17 weeks: SHR: ↑ Aortic DNA synthesis WIS = WKY	WIS = WKY
Hard et al. (1985)	Sweden	Male and female	87 - 180 days	Mollegaard Breeding Farm, Skensved, Denmark	NI	Direct registration of MAP from catheter in tail artery show only in graph	Locomotor behavior Sexual behavior	SHR vs. WKY: ↑ Locomotor activity WIS vs. WKY: ↑ Sexual behavior	Suggests using both

Kino et al. (1985)	USA	Male	14 - 17 weeks	NI	NI	SBP were estimated using the tail-cuff occlusion and plethysmography method WIS: 109.1 ± 6.6 mmHg WKY: 116.5 ± 3.8 mmHg SHR: 218.5 ± 2.4 mmHg	Intracellular Na ⁺ /K ⁺ ratios in VSMC	SHR: ↑ Rb ⁺ efflux ↑ Peak of Intracellular Na ⁺ /K ⁺ WIS = WKY	WIS = WKY
Farmam and Bonvalet (1985)	France	Femele	NI	NI	190 - 210g	Direct registration of MAP from catheter in femoral artery WIS: 108.7 ± 4.1 mmHg WKY: 111.0 ± 5.4 mmHg SHR: 143.0 ± 2.2 mmHg Direct registration of DBP from catheter in carotid artery WIS: 109.3 ± 5.3 mmHg WKY: 94.4 ± 5.7 mmHg SHR: 140.4 ± 2.9 mmHg	Kidneys aldosterone binding	SHR vs. WIS: ↑ Cortical collecting tubles ↑ Medullary collecting duct WKY vs. WIS: ↑ Cortical collecting tubles	Not conclusive
Docherty and Warnock (1986)	Ireland	Male	2 to 3 months	WIS and SHR- Biological Laboratories, Ballina, Ireland WKY- Harlan Laboratories, Bicester, England	WIS: WKY: SHR: 250 - 300g	Direct registration of DBP from catheter in carotid artery WIS: 109.3 ± 5.3 mmHg WKY: 94.4 ± 5.7 mmHg SHR: 140.4 ± 2.9 mmHg	Vas deferentia isometric contraction after electric stimulation and infusion of vasodilator drugs	Drugs infusion: SHR: ↓ Maximum potential of contraction WIS = WKY	WIS = WKY
Hopp et al. (1986)	USA	Male	NI	Charles-River Breeding Laboratories	250 - 300g	SBP were estimated using the tail-cuff occlusion and plethysmography method WIS: 119.8 ± 3.2 mmHg WKY: 126.6 ± 1.7 mmHg SHR: 204.8 ± 4.1 mmHg	Ouabain binding in VMSC from carotid arteries	WIS: ↑ Na ⁺ pumps units ↓ Equilibrium dissociation for ouabain in VSMCs	WIS better control
Leysac, Jensen and Holstein-Rathlou (1986)	Denmark	Male	NI	WIS- Ivanovas Kisleg im Algau, FRG , Germany WKY and SHR-Mollegaard Breeding Farm, Skensved, Denmark	230 - 300g	Direct registration of SBP from catheter in carotid artery Show only a graph	Proximal tubular compliance in rats anaesthetized with inactin and halothane	Inactin > halothane ↑ tubular compliance SHR = WIS = WKY	WIS = WKY

Tamura et al. (1986)	USA	Male	NI	NI	230 - 300g	SBP were estimated using the tail-cuff occlusion and plethysmography method WIS: 119.8 ± 3.2 mmHg WKY: 126.6 ± 1.7 mmHg SHR: 204.8 ± 4.1 mmHg	Na ⁺ -K ^e regulatory system in VSMC	SHR: ↑ K ⁺ values ↑ Na ⁺ pump activity WIS = WKY	WIS = WKY
Tokushige et al. (1986)	USA	Male	NI	NI	230 - 300g	SBP were estimated using the tail-cuff occlusion and plethysmography method WIS: 107.7 ± 4.2 mmHg WKY: 117.3 ± 4.4 mmHg SHR: 190.3 ± 4.1 mmHg	Bumetanide- sensitive Na ⁺ transport in VSMC	SHR: ↑ Bumetanide- sensitive Na ⁺ transport in VSMC ↑ Na ⁺ turnover WIS = WKY	WIS = WKY
Head and Jong (1986)	Netherlands	Male	NI	Central Breeding Laboratories TNO, Zeist, The Netherlands	200 - 380g	Direct registration of MAP from catheter in tail artery WIS: 113 ± 2 mmHg WKY: 126 ± 2 mmHg SHR: 169 ± 4 mmHg	BP response after clonidine infusion	SHR: ↑ Decreased of MAP after drug infusion WKY vs. WIS: ↑ Decreased of MAP after drug infusion	WIS better control
Toivanen et al. (1986)	Finland	Male and female	NI	WIS- Mollegaard Breeding Farm, Skensved, Denmark WKY and SHR- Central Institute for the breeding of Laboratory Animals, Zeist- Netherlands	280 - 330g	NI	Arthritis induced by yersinia pseudotuberculosis infusion	SHR: ↑ Arthritis infection WIS = WKY	WIS = WKY

Gattone (1986)	USA	Male and female	newborns 1 to 6 weeks	Charles-River Breeding Laboratories, Wilmington, massachusetts-EUA	NI	Body weight gain	<p>Newborn: WIS- 6.06 ± 0.17g WKY- 4.87 ± 0.09g SHR- 5.01 ± 0.08g 1 week: WIS- 15.6 ± 0.46g WKY- 10.5 ± 0.23g SHR- 8.9 ± 0.32g 2 week: WIS- 34.7 ± 0.94g WKY- 23.9 ± 0.95g SHR- 17.7 ± 0.33g 3 week: WIS- 45.8 ± 1.28g WKY- 32.9 ± 1.54g SHR- 28.4 ± 0.71g 4 week: WIS- 99.8 ± 2.89g WKY- 65.2 ± 1.29g SHR- 57.8 ± 1.08g 6 week: WIS- 178.9 ± 6.38g WKY- 116.5 ± 3.32g SHR- 103.7 ± 2.46g</p>	<p>Newborn: WIS vs. SHR and WKY ↑ Body weight 1 week: WIS vs. SHR and WKY: ↑ Body weight WKY vs. SHR : ↑ Body weight 2 weeks: WIS vs. SHR and WKY: ↑ Body weight WKY vs. SHR: ↑ Body weight 3 weeks: WIS vs. SHR and WKY: ↑ Body weight WKY vs. SHR: ↑ Body weight 4 weeks: WIS vs. SHR and WKY: ↑ Body weight WKY vs. SHR: ↑ Body weight 6 weeks: WIS vs. SHR and WKY: ↑ Body weight WKY vs. SHR: ↑ Body weight</p>	<p>WIS = WKY Suggests using bot</p>
-------------------	-----	--------------------	--------------------------	--	----	------------------	---	--	---

Sladek, Davis and Sladek (1986)	USA	Male	15 to 16 weeks	Charles-River Breeding Laboratories	WIS: $327 \pm 7g$ WKY: $224 \pm 1g$ SHR: $283 \pm 4g$	SBP were estimated using the tail-cuff occlusion and plethysmography method WIS: $115 \pm 4mmHg$ WKY: $126 \pm 7 mmHg$ SHR: $174 \pm 3 mmHg$	Catecholamines inervation in supraotic nucleus	SHR and WIS vs. WKY: \uparrow Catecholamines inervation	WKY better control
Feig, D'occhio and Boylan (1987)	USA	NI	4 months	Laboratory Supply Company, Indianapolis- USA	NI	SBP were estimated using the tail-cuff occlusion and plethysmography method WIS: $119.0 \pm 2.7mmHg$ WKY: $121.4 \pm 2.4 mmHg$ SHR: $171.4 \pm 6.0 mmHg$	Lymphocytes volume of timus	SHR: \uparrow Volume gain (NaCl medium) WIS = WKY	WIS = WKY
Sitsen, Nijkamp and Jong (1987)	Netherlands	Male	NI	Central Institute for the breeding of Laboratory Animals, Zeist. Netherlands	225 - 250g	SBP were estimated using the sphygmographic method WIS: 120 - 135mmHg WKY: 1130 - 145mmHg SHR: 190 - 220mmHg	Sensitivity to morphin in: Pain sensitivity Body temperature Tone of smooth muscle Brain concentration of morphine	WIS: \uparrow Analgesic effects of morphin	Not conclusive
Hilgenfeldt and Schott (1987)	Germany	NI	NI	NI	WIS and WKY: 250 - 300g SHR: 200 - 220g	NI	Content of plasma angiotensinogen and turnover of angiotensinogen after nephrectomy	After nephrectomy: SHR: \uparrow increased of angiotensinogen WIS = WKY	WIS = WKY
Khalil et al. (1987)	USA	Male	NI	NI	250 - 300g	SBP were estimated using the tail-cuff occlusion and plethysmography method WIS: $115 \pm 3.3 mmHg$ WKY: $117 \pm 3.0 mmHg$ SHR: $193 \pm 3.0 mmHg$	ANF content in VSMC of carotid ANF receptor density in VSMC ANF content in plasma	SHR: \uparrow ANF receptor density \uparrow ANF content WIS = WKY	WIS = WKY

Lang and Johns (1987)	USA	Male	5 to 8 weeks	NI	NI	Direct registration of MAP from catheter in tail artery WIS: 103.1 ± 1.3 mmHg WKY: 99.9 ± 2.1 mmHg SHR: 125.2 ± 1.5 mmHg	Venule distension	WIS = WKY = SHR	WIS = WKY
Coskinas and Price (1987)	USA	Male and female	16 to 19 weeks	Charles-River Breeding Laboratories	WIS: 273 ± 6 g WKY: 206 ± 3 g SHR: 193 ± 4 g	SBP were estimated using the tail-cuff occlusion and electrosphygmomanometer method WIS: 110 ± 6 mmHg WKY: 106 ± 2 mmHg SHR: 156 ± 2 mmHg	length-sensitivity response in the aorta artery stimulated for epinephrine	WIS = WKY = SHR	WIS = WKY
Kunes et al. (1987)	Canada	NI	newborn	WIS- Taconic Farms, Germantown, New York WKY and SHR- Clinical Research Institute of Montreal- Canada	WIS: 5.69 ± 0.04 g WKY: 5.00 ± 0.06 g SHR: 4.78 ± 0.04 g	NI	Organs weight	Heart: ↑ SHR Heart/body weight ratio: ↑ SHR ↑ WKY vs. WIS Kidneys: ↑ SHR Kidneys/body weight ratio: ↑ SHR ↑ WKY vs. WIS Liver: ↑ WIS Kidneys/body weight ratio: ↑ WIS vs. SHR	WIS better control
Nakamura et al. (1988)	USA	Male	NI	NI	250 - 300g	NI	Atrial natriuretic factor binding in VSMC	SHR: ↑ Binding sites ↑ Density of atrial natriuretic factor WIS = WKY	WIS = WKY

Belichard, Pruneau and Rochette (1988)	France	Male	23 weeks	Iffa Credo, Lyon, France	WIS: 392 ± 6g WKY: 387 ± 4g SHR: 357 ± 5g	Direct registration of SBP from catheter in tail artery WIS: 116 ± 4 mmHg WKY: 123 ± 5 mmHg SHR: 190 ± 3 mmHg	Left ventricular hypertrophy Ventricular fibrillation	SHR: ↑ Left ventricular hypertrophy ↑ Ventricular fibrillation ↑ Duration of ventricular fibrillation WIS = WKY	WIS = WKY
Larivière et al. (1989)	Canada	NI	4,8,12, and 16 weeks	Charles River Laboratories, St-Constant, Quebec, Canada	4 weeks: WIS: 77 ± 3g WKY: 58 ± 3g SHR: 51 ± 2g 8 weeks: WIS: 241 ± 6g WKY: 148 v 6g SHR: 151 ± 6g 12 weeks: WIS: 360 v 6g WKY: 228 ± 5g SHR: 240 ± 1g 16 weeks: WIS: 398 v 5g WKY: 262 ± 11g SHR: 290 ± 2g	SBP were estimated using the tail-cuff occlusion and polygraph method 4 weeks: WIS: 92 ± 2mmHg WKY: 96 ± 2mmHg SHR: 100 ± 2mmHg 8 weeks: WIS: 108 ± 2mmHg WKY: 103 ± 2mmHg SHR: 118 ± 3mmHg 12 weeks: WIS: 111 ± 2mmHg WKY: 110 ± 2mmHg SHR: 138 ± 2mmHg 16 weeks: WIS: 113 ± 2mmHg WKY: 102 ± 5mmHg SHR: 154 ± 2mmHg	vascular vasopressin receptors Vasopressin plasmatic concentration Vasopressin binding sites	SHR: ↑ Efficacy to AVP to contract mesenteric blood vessels ↑ Responsiveness to vasopressin WKY: ↓ Vasopressin plasmatic concentration	WKY better control
Paré (1989)	USA	Male	120 to 135 days	Charles-River Breeding Laboratories, Wilmington, massachusetts-EUA	NI	NI	Behavioral despair	WKY: ↑ Behavioral despair	WKY used as behavior disorder model

Paré (1989)	USA	Male	NI	Charles-River Breeding Laboratories, Wilmington, massachusetts-EUA	NI	NI	Stresse induced ulcer	WKY: ↑ Stresse induced ulcer ↑ Inactive	WKY used as behavior disorder model
Paré (1989)	USA	Male	50 - 79 days	NI	NI	NI	Cumulative ulcer scores Emotional behavior Behavioral despair	WKY: ↑ cumulative ulcer scores ↑ Emotional ↑ Behavioral despair ↑ Depressive strain	WKY used as behavior disorder model
Garcia et al. (1989)	Canada	NI	3 to 15 weeks	Taconic Farms, Germantown, New York	Show only a graph	SBP were estimated using the tail-cuff occlusion and plethysmography method Show only a graph	Plasma ANF levels Heart ANF levels Density of glomerular ANF receptors	ANF in the right atrium: 4 weeks: ↑ SHR 8 weeks: ↑ WKY 12 weeks: ↓ SHR ANF in the left atrium: 4 and 8 weeks: ↑ WIS 12 weeks: ↓ SHR ANF plasma levels: 4 weeks: ↑ SHR vs WIS 8 and 16 weeks: ↑ SHR Density of glomerular ANF receptors : 8, 12 and 16 weeks ↑ WIS and WKY vs. SHR WIS = WKY	WIS = WKY

Rodionov et al. (1989)	Russia	Male	8 to 10 months	NI	NI	SBP Method was not indicated WIS: 110 ± 3.4 mmHg WKY: 117 ± 2.3 mmHg SHR: 194 ± 4.3 mmHg	Gangliar number of neurons resistance to hypoxia	SHR and WKY vs. WIS: ↑ Gangliar number of neurons ↑ resistance to hypoxia	WIS better control
Harris, Grigor and Millar (1990)	New Zeland	NI	15 to 20 weeks	NI	NI	NI	Mitogenic response of VSMC	SHR ↑ Basal thymidina incorporation ↑ Time course to thymidina incorporation WIS = WKY	WIS = WKY
Kawasaki, Saito and Takasaki (1990)	Japan	Male	15 weeks	NI	NI	Direct registration of MAP from catheter in tail artery WIS: 104.6 ± 7.5 mmHg WKY: 97.8 ± 4.3 mmHg SHR: 166.3 ± 3.2 mmHg	Vasodilator response	SHR ↓ Vasodilator response WIS = WKY	WIS = WKY
Sontag, Schälke and Brattström (1990)	Germany	Male	14 to 16 weeks	WIS- Versuchstierzucht Schönwalde, Germany WKY and SHR- Central istitute of Cardiovasular reasearch, Germany	250 - 230g	Direct registration of MAP from catheter in femoral artery WIS: 104.6 ± 7.5 mmHg WKY: 97.8 ± 4.3 mmHg SHR: 166.3 ± 3.2 mmHg	Effect of vasopressin injection into the STN	SHR: ↑ Interbeat interval WKY and WIS: ↑ Interbeat interval ↓ SBP WIS = WKY	WIS = WKY
Stein et al. (1990)	South Africa	Male	NI	NI	250 - 230g	NI	Distribution of Atrial Dense Granules	SHR: ↓ Electron-dense granules ↓ Granule area WIS vs. WKY and SHR: ↑ Large granules	Suggests using both

Alexander et al. (1990)	USA	NI	NI	NI	NI	SBP were estimated using the tail-cuff occlusion and plethysmography method WIS and WKY: <130mmHg SHR: >160mmHg	Aidification of VSMC	WKY: ↓ Na+ dependent alkalization	WKY better control
Morton et al. (1990)	Escotland	Male	3 weeks	Harlan Laboratories, Bicester, England	WIS: 54.4 ± 7.7g WKY: 49.7 ± 4.1g SHR: 50.8 ± 6.1g	Direct registration of intra arterial blood pressure from catheter in carotid artery WIS: 104.6 ± 7.5 mmHg WKY: 81.1 ± 8.7 mmHg SHR: 80.1 ± 6.3 mmHg	Cardiac hypertrophy Vessel morphology	SHR: ↑ Cardiac hypertrophy ↑ Vascular protein in mesnteric arterieres WIS = WKY	WIS = WKY
Dumont, Sabourin and Lamaire (1990)	Canada	Male	4, 8, 12 and 16 weeks	Charles River Laboratories, St-Constant, Quebec, Canada	NI	NI	Cardiac Dyn-A levels	SHR vs. WKY: ↑ Dyn-A levels WIS = WKY	WIS = WKY
Schini, Kim and Vanhoutte (1991)	South Korea	Male	NI	NI	WIS and WKY: 200 - 350g SHR: 200 - 300g	SBP Method was not indicated WIS: NI WKY: NI SHR: 201 ± 5.4 mmHg	Influence of the endothelium on the ontractions evoked by ET-1 and ET-3 in arteries	SHR: ↑ endothelium depressed contractions evokd by ET-1 and ET-3 WIS = WKY	WIS = WKY

Widimský et al. (1991)	Canada	Male	4 to 9 weeks	WIS- Charles River Laboratories, St-Constant, Quebec, Canada WKY and SHR: Taconic Farms, Germantown, New York- USA	WIS: 71 - 309g WKY: 70 - 281g SHR: 65 - 244g	SBP were estimated using the tail-cuff occlusion and plethysmography method shown only a graph	Effects of high salt diet in Plasma ANF levels Plasma renin activity Plasma aldosterone	SHR: ↓ Sodium excretion ↑ ANC levels WIS vs. WKY: ↓ SBP WIS = WKY	WIS = WKY
Pollock and Arendshorst (1991)	USA	Male	10 to 12 weeks	WIS- Chapel Hill Breeding Colonies, North Carolina- USA WKY and SHR- National institutes of Health stock- USA	WIS: 234 ± 11g WKY: 246 ± 8g SHR: 232 ± 7g	Direct registration of intra arterial blood pressure from catheter in femoral artery WIS: 130 ± 6 mmHg WKY: 126 ± 6 mmHg SHR: 151 ± 6 mmHg	Renal vascular resistance	SHR vs WKY: ↑ Renal vascular resistance WIS = WKY	WIS = WKY
Boylan, Liew and Feig (1991)	USA	NI	6 - 21 weeks	University of Connecticut School of Medicine, Farmington, USA	NI	SBP Method was not indicated show only a graph	erythroid cell volume number regulate the hematocrit erythroid cell count mean cell volume	WIS vs. WKY: ↑ SBP WIS, WKY and SHR: ↑ Progressive increased of Erythroid cell count 21 weeks: SHR: ↑ Erythroid cell count 13 weeks: SHR: ↓ Mean cell volume WIS = WKY	WIS = WKY

Schiffirin et al. (1992)	Canada	NI	4, 7, 8, 12 and 16 weeks	<p>WIS- Charles River, St Constant, Quebec, Canada WKY and SHR- Taconic Farms, Germantown, New York, USA</p>	<p>4 weeks: WIS: 82 ± 2mmHg WKY: 86 ± 2mmHg SHR: 84 ± 2mmHg 8 weeks: WIS: 107 ± 2mmHg WKY: 102 ± 2mmHg SHR: 120 ± 2mmHg 12 weeks: WIS: 105 ± 2mmHg WKY: 109 ± 2mmHg SHR: 147 ± 2mmHg 16 weeks: WIS: 108 ± 1mmHg WKY: 102 ± 2mmHg SHR: 159 ± 2mmHg</p>	<p>SBP were estimated using the tail-cuff occlusion and plethysmography method 4 weeks: WIS: WKY: SHR: 7 weeks: WIS: WKY: SHR: 8 weeks: WIS: WKY: SHR: 12 weeks: WIS: WKY: SHR: 16 weeks: WIS: WKY: SHR:</p>	<p>Plasma ANF concentration Relaxation of blood vessels induced by ANF</p>	<p>Plasma ANF concentration 8 weeks: ↑ SHR vs. WKY 12 and 16 weeks: ↑ WIS Relaxation of blood vessels induced by ANF 4, 8 and 12 weeks ↓ SHR vs. WKY WIS = WKY</p>	WIS = WKY
--------------------------	--------	----	--------------------------	---	--	--	---	--	-----------

Saltzman, Delano and Schmid-Schönbein (1992)	USA	NI	15 - 16 weeks	Charles-River Breeding Laboratories, Wilmington massachusetts- USA	NI	Direct registration of MAP from catheter in femoral artery WIS: 118 ± 8 mmHg WKY: 120 ± 9 mmHg SHR: 160 ± 8 mmHg	Adrenergic Innervation of Arterioles in spinotrapezius muscle	SHR vs. WKY: ↑ Length per area (proximal supply artery, arcade arteriole, thoradorsal artery) SHR vs. WIS: ↑ Length per area (,thoradorsal artery) WIS = WKY	WIS = WKY
Tabrizchi and Triggle (1992)	Canada	Male	12 - 13 weeks	NI	NI	Direct registration of SBP from catheter in iliac artery WIS: 125 ± 3 mmHg WKY: 112 ± 2 mmHg SHR: 181 ± 6 mmHg	vascular sensitivity to L-arginine derived NO Response to L-arginine inhibitor	WIS, SHR and WKY: ↑ Blood pressure after L-arginine inhibitor action WKY and SHR vs. WIS: ↓ Sustained blood pressure after L-arginine infusion	WKY better control
Feres et al. (1992)	Brazil	NI	20 weeks	NI	WIS: 198 ± 3 g WKY: 220 ± 7 g SHR: 200 ± 5 g	SBP were estimated using the tail-cuff occlusion and plethysmography method Basal values are not show	Effect of vitamin D3 on duodenum smooth muscle relaxation Contraction of VSMC after bradykinin action	SHR: ↑ VSMC contraction after bradykinin action D3 vitamin supplementation: SHR: ↑ Relaxation of VSMC WIS = WKY	WIS = WKY
Astarié et al. (1992)	France	NI	4 days	Le Genest-Saint-Isle, France	NI	NI	pH in cardiomyocytes Heart/weight ratio	SHR: ↑ Heart/weight ratio ↑ pH after contractile stimulus WIS = WKY	WIS = WKY

Magee and Schofield (1992)	USA	NI	16 - 19 weeks	Harlan Sprague Dawley, Indianapolis- USA	NI	NI	Simpathetic ganglionic transimtion	SHR: ↑ sympathetic output post-ganglia WIS = W KY	WIS = WKY
Mamuya, Chobabnan and Brecher (1992)	USA	Male	6 weeks 10 weeks 24 weeks 40 weeks	Charles-River Breeding Laboratories, Burlington, Massachusetts, USA Taconic Farms, Germantown, New York- USA	NI	SBP were estimated using the tail-cuff occlusion and a photoelectric cell detector method 6 weeks NI 10 weeks WIS: 108 ± 4 mmHg WKY: NI SHR: 165 ± 5 mmHg 24 weeks WIS: NI WKY: 113 ± 6 mmHg SHR: 177 ± 9 mmHg 40 weeks WIS: 109 ± 6 mmHg WKY: 136 ± 12 mmHg SHR: 185 ± 12 mmHg	Age-Related Changes in fibronectin Expression	WIS and WKY vs. SHR: ↓ Fibronectin with aging WIS = WKY	WIS = WKY
Tremblay and Hamet (1993)	Canada	Male	NI	Taconic Farms, Germantown, New York- USA Charles River, St-Constant, Quebec, Canada Harlan Sprague Dawley, Indianapolis, USA	NI	NI	cGMP production after ANP incubation Genetic heterogeneity of differences commercial sources Guanylate Cyclase Activity	SHR ↑ cGMP production after ANP incubation ↑ Genetic heterogeneity of differentes commercial sources ↑ Guanylate Cyclase Activity WIS = WKY	WIS = WKY

Turrin, Santos and Veiga (1993)	Brazil	Femele	11 - 13 weeks	Paulist school of medicine, São Paulo, Brazil	180 - 210g	SBP were estimated using the tail-cuff occlusion and plethysmography method WIS and WKY: 90 - 120mmHg SHR: 150 - 200mmHg	Lung capacity of ANP generating Plasma ANP	WKY vs. WIS: ↑ Lung ANP SHR vs. WIS: ↑ Plasma ANP	WIS better control
Van Liew, Zamlauski-Tucker and Feld (1993)	USA	Male	WIS- 4 months WKY- 3 months SHR- 17 months	WIS- Rockland, Gilbertsville, Pennsylvania-USA WKY and SHR- Harlan Sprague Dawley, Indianapolis- USA	NI	NI	endogenous creatinine chromagen clearances glomerular filtration rate	WIS = WKY = SHR	WIS = WKY
Klee et al. (1993)	USA	NI	16 - 18 weeks	Mollegaard, Skensved, Denmark,	330 - 380g	DBP were estimated using the tail-cuff occlusion and plethysmography method WIS: 92 ± 8 mmHg WKY: 83 ± 7 mmHg SHR: 117 ± 5 mmHg	Arterial platelet count	SHR: ↓ Arterial platelet count WIS = WKY	WIS = WKY
Sagvolden, Pettersen and Larsen (1993)	Norway	Male	NI	Mollegaard, Skensved, Denmark,	NI	NI	Activity pattern Latency time response	SHR: ↑ Activity ↑ Latency time response WIS = WKY	WIS = WKY
Huang and Koller (1993)	USA	Male	12 weeks	NI	NI	SBP were estimated using the tail-cuff occlusion and plethysmography method WIS: 103.9 ± 3.0 mmHg WKY: 119.1 ± 7.8 mmHg SHR: 194.9 ± 3.0 mmHg	Myogenic Arteriolar Constriction	SHR: ↓ Diameter arterioles ↑ Contractile arterioles WIS = WKY	WIS = WKY

Brooksby, Levi e Jones (1993)	England	Male	16 weeks	WIS- University of Bristol, University Walk, Bristol- England WKY and SHR- Charles River Breeding Laboratories, Margate, USA	NI	NI	contractility and morphology of cardiomyocytes	SHR: ↑ Large cardiomyocyte ↑ amplitude of the Cai transient ↑ prolongation of the action potential ↑ greater myofilament sensitivity to calcium WIS = WKY	WIS = WKY
Magnusson and Meyerson (1993)	Sweden	Male	18 - 19 weeks	NI	NI	NI	Basal estimated vasopressin release	SHR: ↑ Basal vasopressin release ↑ Stimulated release of vasopressin WIS = WKY	WIS = WKY
McLellan et al. (1993)	Escotland	NI	11 weeks	Charles River Breeding Laboratories, Margate- USA	WIS: 288.1 ± 3.4g WKY: 255.3 ± 3.5g SHR: 238.3 ± 6.4g	SBP were estimated using the tail-cuff occlusion and plethysmography method WIS: 155.3 ± 3.8 mmHg WKY: 142.2 ± 3.2 mmHg SHR: 212.9 ± 3.5 mmHg	Plasma membrana resposiviness to isoproterenol	SHR vs. WKY: ↓ Plasma membrana resposiviness to isoproterenol WIS = WKY	WIS = WKY
Morano et al. (1993)	Germany	NI	NI	WIS and WKY- NI SHR- Savo-Ivanovas, Kiss Leg, Germany	WIS: 261 ± 11g WKY: 186 ± 3g SHR: 250 ± 4g	SBP were estimated using the tail-cuff occlusion and plethysmography method WIS: 96.4 ± 4 mmHg WKY: 117.9 ± 2 mmHg SHR: 172.9 ± 4 mmHg	Myosin heavy chain expression in left ventricle	SHR: ↑ Heart weight ↓ α-MHC ↓ Adenylate cyclase WIS = WKY	WIS = WKY
Perez, Petroff and Mattiazzi (1993)	Argentina	Male	6 months	WIS- NI WKY and SHR- Charles-River Breeding Laboratories, Wilmington massachusett- USA	WIS: 332.19 ± 10.53g WKY: 292.79 ± 6.33g SHR: 268.91 ± 3.76g	SBP were estimated using the tail-cuff occlusion and plethysmography method WIS: 126.25 ± 2.28 mmHg WKY: 129.43 ± 1.8 mmHg SHR: 194.19 ± 3.69 mmHg	rest-dependent changes in contractile parameters of heart excitation- contraction coupling of the myocardium.	SHR: ↓ rested-state contractions ↓ rested potentiation ↑ Heart/body weight ratio WIS = WKY	WIS = WKY

Touyz, Tolloczko and Schiffrin (1994)	Canada	Male	3, 9 and 17 weeks	WIS- Charles River, St-Constant, Quebec, Canada WKY and SHR- Taconic Farms, Germantown, New York- USA	<p>3 weeks WIS: $57 \pm 7g$ WKY: $74 \pm 6g$ SHR: $29 \pm 4g$</p> <p>9 weeks WIS: $299 \pm 12g$ WKY: $273 \pm 24g$ SHR: $215 \pm 4g$</p> <p>17 weeks WIS: $505 \pm 22g$ WKY: $470 \pm 17g$ SHR: $326 \pm 10g$</p>	<p>SBP were estimated using the tail-cuff occlusion and a photoelectric cell detector</p> <p>3 weeks WIS: $102 \pm 6mmHg$ WKY: $102 \pm 7mmHg$ SHR: $123 \pm 9mmHg$</p> <p>9 weeks WIS: $112 \pm 7mmHg$ WKY: $107 \pm 8mmHg$ SHR: $154 \pm 15 mmHg$</p> <p>17 weeks WIS: $121 \pm 8 mmHg$ WKY: $108 \pm 16mmHg$ SHR: $204 \pm 12mmHg$</p>	Effect of ANG-2 and ET-1 on calcium response to mesenteric VSMC	<p>3 weeks SHR: ↑ Changes induced by ANG-2</p> <p>9 weeks SHR: ↑ Basal cytosolic free calcium concentration</p> <p>17 weeks SHR: ↑ Changes induced by ANG-2 ↑ ET-1 stimulated cytosolic free calcium concentration</p> <p>WIS = WKY</p>	WIS = WKY
Magee and Schofield (1994)	USA	NI	16 - 19 weeks	NI	NI	<p>SBP were estimated using the tail-cuff occlusion and plethysmography method</p> <p>WIS and WKY < $120mmHg$ SHR: > $170mmHg$</p>	changes in ganglionic transmission	<p>SHR: ↑ Excitatory postsynaptic potential</p> <p>↑ Supramaximal stimuli ↑ increased release of transmitter from preganglionic neurons</p> <p>WIS = WKY</p>	WIS = WKY

Silva et al. (1994)	Brazil	Femele	20 - 30 weeks	WIS- Paulist school of medicine, São Paulo, Brazil WKY and SHR- National Institutes of Health, Bethesda, Maryland, USA	WIS: 190 - 215g WKY: 210 - 230g SHR: 170 - 190g	NI	Celular Na ⁺ content cell membrane potential intracellular potassium activity intracellular sodium activity Ca ²⁺ uptake Tension measurements in response to K ⁺	SHR: ↑ K ⁺ activity ↓ Na ⁺ activity WIS vs. WKY and SHR: ↑ contractile responses to K ⁺ ↓ cell membrane potentia ↑ Ca ²⁺ uptake WKY vs. SHR: ↓ cell membrane potentia	WIS better control
David-Dufilho et al (1994)	France	Male	12 - 14 weeks	NI	WIS: 293 ± 8g WKY: 296 ± 5g SHR: 281 ± 5g	Direct registration of SBP from catheter in aortic artery WIS: 139 ± 4mmHg WKY: 137 ± 3mmHg SHR: 184 ± 3mmHg	corpuscular hemoglobin concentration Ca ²⁺ concentration Ca ²⁺ uptake	SHR: ↑ Ca ²⁺ concentration	WIS = WKY
Rowland, Melvin and Smith (1995)	USA	NI	2 months	WIS- Charles River Breeding Laboratories WKY and SHR- Harlan Sprague Dawley, Indianapolis- USA	NI	NI	Fos-like immunoreactivity after Ang-2 infusion in brain number of FLI cells	SHR: ↑ number of FLI cells n hypothalamic nucleus and supraoptic nucleus WIS: ↑ Fos-like immunoreactivity after Ang-2 infusion in hypothalamic nucleus and supraoptic nucleus WIS = WKY (subfornical organ and postrema/medial nucleus of the solitary tract)	Not conclusive
Dumont and Lamaire (1995)	Canada	NI	4, 8 and 16 weeks	Charles River, St-Constant, Quebec, Canada	NI	NI	Norepinephrine uptake after Dyn-A stimulus	8 weeks: SHR: ↓ Norepinephrine uptake after Dyn-A stimulus WIS = WKY	WIS = WKY

Grisk et al. (1995)	Germany	Male	19 - 24 weeks	Charles River Wiga GmbH, Sulzfeld, Germany	WIS: 521 ± 8g WKY: 334 ± 12g SHR: 359 ± 8g	MAP were estimated using the tail-cuff occlusion and plethysmography method WIS: 105 ± 3 mmHg WKY: 72 ± 4 mmHg SHR: 140 ± 8 mmHg	breathing regulation arterial chemoreceptor reflex function	SHR: ↓ length of the inspiratory time WIS: ↓ Minute ventilation ↓ Inspiratory flow WKY vs. SHR: ↑ Breathing rate ↓ Tidal volume	WKY better control
Bian, Richard and Bukoski (1995)	USA	Male	12 - 15 weeks	Charles-River Breeding Laboratories, Wilmington massachusetts- USA	WIS: WKY: SHR:	SBP was estimated using the indirect pneumatic tail-cuff technique WIS: 126 ± 2.3 mmHg WKY: 117 ± 1.4 mmHg SHR: 157 ± 1.7 mmHg	Vessels measurements	SHR: ↑ saturating Ca ²⁺ WIS vs. WKY: ↑ wall-to-lumen ratio ↑ wall-lumen ratio	WKY better control
Touyz, Tolloczko and Schiffrin (1995)	Canada	NI	3, 9 and 17 weeks	WIS- Charles River. St. Constant, Quebec, Canada WKY and SHR- Taconic Farms Inc. Germantown, New York- USA	3 weeks: WIS: 58 ± 1g WKY: 78 ± 0.8g SHR: 37 ± 0.8g 9 weeks: WIS: 300 ± 4g WKY: 277 ± 5g SHR: 221 ± 2g 17 weeks: WIS: 480 ± 3g WKY: 497 ± 6g SHR: 329 ± 2g	SBP were estimated using the tail-cuff occlusion and plethysmography method 3 weeks: WIS: 103 ± 2 mmHg WKY: 101 ± 2 mmHg SHR: 123 ± 3 mmHg 9 weeks: WIS: 110 ± 2 mmHg WKY: 106 ± 3 mmHg SHR: 221 ± 2 mmHg 17 weeks: WIS: 107 ± 2 mmHg WKY: 116 ± 3 mmHg SHR: 204 ± 3 mmHg	Ca ²⁺ in VSMC Ang-2 induced Ca ²⁺ concentration Insulin+Ang-2 induced Ca ²⁺ concentration	9 weeks: SHR: ↑ Ang-2 induced Ca ²⁺ concentration ↑ Insulin+Ang-2 induced Ca ²⁺ concentration 17 weeks: SHR: ↑ Ang-2 induced Ca ²⁺ concentration ↑ Insulin+Ang-2 induced Ca ²⁺ concentration WIS = WKY	WIS = WKY
Feng and Arendshorst (1996)	USA	NI	7 - 9 weeks	Chapel Hill Breeding Colonies, North Carolina- USA	NI	Direct registration of SBP from catheter in carotid aortic artery WIS: NI WKY: 124 ± 11 mmHg SHR: 147 ± 7 mmHg	Vascular reactivity to vasopressin Renal vascular resistance	SHR: ↑ Renal vasoconstriction after vasopressin infusion ↑ Vascular reactivity WIS = WKY	WIS = WKY

Findlay (1996)	England	Male	NI	NI	NI	NI	Effect of losartan and ANG-2 blocker on water and NaCl intake induced by sodium depletion	SHR: ↑ intakes of saline and water after drugs stimulus ↑ reduced intakes of saline and water after drugs stimulus WIS = WKY	WIS = WKY
Blume et al. (1997)	Germany	NI	12 weeks	WIS- Dr Karl Thomae GmbH-Germany WKY and SHR- Mollegaard Breeding Farm, Skensved, Denmark	WIS: 280 - 300g WKY: 280 - 300g SHR: 240 260g	Direct registration of SBP from catheter in carotid aortic artery WIS: 90±8 mmHg WKY: 93±7 mmHg SHR: 165±11 mmHg	Ang II-induced expression of c-Fos c-Jun expression	SHR: ↑ Ang II-induced expression of c-Fos ↑ c-Jun expression WIS = WKY	WIS = WKY
Gattu et al. (1997)	USA	Male	12 weeks	WIS- Harlan Sprague Dawley, Indianapolis- USA WKY and SHR- Taconic Farms, Germantown, New York- USA	NI	SBP Method was not indicating WIS: 127 ± 9.04 mmHg WKY: 129 ± 6.25 mmHg SHR: 192 ± 5.2 mmHg	learning abilities memory abilities nicotinic receptors expression density of brain nicotinic receptors	SHR: ↓ learning abilities ↓ memory abilities SHR vs. WIS: ↓ density of brain nicotinic receptors SHR vs. WKY: ↓ nicotinic receptors expression WIS = WKY	WIS = WKY
Touyz and Schiffrin (1997)	Canada	Male	17 weeks	WIS- Charles River, St Constant, Quebec, Canada WKY and SHR- Taconic Farms, Germantown, New York, USA	WIS: 444 ± 2.5g WKY: 478 ± 7.8g SHR: 318 ± 2.3g	SBP were estimated using the tail-cuff occlusion and photo-electric pulse sensor method WIS: 106 ± 3.6 mmHg WKY: 111 ± 3.1 mmHg SHR: 194 ± 2.5 mmHg	Ca ²⁺ concentration in mesenteric arteries Ca ²⁺ concentration in mesenteric arteries after Ang-2 stimulated	SHR: ↑ Ca ²⁺ concentration WIS, WKY and SHR: ↑ Ca ²⁺ concentration after Ang-2 estimated WIS = WKY	WIS = WKY

Preuss et al. (1998)	USA	Male	6 weeks	Taconic Farms, Germantown, New York- USA	Show only a graph		SBP were estimated using the tail-cuff occlusion and plethysmography method Show only a graph	high sucrose ingestion on SBP	WIS, WKY and SHR: ↑ SBP after high sucrose ingestion WIS = WKY	WIS = WKY
Feres et al. (1988)	Brazil	Femele	20 - 30 weeks	WIS- Wistar Institute, Philadelphia, USA WKY and SHR- National Institutes of Health, Bethesda, USA	200 - 220g	NI		RMP of arteries	SHR: ↓ Sensitivity or density of α 2-adrenoreceptors less negative membrane potential. WIS=WKY	WIS = WKY
Tanigawa, Inoue and Tamura (1999)	Japan	Male	10 weeks	WIS- Shizuoka Laboratory Center, Hamamatsu, Japan WKY and SHR- Charles River Laboratories, Atsugi, Japan	WIS: $312 \pm 3g$ WKY: $293 \pm 3g$ SHR: $255 \pm 3g$		SBP were estimated using the tail-cuff occlusion and plethysmography method WIS: NI WKY: 163 ± 4 mmHg SHR: 220 ± 7 mmHg	insulin secretory activity of pancreas	SHR: ↑ Nonfasting plasma glucose ↑ Insulin levels ↑ insulin secretory activity of pancreas WIS = WKY	WIS = WKY
Kitami et al. (1999)	Japan	NI	12 weeks	Charles-River Breeding Laboratories, Wilmington massachusetts- USA	NI	NI		VSMC hypertrophy	SHR: ↑ PDGR- α R expression WKY and SHR vs. WIS: ↑ C/EBP probe expression	WIS better control
Dalle Lucca et al. (2000)	Brazil	Male	NI	Wistar Institute, Philadelphia- USA	300 - 30g		MAP were estimated using the tail-cuff occlusion and plethysmography method WIS: 114 ± 24 mmHg WKY: 128 ± 24 mmHg SHR: 194 ± 18 mmHg	morphometric analysis of injured arteries	SHR: ↑ medial hypertrophy ↑ neointima formation WIS = WKY	WIS = WKY

Gros et al. (2000)	USA	Male	10 weeks	Harlan Sprague Dawley, Indianapolis- USA	100 - 350g	MAP were estimated using the tail-cuff occlusion and plethysmography method WIS and WKY: <120mmHg SHR: >125mmHg	isoproterenol relaxation	SHR: ↑ isoproterenol relaxation WIS = WKY	WIS = WKY
Hancock and Lindsay (2000)	USA	Male	NI	Harlan Sprague Dawley, Indianapolis- USA	300 - 400g	BP were estimated using the tail-cuff occlusion and plethysmography method WIS: 116 ± 10 mmHg WKY: 92 ± 15 mmHg SHR: 154 ± 6 mmHg	ganglionic responses after Intravenous injection of substance P	SHR: ↑ Renal nerve firing ↑ Blood pressure increased WIS = WKY	WIS = WKY
Kawasaki et al. (2000)	Japan	Male	15 weeks	Charles River Laboratories, Shizuoka, Japan	NI	Direct registration of MAP from catheter in carotid aortic artery WIS: 95.5 ± 2.7 mmHg WKY: 97.8 ± 1.8 mmHg SHR: 187.7 ± 1.5 mmHg	Baroreflex function after Spinal Cord Stimulation	SHR: ↑ CGRP mRNA Level WIS and WKY: ↑ BP decreased WIS = WKY	WIS = WKY
Casellas et al. (2000)	USA	Male	12 weeks	Iffa Credo, Lyon, France	WIS: 424 ± 9g WKY: 266 ± 6g SHR: 329 ± 7g	NI	adrenergic innervation along preglomerular vascular	WIS = WKY = SHR	WIS = WKY
Sato et al. (2001)	Brazil	Male	14 - 16 weeks	NI	250 - 300g	Direct registration of MAP from catheter in femoral artery Show only a graph	effects of acute of lesion commissural nucleus of the solitary tract on basal mean arterial pressure and	after lesion commissural nucleus of the solitary tract SHR: ↓ SBP ↓ chemoreceptor reflex ↑ Baroreceptor Reflex	WIS = WKY

							the baroreceptor and chemoreceptor reflex	WIS and WKY: ↓ bradycardic responses WIS = WKY	
Ibarra, López-Guerrero and Villalobos-Molina (2001)	Mexico	Male	6 months	NI	NI	SBP were estimated using the tail-cuff occlusion and plethysmography method WIS: 125 ± 20 mmHg WKY: 135 ± 10 mmHg SHR: 192 ± 10 mmHg	Contraction of aortic and tail arterial rings	SHR: ↑ Contraction induced by norepinephrine SHR and WKY vs. WIS: ↑ Contraction induced by chloroethylclonidine	WIS better control
Fox et al. (2002)	USA	Male	20 - 24 days	Harlan Sprague Dawley, Indianapolis- USA	35 - 50g	NI	Pups behavior	SHR: ↑ Impusivity rate ↓ Rate of learning WIS = WKY	WIS = WKY
Borges et al. (2002)	Brazil	Femele	20 - 30 weeks	WIS- Wistar Institute, Philadelphia- USA WKY and SHR- National Institutes of Health, Bethesda, Maryland, USA	200 - 220 g	SBP were estimated using the tail-cuff occlusion and plethysmography method WIS: 130 ± 6 mmHg WKY: 135 ± 7 mmHg SHR: 160 ± 5 mmHg	mechanical responses after bradykinin stimulus in VSMC	WIS vs. WKY: ↑ Concentration /response curves	WIS better control

Aiello et al. (2004)	Argentina	Male	4 - 5 months	WIS- school of medical sciences, Argentina WKY and SHR- Charles-River Breeding Laboratories, Wilmington massachusetts- USA	WIS: 324.9 ± 9.2g WKY: 305.3 ± 5.1g SHR: 314.5 ± 4.5g	SBP were estimated using the tail-cuff occlusion and plethysmography method WIS: 118.5 ± 1.0 mmHg WKY: 119.8 ± 1.6 mmHg SHR: 175.8 ± 1.8 mmHg	Myocardial hypertrophy	SHR: ↑ LVM ↑ LVM/BM ↓fractional shortening WKY vs. WIS: ↑ LVM ↑ LVM/BM ↓fractional shortening SHR and WKY vs. WIS; ↑ CSA	WIS better control
Wickens et al. (2004)	New Zeland	NI	30 - 32 weeks	WIS- University of Otago WKY and SHR-Animal Resources Centre, Western- Australia	NI	SBP were estimated using the tail-cuff occlusion and plethysmography method Show only a graph	behaviour disorders	SHR: ↑ Lever presser ↑ abnormal sensitivity WIS = WKY	WIS = WKY
Shcherbin and Tsyrilin (2004)	Russia	Male	19 - 24 weeks	NI	280 - 310g	Direct registration of MAP from catheter in carotid femoral artery WIS: 117 ± 7.1 mmHg WKY: 123 ± 2.1 mmHg SHR: 164 ± 5.7 mmHg	Somatosympathetic Reflex	SHR: ↑ durations and amplitudes of sympathetic reflex discharges WIS = WKY	WIS = WKY
Bueno et al. (2004)	Brazil	NI	12 weeks	NI	NI	SBP were estimated using the tail-cuff occlusion and plethysmography method WIS:108.6 ± 8.74 mmHg WKY: NI SHR: 150 - 180 mmHg	Expression of 90-kd isoform ACE	SHR: ↑ Renal artery 90-kd isoform ACE expression WIS = WKY	WIS = WKY
Van den Bergh et al. (2006)	Netherlands	Male and famale	30 - 100 days.	Harlan Laboratories, Netherlands	NI	NI	activity, attention and impulse control	SHR vs. WKY: ↑ Hyperactivity ↑ active in the open field SHR vs. WIS: ↓ Impulsive WIS = WKY	WIS = WKY

Kubo and Hagiwara (2006)	Japan	Male	15 - 16 weeks	WIS- NI WKY and SHR- Disease Model Cooperative Research Association, Kyoto, Japan	WIS: WKY: SHR:	SBP were estimated using the tail-cuff occlusion and plethysmography method WIS: 101 ± 2 mmHg WKY: 114 ± 2 mmHg SHR: 169 ± 2 mmHg	intracerebroventricular injection of hypertonic saline on the neural activity	SHR: ↑ firing rate of AHA ANG-2 sensitive neurons ↓ threshold sodium concentration WIS = WKY	WIS = WKY
Sakamoto et al. (2006)	Japan	Male	8, 12, 16 and 20 weeks	NI	NI	NI	sensitivity to glibenclamide (antidiabetic agent)	Before glibenclamide treatment: SHR and WKY: ↑ Plasma glucose levels 12 - 20 weeks WKY: ↑ Resistance to glibenclamide administration SHR: ↑ number of choices of the large reward ↓ number of choices of the large-but-delayed reward ↑ Impulsivity WIS = WKY	WIS better control
Bizot et al. (2007)	France	Male	70 -95 days	Centre d'Elevage René Janvier, France	WIS: 296 ± 7g WKY: 248 ± 7g SHR: 201 ± 2g	NI	impulsive behaviour	SHR: ↑ number of choices of the large reward ↓ number of choices of the large-but-delayed reward ↑ Impulsivity WIS = WKY	WIS = WKY
Orduna, Hong and Bouzas (2007)	Mexico	Male	60 days	WIS- Harlan, Mexico City, Mexico WKY and SHR- Charles-River Breeding Laboratories, Wilmington massachusetts- USA	190 - 250g	MAP were estimated using the tail-cuff occlusion and plethysmography method WIS: 102 ± 4.51 mmHg WKY: 124 ± 5.26 mmHg SHR: 175 ± 8.33 mmHg	timing behavior	WIS = WKY = SHR	WIS = WKY

Wheal et al. (2007)	England	Male	SHR: ~20 weeks	WIS and SHR- Charles River Breeding Laboratories, United Kingdom WKY- Harlan Laboratories, United Kingdom	WIS: 350 - 450g WKY and SHR: ~300g	Direct registration of MAP from catheter in tail artery WIS: 111 ± 2 mmHg WKY: 120 ± 3 mmHg SHR: 176 ± 5mmHg	Hemodynamics effects of cannabinoids	Before drugs administration SHR: ↑ SBP ↓ Vascular conductance anandamide effect SHR: ↑ Sustained bradycardia ↓ SBP ↑ Renal and mesenteric vasoconstriction AM 251 effect SHR: ↑ SBP WIN 55212-2 effect ↑ SBP ↓ Vascular conductance WIS = WKY	WIS = WKY
Ribeiro, Afonso and Macedo (2007)	Portugal	Male	9 weeks	Charles River Breeding Laboratories, Spain	250 - 300g	Direct registration of SBP from catheter in femoral artery WIS: 118.1 ± 3.7 mmHg WKY: 106.7 ± 2.5 mmHg SHR: 159.2 ± 3.7mmHg	insulin action	SHR vs. WIS: ↑ Insulin resistant ↓ Insulin action in hepatic parasympathetic nerves ↓ insulin sensitivity indexes WKY vs. WIS: ↓ Insulin action in hepatic parasympathetic nerves ↓ insulin sensitivity indexes	WIS better control
Orduna et al. (2008)	Mexico	Male	60 days	WIS- Harlan, Mexico City, Mexico WKY and SHR- Charles-River Breeding Laboratories, Wilmington massachusetts- USA	WIS: 281.3g WKY: 253.3g SHR: 228g	MAP were estimated using the tail-cuff occlusion and plethysmography method WIS: 108.33 ± 2.98 mmHg WKY: 109.17 ± 2.57 mmHg SHR: 143.92 ± 9.95 mmHg	timing behavior	SHR: ↑ peak response rate WIS = WKY	WIS = WKY

Ordunas, Valencia-Torres and Bouzas (2009)	Mexico	Male	90 days	WIS- Harlan, Mexico City, Mexico WKY and SHR- Charles-River Breeding Laboratories, Wilmington massachusetts- USA	230 - 345g	NI	Timing behavior	SHR ↓ reinforcers earned ↑ percentage of efficiency ↓ response threshold parameter SHR vs. WKY: ↑ burst ratio WIS = WKY	WIS = WKY
Sandow, Gzik and Lee (2009)	Canada	Male	NI	WIS- NI SHR and WKY- University of New South Wales, UNSW, Sidney- Austrália	NI	NI	Arterial internal elastic lamina hole density and size	WKY vs. WIS: ↑ Arterial internal elastic lamina hole ↓ rat superior mesenteric	Not conclusive
Oliveira et al. (2009)	Brazil	Male	12 - 14 weeks	Wistar Institute, Philadelphia- USA	290 - 320g	NI	lipid reconstructs and lipid composition of VSMC	SHR: ↓ Palmitic acid ↑ arachidonic acid WIS and WIS vs. SHR: ↑ Cholesterol levels WIS = WKY	WIS = WKY
Percy et al. (2009)	Australia	Male	3 months and 21 - 24 months	NI	3 months WIS: 360 ± 16g WKY: 257 ± 56g SHR: 262 ± 17g 21 - 24 months: WIS: 689 ± 53g WKY: 444 ± 32g SHR: 392 ± 32g	SBP were estimated using the tail-cuff occlusion and plethysmography method 3 months WIS: 118 ± 3 mmHg WKY: 133 ± 2 mmHg SHR: 205 ± 4 mmHg 21 - 24 months: WIS: 138 ± 4 mmHg WKY: 148 ± 7 mmHg SHR: 200 ± 6 mmHg	energy metabolism and oxidant handling mechanisms in chronic kidney disease	21 - 24 months: WIS: ↑Visceral and perirenal adipose tissue ↑ Plasmatic lactate dehydrogenase ↑ fibrotic index WIS and SHR vs. WKY: ↑ Apoptosis in tubular epithelium	WKY better control

Tran, DeLano and Schimid-Schönbein (2010)	USA	Male	12 - 18 weeks	Charles-River Breeding Laboratories, Wilmington massachusetts- USA	280 - 350g	Direct registration of MAP from catheter in femoral artery WIS: NI WKY: 113 ± 4 mmHg SHR: 164 ± 6 mmHg	Matrix MMP Activity	SHR: ↑ Protease activity ↑ plasma activity of MMP-2, MMP-9, and MMP-7 SHR vs. WIS: ↑ plasma activity of MMP-3 SHR vs. WKY: ↓ plasma activity of MMP-14 WIS = WKY	WIS = WKY
Dommett and Rostron (2011)	England	Male	NI	WIS and WKY- NI SHR-Charles River Wiga GmbH, Sulzfeld, Germany	NI	NI	air righting reflexes	SHR: ↑ faster movement ↓ height-dependent modulation WIS and WKY vs. SHR: ↑ tendency to use a longitudinal movement WIS = WKY	WIS = WKY
Ibías and Péllon (2011)	Spain	Male	12 weeks	Charles River Laboratories, Lyon, France	WIS: 353g WKY: 306g SHR: 277g	NI	levels of acquisition of schedule-induced polydipsia	SHR: ↑ drinking ↑ greater cognitive impulsivity WKY: ↓ licks and drank per minute WIS vs. SHR: ↑ FT 9-s and FT 15-s schedules	Not conclusive

Langen and Dost (2011)	Germany	Male	7–8 weeks	Charles River Wiga GmbH, Sulzfeld, Germany	150–180 g	NI	dopamine of behavior	SHR: ↑ Activity in open-field arena after 24h ↑ long-term memory SHR and WIS vs. WKY: ↑ Activity in open-field arena for the first time ↓ anxiety-related behaviour WIS and WKY vs. SHR: ↑ habituate to a novel environment Dopamine effect: WKY: ↓ Activity SHR: ↑ Activity	Not conclusive
Castelló-Ruiz et al. (2011)	Spain	Male	15 - 17 weeks	NI	NI	Direct registration of MAP from catheter in femoral artery WIS: 113 ± 4 mmHg WKY: 111 ± 6 mmHg SHR: 140 ± 7 mmHg	neuroprotective effect of nutritional and pharmacological soy-derived isoflavones against stroke	WKY vs. WIS and SHR: ↓ Cerebral infarct volume Nutritional and pharmacological effects: WIS: ↓ Cerebral infarct volume	WKY better control
Herman et al. (2011)	USA	Male and female	WIS- 8 - 10 weeks WKY and SHR- 12 weeks	Taconic Farms, Germantown, New York- USA Harlan Industries, Indianapolis- USA	NI	NI	Baseline Serum Cardiac Troponin I Concentrations	SHR (male): ↑ Cardiac Troponin I Concentrations Male vs. female (all strains): ↑ Cardiac Troponin I Concentrations WIS = WKY	WIS = WKY

Sanada et al. (2011)	Brazil	Femele	20 weeks	animal care facility of the Department of Neurology, School of Medicine of Ribeirao Preto	Show only a graph	SBP were estimated using the tail-cuff occlusion and plethysmography method Show only a graph	Sural nerve morphology	SHR: ↑ Sural nerve diameter ↑ Myelinated area WIS = WKY	WIS = WKY
Harvey et al. (2011)	USA	Male	25 days	Charles-River Breeding Laboratories, Wilmington massachusetts- USA	NI	NI	Methylphenidate Treatment for ADHD	SHR: ↑ deficit in the acquisition of learning Methylphenidate treatment: SHR: ↑ visual discrimination WIS = WKY	WIS = WKY
Hill, Herbst and Sanabria (2012)	USA	Male	24 - 25 days	WIS and SHR- Charles-River Breeding Laboratories, Wilmington massachusetts- USA WKY- Harlan Sprague Dawley, Indianapolis- USA	WIS: 190g WKY: 127g SHR: 118g	NI	hyperactivity behavior	SHR: ↑ Operant hyperactivity WIS = WKY	WIS = WKY
Dommett and Rostron (2013)	England	Male	28 weeks	NI	Show only a graph	NI	Appetitive and consummative responding for liquid sucrose	SHR: ↑ water intake ↓ time to traverse the runway ↑ velocity WKY: ↑ Weight gain WIS = WKY	WIS = WKY
Somkuwar et al. (2013)	USA	Male	25 - 55 days	WIS- Charles River Laboratories, Raleigh, NC WKY and SHR- Charles River Laboratories, Kingston, New York- USA	NI	NI	Methylphenidate Treatment for ADHD	SHR: ↑ Maximum Velocity in medial prefrontal cortex WIS = WKY	WIS = WKY

Somkuwar et al. (2013)	USA	Male	25 days	WIS- Charles River Laboratories, Raleigh, NC WKY and SHR- Charles River Laboratories, Kingston, New York- USA	NI	NI	Atomoxetine Treatment for ADHD	Baseline: SHR: ↑ acquired cocaine self-administration faster ↑ earned cocaine ↑ breakpoints WIS vs. WKY: ↑ earned cocaine ↑ active lever Atomoxetine Treatment: SHR and WKY vs. WIS: ↑ acquired cocaine self-administration faster SHR: ↑ Horizontal activity SHR vs. WIS: ↑ Active Methylphenidate and venlafaxine infusion: SHR: ↓ horizontal activity WIS = WKY	Not conclusive
Umehara et al. (2013)	Japan	Male	4 - 7 weeks	Charles River Laboratories. Yokohama, Japan	NI	NI	Locomotor behavior	SHR vs. WKY: ↑ peak Na excretion ↑ Natriuretic response SHR vs. WIS: ↓ Natriuretic response WIS = WKY	WIS = WKY
Wang, Thonsen and Frøkiær (2013)	Denamark	Male	10 - 11 weeks	Mollegaard Breeding Farm, Skensved, Denmark	200 - 300g	Direct registration of MAP from catheter in femoral artery WIS: 113 ± 4 mmHg WKY: 115 ± 3 mmHg SHR: 148 ± 3 mmHg	Renal responses to acute volume expansion	SHR vs. WKY: ↑ peak Na excretion ↑ Natriuretic response SHR vs. WIS: ↓ Natriuretic response WIS = WKY	WIS = WKY

Harvey et al. (2013)	USA	Male	25 - 28 days	Charles-River Breeding Laboratories, Wilmington massachusetts- USA	NI	NI	Performance on a strategy set shifting task	<p>WKY and SHR vs. WIS: ↓ trials to learn ↓ latencies to reach criterion SHR vs. WIS: ↓ trial omissions</p>	WIS better control
Jordan et al. (2014)	USA	Male	25 - 55 days	Charles-River Breeding Laboratories	NI	NI	Cocaine-seeking behavior	<p>SHR: ↑ cocaine infusions ↑ active lever responses ↑ inactive lever responses ↑ cocaine-seeking responses WIS vs. SHR: ↓ number of sessions WIS = WKY</p>	WIS = WKY
Nam et al. (2014)	USA	Male	6- 7 weeks	Charles River Laboratories, Kingston, New York- USA	<p>WIS: 376.0 ± 9.3g WKY: 254.9 ± 3.8g SHR: 268.8 ± 3.9g</p>	NI	Learned helplessness and social avoidance	<p>WKY vs. WIS and SHR: ↑ spent time in the avoidance zone ↑ adrenal glands weights ↑ behavioral inhibition in anxiogenic environments ↑ immobility levels SHR: ↓ Morris Water Maze ↑ memory and learning deficits = WKY</p>	WKY used as behavior disorder model
Günblatt et al. (2015)	Switzerland	Male and female	12 and 28 weeks	Charles River Laboratories, Kisslegg, Germany	NI	NI	cognitive deficits	<p>WIS</p>	WIS = WKY

Somkuwar, Kantak and Dwoskin (2015)	USA	Male	28 - 91 days	Charles River Laboratories, Raleigh, North Carolina- USA Charles River Laboratories, Kingston, New York- USA	NI	NI	transporter function in orbitofrontal cortex	SHR: ↑ NE uptake WIS = WKY	WIS = WKY
Kodavanti et al. (2015)	USA	Male	10 - 12 weeks	Charles River Laboratories, Raleigh, North Carolina- USA	NI	NI	pulmonary injury and inflammation	SHR: ↑ Protein levels ↑ Inflammataion SHR vs. WKY: ↑ numbers in bronchoalveolar lavage fluid WIS = WKY	WIS = WKY
Íbias, Pellón and Sanabria (2015)	Spain	Male	12 weeks	Charles River Laboratories. Lyon, France	WIS: 359 - 384g WKY: 306 - 361g SHR: 277 - 302g	NI	SIP acquisition	SHR: ↑ Licks/min ↑ drinking episodes ↑ SIP acquisition faster ↑ Operant hyperactivity WIS = WKY	WIS = WKY
Brace et al. (2015)	England	Male	15 - 20 weeks	Harlan Laboratories, Bicester, England	NI	NI	Auditory responses	SHR: ↓ Response to stimulus	WIS = WKY

Íbias, Miguéns and Pellón (2016)	Spain	Male	12 weeks	Charles River Laboratories. Lyon, France	WIS: 359 - 384g WKY: 306 - 361g SHR: 277 - 302g	NI	Effects of dopamine on SIP	intensity latency SHR vs. WKY: ↑ Vertical activity WKY: ↓ moving less WIS = WKY SHR: ↑ Licks/min ↑ drinking episodes d-amphetamine effect: SHR: ↑ Licks methylphenidate effect: SHR: ↑ Licks SHR vs. WIS: ↑ Entires WIS = WKY	↑ onset	WIS = WKY
Jordan et al. (2016)	USA	Male	28 - 77 days	Charles River Laboratories	WIS: 356 ± 11g WKY: 254 ± 5g SHR: 255 ± 5g	NI	d-amphetamine treatment to ADHD acquisition of cocaine selfadministration	SHR: ↑ acquisition of cocaine selfadministration faster ↑ number of cocaine infusions ↑ active lever responses d-amphetamine treatment: SHR: ↓ postacquisition cocaine intake WIS = WKY		WIS = WKY

Jordan et al. (2016)	USA	Male	28 - 77 days	Charles River Laboratories	NI	NI	d-amphetamine treatment to ADHD Pro-cognitive effects cocaine cue reactivity	SHR: ↑ active lever ↑ cocaine infusions ↑ stress vulnerability SHR and WIS vs. WKY: ↓ Trials ↓ Latencies SHR and WKY vs. WIS: ↓ reaction time ↑ reaction time variability d-Amphetamine treatment: SHR: ↓ latency to criterion Response to AT2R antagonist (PD123319): SHR: ↓ MAP increase ↓ splanchnic nerve activity Response to L-glutamate: SHR vs. WKY: ↑ MAP increase ↑ splanchnic nerve activity WIS = WKY	Not conclusive
Kawabe et al. (2016)	USA	Male	14 weeks	Charles-River Breeding Laboratories, Wilmington massachusetts- USA	NI	Direct registration of MAP from catheter in femoral artery WIS: 103.3 ± 2.5 mmHg WKY: 90.3 ± 2.6 mmHg SHR: 147.1 ± 2.8 mmHg	Ang-2 receptor function in the rostral RVLM	SHR: ↓ MAP increase ↓ splanchnic nerve activity Response to L-glutamate: SHR vs. WKY: ↑ MAP increase ↑ splanchnic nerve activity WIS = WKY	WIS = WKY

Somkuwar et al. (2016)	USA	Male	25 - 58 days	WIS- Charles River Laboratories, Raleigh, North Carolina- USA WKY and SHR:- Charles River Laboratories, Kingston, New York- USA	WIS: WKY: SHR:	NI	methylphenidate treatment to impulsivity and hyperactivity in ADHD	SHR: ↓ percent of responses reinforced ↓ efficiency ↑ Impulsivity SHR vs. WKY: ↑ total horizontal beam breaks WKY vs. WIS: ↓ total horizontal beam breaks WKY: ↑ Hypoactive methylphenidate treatment: SHR: ↑ Hyperactivity reduced	WIS better control
Íbias et al. (2017)	Spain	Male	36 weeks	Charles River Laboratories, Lyon, France	WIS: 343 - 368g WKY: 310 - 362g SHR: 299 - 323g	NI	Effect of 6 days of Methylphenidate treatment on SIP	SHR: ↑ licking rates SHR vs. WKY: ↑ Longer dring episode Methylphenidate treatment: WKY: ↓ Drink ↓ SIP WIS: ↓ frequency of licking SHR: ↓ task activity SHR vs. WKY: ↑ reaction time WKY and SHR vs. WIS:	Not conclusive
Rostron et al. (2017)	England	NI	10 weeks	Charles River Laboratories, Kisslegg, Germany	WIS: 204 ± 1.8g WKY: 188 ± 5g SHR: 132 ± 2.5g	NI	learnt behaviour in ADHD	SHR: ↓ task activity SHR vs. WKY: ↑ reaction time WKY and SHR vs. WIS:	Not conclusive

Peña et al. (2017)	South Korea	Male	4 weeks	Charles River Laboratories. Yokohama, Japan	NI	NI	Effects of Methylphenidate and Atomoxetine in impulsive behavior	↑ Weight gain WIS vs. WKY: ↑ incorrect responses ↓ discrimination index SHR and WIS vs. WKY: ↓ choice for the large reward ↑ impulsivity choice SHR vs. WKY: ↑ nonreinforced responding ↑ Impulsive behavior Drugs effects: SHR: ↓ discounting WIS: ↓ delay discounting WKY: ↑ discounting SHR and WIS vs. WKY: ↑ Genes expression in prefrontal cortex	Not conclusive
Rybinikova, Vetrovi and Zenko (2018)	Russia	Male	NI	Pavlov Institute of Physiology, Saint Petersburg- Russia	NI	NI	Behavior, Hormonal Level and Antioxidant Status	WIS: ↑ indices of anxiety ↑ depressive-like behavior SHR and WKY vs. WIS: ↓ indices of anxiety ↓ depressive-like behavior	WKY better control

WIS- Wistar; WKY- Wistar Kyoto; SHR- Spontaneously Hypertensive Rat; LVM- left ventricle mass; g- gram; mmHg- milimeter of mercury; NI- not indicated; SBP- Systolic blood pressure; DBP- Diastolic blood pressure; MAP- mean arterial pressure; LVM/BM: Left ventricular/body mass ratio; ↑- increase than others strains (p<0.05); >- higher; <- lower; STN- Solitary tract nucleus; ACTH- Adrenocorticotrophic hormone; 6-OHDA- 6-hydroxydopamine hydrochloride; 5HT- Serotonin; NE- Norepinephrin; VMSC- vascular muscle smooth cells; K+- potassium; Na+- sodium; RMP- Rest membrane potentials; Ca2+- calcium; AA- arachidonic acid; ANG-2- Angiotensin II; Dyn-A- Dynorphin-A; COX- cytochrome oxidase; PVH- paraventricular nuclei; SON- supraoptic nuclei; ANF- Atrial natriuretic factor; ET-1- Endothelin 1; ET-3- Endothelin 3; NO- Oxid nitric; cGMP- cyclic guanosine monophosphate; ANP- atrial natriuretic peptide; α-MHC- Myosin heavy chain; NaCl- sodium chloride; PDGR-αR- Platelet-derived growth factor-α receptor; C/EBP- CCAAT-enhancer binding proteins; GRK- G-protein– coupled receptor kinase; ACE- Angiotensin-converting enzyme; ADHD- attention deficit hyperactivity disorder; MMP- Metalloproteinase; FTs- fixed time schedules; SIP- schedule-induced polydipsia; AT1Rs- ANG II type 1 receptors; AT2Rs- ANG II type 2 receptors; RVLM- ventrolateral medullary pressor area;

4- Discussion:

Methodology is the theory of organization of a scientific research (35). The planning and application of right methods is critical for scientific researches. This including the selection of adequate experimental models for sample composing in agreement with study objectives. Thus, this work aimed to map studies that used the WIS and WKY strains simultaneously as SHR control, allowing the proper characterization of the available variables of strains.

The epidemiological transition theory explains the transition of mortality causes and diseases incidence along the time (36). The world development leading to life expectation increase and decreased the number of deaths from hunger or infectious diseases (36). However, this change led to the emergence and high worldwide incidence of chronic degenerative diseases- such as the hypertension- which generated great demand for their understanding in the first half of the last century (4, 6, 8). The panel A of fig.1 shows an exponential increase in the number of researches related to hypertension since the 1960s, showing a peak in the 1990s. We have already pointed to a collective effort by researches groups to develop an experimental model that would allow the study of EAH (4, 6, 7, 9), which culminated in the development of SHR by Okamoto in 1963, in Japan (5). Consequently, the availability of a model (SHR) that has been shown to reliably reproduce the characteristics of the disease promote the mass research production about hypertension.

The use of the SHR model to study the effects of hypertension requires an experimental normotensive strain as control and the WKY were pointed as the ideal model, since they are SHR background (5, 10). However, controversial results began to emerge from the analysis of the WKY, which led to questions about its use as control of hypertensive animals, initiating a series of comparative researches and a search for an ideal model for this function. According to our search (fig.2-panel B), Tobia, Lee and Walsh (1974) published the first study using more than one experimental model as SHR control and they investigated the regional blood flow of iliac and mesenteric arteries of WIS, WKY and SHR and found that WIS presented higher total peripheral resistance than WKY, what indicated the later as better control (37). Following, Frohlich and Pfeffer in 1975 also included WIS rats in company with WKY, and they justified the WIS select because they are the initial progenitor of WKY strain (38). This study evaluated the adrenergic mechanism of hypertension and found similar results from normotensive animals (38).

However, many other factors are involved with the onset and development of the disease, which prompted the use of both models as control of SHR in many studies in the years that followed- with peak observed between 1980s and 1990s decades (21, 22, 25, 27-31, 37-187).

Geographic distribution:

We found studies on all continents, which the Americas with ninety-nine studies and Europe with forty-four studies were the continents that contributed most to the characterization of the strains. It is important to highlight the volume of work developed by the United States, which totaled 68 papers. On the other hand, Africa with 1 study and Oceania with 3 studies were the continents with the lowest production. This analysis of geographic distribution points out that the concern as to which model should be used as SHR control was global, which encouraged this methodological organization, including the three strains in all these studies around the world.

Laboratory of supplying animals:

Another important point to be highlighted is the laboratory of origin of the experimental models (Tab.1). The laboratories that most frequently supply animals for the studies were *Charles River* (WIS- 71; WKY- 57; SHR- 60), followed by *Harlan Laboratories* (WIS- 14; WKY- 14; SHR- 14) and *Taconic Farms, Germantown, New York-USA* (WIS - 8; WKY-14; SHR-14). The studies pointed to the animals withdraw from several sites of the *Charles River* and *Harlan laboratories*, while just one for the *Taconic Farms*.

The choice of the laboratory for supplying the animals is important since there are research indicates biological variability in WKY and SHR rats from different laboratories, in which the animals presented different levels of mean arterial pressure (13). Also, the genetic variability of these strains was tested through genomic analysis and were founded differences between WKY of different laboratories and even between animals from the same laboratory (12). Kreutz *et al.* (1997) found that are WKY strain with chromosome 10 distinctions- this was linked to diastolic and systolic blood pressure (188, 189)- and they were named WKY0 and WKY1, and the WKY1 had higher baseline arterial pressure values (190). Langen and Dost (2011) found a behavior and genetic deviation between *Harlan* and *Charles River* laboratories and considerate that they are different substrains (30). A group of United States develop a serie of researches that confirm the great genetic

variability between WKY from different laboratories and that WKY from *Charles River* are good model to behavior disorders study, like anxiety and depression (191, 192), what are supported by others (30, 167, 175, 178, 180, 184). A recent literature review that collected information on genetic basis about SHR and yours origin strains confirmed that are genetic variability of animals from different laboratories and indicated that genetic variants present in the outbred strains from which SHR are created generated differences in hypertension development (18). The information pointed out here indicates the need for prior examination regarding the genetic origin and characteristics of the animals provided by the various laboratories, since there are certainly several differences between their practices and between the animals raised and supplied.

The experimental dilemma:

Table 2 presents the data extracted from the studies included in the review. Among the studies, one hundred and seven chose to use male rats, only 8 used exclusively female rats and eleven studies used both, while thirty-five did not indicate the sex of the animals used. Coskinas and Price (1987) decide use female animals because they observed a great difference in body mass between males normotensive and hypertensive rats (80).

One of the dilemmas faced by the researchers is to pair the experimental groups by age, body mass or blood pressure. We observed that the majority of studies matched for age, since this is a determining factor in the hypertension development in SHR (11, 108, 126, 193). However, it is important to highlight that the WIS strain showed a higher body mass compared to the WKY and SHR in the most of studies, this is one of the factors to be observed and considered when selecting the experimental model. Another point is the blood pressure values. Clearly, the SHR presented higher blood pressure, as expected. However, in three studies the WIS exhibited higher blood pressure compared to WKY (44, 101, 109), while five studies the WKY presented higher values (47, 57, 72, 99, 133).

The studies included in the review had different objectives and analyzed a very wide range of variables. In the first decades, between 1970 and 2000, the focus was on autonomic variables, in which studies sought to understand the responsible factors for the emergence and development of EAH. However, it was discovered that the SHR and WKY animals could also be used as models for studies on behavioral disorders, such as depression, locomotor action, hyperactivity and attention deficit hyperactivity disorder (25). In the last decades - mainly after 2005- many studies that used the three experimental

strains promoted the analysis of behavioral disorders and the treatment for them were published, and this was a little explored area until then.

In 13.49% of the studies the WIS were indicated as the best control, while in 6.74% the WKY were considered as the appropriate strain. Hopp *et al.* indicated that WKY from *National Institutes of Health* presented propensity to blood pressure elevation (68). And because of this, they decide exclude of yours sample all WKY animals that present SBP above 130mmHg and they affirmed that be difficult applied WKY as SHR control without any reservation, indicating the parallel use of WIS and WKY (68). Tamura and col. following the same precautions about WKY use, indicating that just included animals of this strain that present SBP lowest that 130mmHg (70). Another study points that WKY presented properties of smooth muscle very close to SHR, indicating a relationship with hypertension state (120).

One study that evaluated the adrenal gland structure indicate that WIS differ from WKY about volume of zona fascicular cells, mitochondria, smooth, endoplasmic reticulum and lysosomes and they are not most reliable control for SHR (39). They justified this pointing that WKY are closer in genetic constitution of SHR (39). Harvey *et al.* (2013) found that WIS rats present reduced learn capacity compared to WKY and close to SHR and based on this, they indicated that WKY are more appropriated to SHR control for this type of analyzes (171).

From the analyzed studies was found that in 68.4% of the articles the normotensive animals showed similar results, and some of these indicating the use parallel controls to SHR, suggesting that WKY and WIS are adequate animals for this (25, 28, 42, 94, 148, 178, 180). Dun and col. indicated that such comparisons may produce new insights about hypertension effects and perhaps there is not be apparent if only the WKY were used as control (42). Somkuwar *et al.* point that studies that use just WKY are reference control have been disapproved because some variables can be under or overestimated if the parallel control are not used (167). In 1978, Hodgins and Frohlich (1978) indicated the use of the two strains, since there appear to be physical and hemodynamic differences between them, implying that neither one alone may be a completely appropriate control when investigating hypertension-related parameters (41). Lundin *et al.* made a similar statement, indicating that one control complements the other (21).

Langen and Dost (2011) point that WIS and WKY present similarities and differences depend of which variable is analyzed and that requires a deep discussion (30).

This review supports this theory and point that both can be used as SHR control. Considering this, the researches need to be caution and analyzed what animal select based on your objectives, leading in count factors as laboratory of origin of animals, body mass and mainly, blood pressure measurement.

5- References:

1. Borko H. Information Science: What Is It? American Documentation. 1968:3-5.
2. Ferreira LM, Hochman B, Barbosa MVJ. Modelos experimentais em pesquisa. Acta Cirúrgica Brasileira. 2005;20(2):28-34.
3. Fagundes DJ, Taha MO. Modelo animal de doença: critérios de escolha e espécies de animais de uso corrente. Acta Cirúrgica Brasileira. 2004;19(1):59-65.
4. Smirk FH, Hall WH. Inherited hypertension in rats. Nature. 1958 Sep 13;182(4637):727-8.
5. Okamoto K, Aoki K. Development of a strain of spontaneously hypertensive rats. Jpn Circ J. 1963 Mar;27:282-93.
6. Alexander N, Hinshaw LB, Drury DR. Development of a strain of spontaneously hypertensive rabbits. Proc Soc Exp Biol Med. 1954 Aug-Sep;86(4):855-8.
7. Phelan EL, Smirk FH. Cardiac hypertrophy in genetically hypertensive rats. The Journal of Pathology and Bacteriology. 1962;80:445-8.
8. Page IH. A Method for Producing Persistent Hypertension by Cellophane. Science. 1939 Mar 24;89(2308):273-4.
9. Phelan EL, Eryetishir I, Smirk FH. Observations on the responses of rats with spontaneous hypertension and control rats to pressor drugs and to hexamethonium. Circ Res. 1962 May;10:817-24.
10. Okamoto K, Tabei R, Fukushima M, Nosaka S, Yamori Y. Further observations of the development of a strain of spontaneously hypertensive rats. Jpn Circ J. 1966 Jun;30(6):703-16.
11. Doggrell SA, Brown L. Rat models of hypertension, cardiac hypertrophy and failure. Cardiovascular Research. 1998 Jul;39(1):89-105.
12. Kurtz TW, Montano M, Chan L, Kabra P. Molecular evidence of genetic heterogeneity in Wistar-Kyoto rats: implications for research with the spontaneously hypertensive rat. Hypertension. 1989 Feb;13(2):188-92.
13. Kurtz TW, Morris RC, Jr. Biological variability in Wistar-Kyoto rats. Implications for research with the spontaneously hypertensive rat. Hypertension. 1987 Jul;10(1):127-31.
14. Deschepper CF, Picard S, Thibault G, Touyz R, Rouleau JL. Characterization of myocardium, isolated cardiomyocytes, and blood pressure in WKHA and WKY rats. Am J Physiol Heart Circ Physiol. 2002 Jan;282(1):H149-55.
15. Collins HL, Loka AM, DiCarlo SE. Daily exercise-induced cardioprotection is associated with changes in calcium regulatory proteins in hypertensive rats. American Journal of Physiology-Heart and Circulatory Physiology. 2005;288:H532-H40.
16. Atanur SS, Diaz AG, Maratou K, Sarkis A, Rotival M, Game L, et al. Genome sequencing reveals loci under artificial selection that underlie disease phenotypes in the laboratory rat. Cell. 2013 Aug 1;154(3):691-703.
17. Bailey DW. Recombinant-inbred strains. An aid to finding identity, linkage, and function of histocompatibility and other genes. Transplantation. 1971 Mar;11(3):325-7.
18. Doris PA. Genetics of hypertension: an assessment of progress in the spontaneously hypertensive rat. Physiol Genomics. 2017 Nov 1;49(11):601-17.
19. Yosida TH, Amano K. Autosomal polymorphism in laboratory bred and wild Norway rats, *Rattus norvegicus*, found in Misima. Chromosoma. 1965 Jun 28;16(6):658-67.
20. Eichelman B, Dejong W, Williams RB. Aggressive behavior in hypertensive and normotensive rat strains. Physiol Behav. 1973 Feb;10(2):301-4.
21. Lundin S, Herlitz H, Hallback-Nordlander M, Ricksten SE, Gothberg G, Berglund G. Sodium balance during development of hypertension in the spontaneously hypertensive rat (SHR). Acta Physiol Scand. 1982 Jul;115(3):317-23.
22. Nishiyama K, Nishiyama A, Frohlich ED. Regional blood flow in normotensive and spontaneously hypertensive rats. Am J Physiol. 1976 Mar;230(3):691-8.

23. Herlitz H, Lundin S, Henning M, Aurell M, Karlberg BE, Berglund G. Hormonal pattern during development of hypertension in spontaneously hypertensive rats (SHR). *Clin Exp Hypertens A*. 1982;4(6):915-35.
24. Felten SY, Weyhenmeyer JA, Felten DL. Norepinephrine and serotonin in central autonomic nuclei in the spontaneously hypertensive rat and two normotensive control rats. *Brain Res Bull*. 1984 Sep;13(3):437-41.
25. Hard E, Carlsson SG, Jern S, Larsson K, Lindh AS, Svensson L. Behavioral reactivity in spontaneously hypertensive rats. *Physiol Behav*. 1985 Oct;35(4):487-92.
26. Soderpalm B. The SHR exhibits less "anxiety" but increased sensitivity to the anticonflict effect of clonidine compared to normotensive controls. *Pharmacol Toxicol*. 1989 Nov;65(5):381-6.
27. Sagvolden T, Pettersen MB, Larsen MC. Spontaneously hypertensive rats (SHR) as a putative animal model of childhood hyperkinesis: SHR behavior compared to four other rat strains. *Physiol Behav*. 1993 Dec;54(6):1047-55.
28. Gattone VH, 2nd. Body weight of the spontaneously hypertensive rat during the suckling and weaning periods. *Jpn Heart J*. 1986 Nov;27(6):881-4.
29. Bizot JC, Chenault N, Houze B, Herpin A, David S, Pothion S, et al. Methylphenidate reduces impulsive behaviour in juvenile Wistar rats, but not in adult Wistar, SHR and WKY rats. *Psychopharmacology (Berl)*. 2007 Aug;193(2):215-23.
30. Langen B, Dost R. Comparison of SHR, WKY and Wistar rats in different behavioural animal models: effect of dopamine D1 and alpha2 agonists. *Atten Defic Hyperact Disord*. 2011 Mar;3(1):1-12.
31. Sanada LS, Tavares MR, Neubern MC, Salgado HC, Fazan VP. Can Wistar rats be used as the normotensive controls for nerve morphometry investigations in spontaneously hypertensive rats (SHR)? *Acta Cir Bras*. 2011 Dec;26(6):514-20.
32. Gordon CJ, Phillips PM, Johnstone AF. Impact of genetic strain on body fat loss, food consumption, metabolism, ventilation, and motor activity in free running female rats. *Physiol Behav*. 2016 Jan 1;153:56-63.
33. Tricco AC, Lillie E, Zarin W, O'Brien KK, Colquhoun H, Levac D, et al. PRISMA Extension for Scoping Reviews (PRISMA-ScR): Checklist and Explanation. *Ann Intern Med*. 2018 Oct 2;169(7):467-73.
34. Peters MD, Godfrey CM, Khalil H, McInerney P, Parker D, Soares CB. Guidance for conducting systematic scoping reviews. *Int J Evid Based Healthc*. 2015 Sep;13(3):141-6.
35. Novikov AM, Novikov DA. *Research methodology: From philosophy of science to research design*. 2013.
36. Omran AR. The epidemiologic transition. A theory of the epidemiology of population change. *Milbank Mem Fund Q*. 1971 Oct;49(4):509-38.
37. Tobia AJ, Lee JY, Walsh GM. Regional blood flow and vascular resistance in the spontaneously hypertensive rat. *Cardiovasc Res*. 1974 Nov;8(6):758-62.
38. Frohlich ED, Pfeffer MA. Adrenergic mechanisms in human hypertension and in spontaneously hypertensive rats. *Clin Sci Mol Med Suppl*. 1975 Jun;2:225s-38s.
39. Nickerson PA. The adrenal cortex in spontaneously hypertensive rats. A quantitative ultrastructural study. *Am J Pathol*. 1976 Sep;84(3):545-60.
40. Mullins MM, Banks RO. Age-related changes in Na⁺ excretion in saline-loaded spontaneously hypertensive rats. *Am J Physiol*. 1976 Nov;231(5 Pt. 1):1364-70.
41. Hodgins DS, Frohlich ED. Cardiac adenylate cyclase, cyclic nucleotide phosphodiesterase and lactate dehydrogenase in normotensive and spontaneously hypertensive rats. *Biochem Pharmacol*. 1978;27(8):1179-85.
42. Dunn FG, Pfeffer MA, Frohlich ED. ECG alterations with progressive left ventricular hypertrophy in spontaneous hypertension. *Clin Exp Hypertens*. 1978;1(1):67-86.
43. Cox RH. Comparison of arterial wall mechanics in normotensive and spontaneously hypertensive rats. *Am J Physiol*. 1979 Aug;237(2):H159-67.

44. Johnson EM, Jr., Macia RA. Unique resistance to guanethidine-induced chemical sympathectomy of spontaneously hypertensive rats: a resistance overcome by treatment with antibody to nerve growth factor. *Circ Res.* 1979 Aug;45(2):243-9.
45. Collis MG, de May C, Vanhoutte PM. Enhanced release of noradrenaline in the kidney of the young spontaneously hypertensive rat. *Clin Sci (Lond).* 1979 Dec;57 Suppl 5:233s-4s.
46. Postnov YV, Orlov SN. Evidence of altered calcium accumulation and calcium binding by the membranes of adipocytes in spontaneously hypertensive rats. *Pflugers Arch.* 1980 May;385(1):85-9.
47. Altura BM, Carella A, Altura BT. Magnesium ions control prostaglandin reactivity of venous smooth muscle from spontaneously hypertensive rats. *Prostaglandins Med.* 1980 Apr;4(4):255-61.
48. Nordborg C, Johansson BB. Morphometric study on cerebral vessels in spontaneously hypertensive rats. *Stroke.* 1980 May-Jun;11(3):266-70.
49. Haack DW, Schaffer JJ, Simpson JG. Comparisons of cutaneous microvessels from spontaneously hypertensive, normotensive Wistar-Kyoto, and normal Wistar rats. *Proc Soc Exp Biol Med.* 1980 Sep;164(4):453-8.
50. Lukacsko P, Messina EJ, Kaley G. Reduced hypotensive action of arachidonic acid in the spontaneously hypertensive rat. *Hypertension.* 1980 Sep-Oct;2(5):657-63.
51. Webb RC, VANHOUTTE MDP, BOHR DF. Adrenergic Neurotransmission in Vascular Smooth Muscle from Spontaneously Hypertensive Rats. *Hypertension.* 1980;3(1).
52. O'Donnell A, Volicer L. Thermoregulation in spontaneously hypertensive rats: effects of antihypertensive treatments. *Clin Exp Hypertens.* 1981;3(3):555-67.
53. Kitamura Y, Ishise S, Pegram BL, Kawamura H, Frohlich ED. Hemodynamic responses to bilateral lesions of the nucleus tractus solitarius in spontaneously hypertensive and normotensive rats. *Hypertension.* 1981 May-Jun;3(3):362-6.
54. Mullins MM, Kleinman LI, Russell PT, Srivastava LS. Plasma aldosterone concentrations in neonatal spontaneously hypertensive rats. *Life Sci.* 1982 Dec 13;31(24):2751-5.
55. Picotti GB, Carruba MO, Ravazzani C, Bondiolotti GP, Da Prada M. Plasma catecholamine concentrations in normotensive rats of different strains and in spontaneously hypertensive rats under basal conditions and during cold exposure. *Life Sci.* 1982 Nov 8;31(19):2137-43.
56. Lukacsko P. Effect of arachidonic acid on the basal release of prostaglandins E2 and I2 by rat arteries during the development of hypertension. *Clin Exp Hypertens A.* 1983;5(9):1471-83.
57. Borkowski KR, Quinn P. Validation of indirect systolic blood pressure measurement in ether anaesthetised rats. *J Auton Pharmacol.* 1983 Sep;3(3):157-60.
58. Hausler A, Girard J, Baumann JB, Ruch W, Otten UH. Long-term effects of betamethasone on blood pressure and hypothalamo-pituitary-adrenocortical function in spontaneously hypertensive and normotensive rats. *Horm Res.* 1983;18(4):191-7.
59. Takahashi M, Inoue A, Takeda K, Okajima H, Sasakim S, Yoshimuram M, et al. Augmented Central Cholinergic Mechanisms in Spontaneously Hypertensive Rats. *Japanese Heart Journal.* 1983.
60. Preuss HG, Goldin H. Serum renotropic activity and renal growth in spontaneously hypertensive rats. *Kidney Int.* 1983 Apr;23(4):635-42.
61. Martin JR, Quock RM. Pharmacological characterization of apomorphine-induced hypothermia in the spontaneously hypertensive rat. *Life Sci.* 1984 Aug 27;35(9):929-36.
62. Krukoff TL, Calaresu FR. Cytochrome oxidase activity in the hypothalamus of SHR and normotensive rats before and after fasting. *Brain Res.* 1984 Nov 19;322(1):75-82.
63. Miasiro N, Paiva TB, Pereira CC, Shimuta SI. Reactivity to bradykinin and potassium of the isolated duodenum from rats with genetic and renal hypertension. *Br J Pharmacol.* 1985 Jul;85(3):639-46.
64. Loeb AL, Bean BL. Antihypertensive drugs inhibit hypertension-associated aortic DNA synthesis in the rat. *Hypertension.* 1986 Dec;8(12):1135-42.

65. Kino M, Tamura H, Hopp L, Tokushige A, Searle BM, Aviv A. The effect of melittin on Na⁺ and Rb⁺ transport in cultured skin fibroblasts of the spontaneously hypertensive rat. *Clin Exp Hypertens A*. 1985;7(9):1283-99.
66. Farman N, Bonalet JP. Aldosterone binding in isolated tubules. IV. Autoradiography along the nephron of the spontaneously hypertensive rat. *Am J Physiol*. 1985 Jul;249(1 Pt 2):F99-106.
67. Docherty JR, Warnock P. Reduced alpha 1-adrenoreceptor mediated responsiveness in vas deferens from spontaneously hypertensive rats. *J Auton Pharmacol*. 1986 Dec;6(4):319-22.
68. Hopp L, Khalil F, Tamura H, Kino M, Searle BM, Tokushige A, et al. Ouabain binding to cultured vascular smooth muscle cells of the spontaneously hypertensive rat. *Am J Physiol*. 1986 Jun;250(6 Pt 1):C948-54.
69. Leysac PP, Jensen PK, Holstein-Rathlou NH. A study of proximal tubular compliances in normotensive and spontaneously hypertensive rats, and the effect of anaesthesia on the compliance. *Acta Physiol Scand*. 1986 Mar;126(3):341-8.
70. Tamura H, Hopp L, Kino M, Tokushige A, Searle BM, Khalil F, et al. Na⁺-K⁺ regulation in cultured vascular smooth muscle cell of the spontaneously hypertensive rat. *Am J Physiol*. 1986 Jun;250(6 Pt 1):C939-47.
71. Tokushige A, Kino M, Tamura H, Hopp L, Searle BM, Aviv A. Bumetanide-sensitive sodium-22 transport in vascular smooth muscle cell of the spontaneously hypertensive rat. *Hypertension*. 1986 May;8(5):379-85.
72. Head GA, de Jong W. Differential blood pressure responses to intracisternal clonidine, alpha-methyl dopa, and 6-hydroxydopamine in conscious normotensive and spontaneously hypertensive rats. *J Cardiovasc Pharmacol*. 1986 Jul-Aug;8(4):735-42.
73. Toivanen A, Merilahti-Palo R, Gripenberg C, Lahesmaa-Rantala R, Soderstrom KO, Jaakkola UM. Yersinia-associated arthritis in the rat: experimental model for human reactive arthritis? *Acta Pathol Microbiol Immunol Scand C*. 1986 Dec;94(6):261-9.
74. Sladek JR, Jr., Davis BJ, Sladek CD. Localization of vasopressin-neurophysin and norepinephrine in the supraoptic nucleus of spontaneously hypertensive rats. *Brain Res*. 1986 Feb 19;365(2):293-304.
75. Feig PU, D'Occhio MA, Boylan JW. Lymphocyte membrane sodium-proton exchange in spontaneously hypertensive rats. *Hypertension*. 1987 Mar;9(3):282-8.
76. Sitsen JMA, Nijkamp FP, Jong W. Differential Sensitivity to Morphine in Spontaneously Hypertensive and Normotensive Wistar-Kyoto and Wistar Rats. *Clin And expert-theory and practice*. 1987;9(7):1159-71.
77. Hilgenfeldt U, Schott R. Differences in pattern of plasma angiotensinogen in native and nephrectomized rats. *Hypertension*. 1987 Apr;9(4):339-44.
78. Khalil F, Fine B, Kuriyama S, Hatori N, Nakamura A, Nakamura M, et al. Increased atrial natriuretic factor receptor density in cultured vascular smooth muscle cells of the spontaneously hypertensive rat. *Clin Exp Hypertens A*. 1987;9(4):741-52.
79. Lang DJ, Johns BL. Venule distension properties in Wistar, Wistar-Kyoto, and spontaneously hypertensive rats. *Am J Physiol*. 1987 Apr;252(4 Pt 2):H714-20.
80. Coskinas E, Price JM. Length-dependent sensitivity of vascular smooth muscle in normotensive and hypertensive animals. *Am J Physiol*. 1987 Aug;253(2 Pt 2):H402-11.
81. Kunes J, Pang SC, Cantin M, Genest J, Hamet P. Cardiac and renal hyperplasia in newborn spontaneously hypertensive rats. *Clin Sci (Lond)*. 1987 Mar;72(3):271-5.
82. Feres T, Borges AC, Silva EG, Paiva AC, Paiva TB. Impaired function of alpha-2 adrenoreceptors in smooth muscle of mesenteric arteries from spontaneously hypertensive rats. *Br J Pharmacol*. 1998 Nov;125(6):1144-9.
83. Lariviere R, Baribeau J, St-Louis J, Schiffrin EL. Vasopressin receptors and inositol trisphosphate production in blood vessels of spontaneously hypertensive rats. *Can J Physiol Pharmacol*. 1989 Mar;67(3):232-9.

84. Nakamura M, Nakamura A, Fine B, Aviv A. Blunted cGMP response to ANF in vascular smooth muscle cells of SHR. *Am J Physiol.* 1988 Nov;255(5 Pt 1):C573-80.
85. Belichard P, Pruneau D, Rochette L. Influence of spontaneous hypertension and cardiac hypertrophy on the severity of ischemic arrhythmias in the rat. *Basic Res Cardiol.* 1988 Sep-Oct;83(5):560-6.
86. Paré W. "Behavioral Despair" Test Predicts Stress Ulcer in WKY Rats. *Physiology & Behavior.* 1989;46:483-7.
87. Pare WP. Stress ulcer and open-field behavior of spontaneously hypertensive, normotensive, and Wistar rats. *Pavlov J Biol Sci.* 1989 Apr-Jun;24(2):54-7.
88. Pare WP. Stress ulcer susceptibility and depression in Wistar Kyoto (WKY) rats. *Physiol Behav.* 1989 Dec;46(6):993-8.
89. Garcia R, Gauquelin G, Thibault G, Cantin M, Schiffrin EL. Glomerular atrial natriuretic factor receptors in spontaneously hypertensive rats. *Hypertension.* 1989 Jun;13(6 Pt 1):567-74.
90. Rodionov IM, Iarygin VN, Markov Kh M, Pinelis VG, Lakgueva FK, Tarasova OS, et al. [Increased number of sympathetic neurons in the superior cervical ganglia of rats of SHR and Wistar-Kyoto strains as compared with Wistar rats]. *Biull Eksp Biol Med.* 1989 Nov;108(11):620-2.
91. Harris EL, Grigor MR, Millar JA. Differences in mitogenic responses to angiotensin II, calf serum and phorbol ester in vascular smooth muscle cells from two strains of genetically hypertensive rat. *Biochem Biophys Res Commun.* 1990 Aug 16;170(3):1249-55.
92. Kawasaki H, Saito A, Takasaki K. Changes in calcitonin gene-related peptide (CGRP)-containing vasodilator nerve activity in hypertension. *Brain Res.* 1990 Jun 4;518(1-2):303-7.
93. Sonntag M, Schalike W, Brattstrom A. Cardiovascular effects of vasopressin micro-injections into the nucleus tractus solitarii in normotensive and hypertensive rats. *J Hypertens.* 1990 May;8(5):417-21.
94. Stein BA, Katzeff I, Norton G, De Wet G, Rosendorff C. Differential size distribution of atrial dense granules in spontaneously hypertensive, Wistar-Kyoto and Wistar rats. *Acta Anat (Basel).* 1990;137(4):331-5.
95. Alexander D, Gardner JP, Tomonari H, Fine BP, Aviv A. Lower Na(+)-H+ antiport activity in vascular smooth muscle cells of Wistar-Kyoto rats than spontaneously hypertensive and Wistar rats. *J Hypertens.* 1990 Sep;8(9):867-71.
96. Morton JJ, Beattie EC, Griffin SA, MacPherson F, Lyall F, Russo D. Vascular hypertrophy, renin and blood pressure in the young spontaneously hypertensive rat. *Clin Sci (Lond).* 1990 Nov;79(5):523-30.
97. Dumont M, Sabourin L, Lemaire S. Alterations of heart dynorphin-A in the development of spontaneously hypertensive rats. *Neuropeptides.* 1990 Jan;15(1):43-8.
98. Schini VB, Kim ND, Vanhoutte PM. The basal and stimulated release of EDRF inhibits the contractions evoked by endothelin-1 and endothelin-3 in aortae of normotensive and spontaneously hypertensive rats. *J Cardiovasc Pharmacol.* 1991;17 Suppl 7:S267-71.
99. Widimsky J, Kuchel O, Tremblay J, Hamet P. Distinct plasma atrial natriuretic factor, renin and aldosterone responses to prolonged high-salt intake in hypertensive and normotensive rats. *J Hypertens.* 1991 Mar;9(3):241-7.
100. Pollock DM, Arendshorst WJ. Effect of acute renal denervation and ANF on renal function in adult spontaneously hypertensive rats. *Am J Physiol.* 1991 Oct;261(4 Pt 2):R835-41.
101. Boylan JW, Van Liew JB, Feig PU. Inverse changes in erythroid cell volume and number regulate the hematocrit in newborn genetically hypertensive rats. *Proc Natl Acad Sci U S A.* 1991 Nov 1;88(21):9848-52.
102. Schiffrin EL, Parent A, St Louis J, Tremblay J, Garcia R, Thibault G. Vascular atrial natriuretic factor receptors in spontaneously hypertensive rats. *Cardiovasc Res.* 1992 Sep;26(9):857-64.

103. Saltzman D, DeLano FA, Schmid-Schonbein GW. The microvasculature in skeletal muscle. VI. Adrenergic innervation of arterioles in normotensive and spontaneously hypertensive rats. *Microvasc Res.* 1992 Nov;44(3):263-73.
104. Tabrizchi R, Triggle CR. Actions of L- and D-arginine and NG-monomethyl-L-arginine on the blood pressure of pithed normotensive and spontaneously hypertensive rats. *Clin Exp Hypertens A.* 1992;14(3):527-46.
105. Feres T, Vianna LM, Paiva AC, Paiva TB. Effect of treatment with vitamin D3 on the responses of the duodenum of spontaneously hypertensive rats to bradykinin and to potassium. *Br J Pharmacol.* 1992 Apr;105(4):881-4.
106. Magee JC, Schofield GG. Neurotransmission through sympathetic ganglia of spontaneously hypertensive rats. *Hypertension.* 1992 Sep;20(3):367-73.
107. Mamuya W, Chobanian A, Brecher P. Age-related changes in fibronectin expression in spontaneously hypertensive, Wistar-Kyoto, and Wistar rat hearts. *Circ Res.* 1992 Dec;71(6):1341-50.
108. Brooksby P, Levi AJ, Jones JV. Investigation of the mechanisms underlying the increased contraction of hypertrophied ventricular myocytes isolated from the spontaneously hypertensive rat. *Cardiovasc Res.* 1993 Jul;27(7):1268-77.
109. McLellan AR, Milligan G, Houslay MD, Connell JM. G-proteins in experimental hypertension: a study of spontaneously hypertensive rat myocardial and renal cortical plasma membranes. *J Hypertens.* 1993 Apr;11(4):365-72.
110. Tremblay J, Huot C, Willenbrock RC, Bayard F, Gossard F, Fujio N, et al. Increased cyclic guanosine monophosphate production and overexpression of atrial natriuretic peptide A-receptor mRNA in spontaneously hypertensive rats. *J Clin Invest.* 1993 Nov;92(5):2499-508.
111. Turrin MQ, dos Santos LF, da Veiga LV. Generation of atrial natriuretic peptide (ANP) in perfused lungs of spontaneously hypertensive rats (SHR). Comparison to Wistar-Kyoto (WKY) and Wistar (W) rat strains. *Comp Biochem Physiol C Comp Pharmacol Toxicol.* 1993 Feb;104(2):233-8.
112. Van Liew JB, Zamlauski-Tucker MJ, Feld LG. Endogenous creatinine clearance in the rat: strain variation. *Life Sci.* 1993;53(12):1015-21.
113. Klee A, Vater S, Schmid-Schonbein GW, Seiffge D. Evidence from comparative investigations that impaired platelet activation is not specific for stroke-prone spontaneously hypertensive rats. *Stroke.* 1993 Oct;24(10):1528-33.
114. Huang A, Sun D, Koller A. Endothelial dysfunction augments myogenic arteriolar constriction in hypertension. *Hypertension.* 1993 Dec;22(6):913-21.
115. Magnusson AM, Meyerson BJ. GABA-A agonist muscimol inhibits stimulated vasopressin release in the posterior pituitary of Sprague-Dawley, Wistar, Wistar-Kyoto and spontaneously hypertensive rats. *Neuroendocrinology.* 1993 Nov;58(5):519-24.
116. Morano I, Adler K, Weismann K, Knorr A, Erdmann E, Bohm M. Correlation of myosin heavy chain expression in the rat with cAMP in different models of hypertension-induced cardiac hypertrophy. *J Mol Cell Cardiol.* 1993 Apr;25(4):387-94.
117. Perez GN, Petroff MV, Mattiazzi A. Rested-state contractions and rest potentiation in spontaneously hypertensive rats. *Hypertension.* 1993 Sep;22(3):306-14.
118. Touyz RM, Tolloczko B, Schiffrin EL. Mesenteric vascular smooth muscle cells from spontaneously hypertensive rats display increased calcium responses to angiotensin II but not to endothelin-1. *J Hypertens.* 1994 Jun;12(6):663-73.
119. Magee JC, Schofield GG. Alterations of synaptic transmission in sympathetic ganglia of spontaneously hypertensive rats. *Am J Physiol.* 1994 Nov;267(5 Pt 2):R1397-407.
120. Silva EG, Frediani-Neto E, Ferreira AT, Paiva AC, Paiva TB. Role of Ca(+)-dependent K-channels in the membrane potential and contractility of aorta from spontaneously hypertensive rats. *Br J Pharmacol.* 1994 Nov;113(3):1022-8.

121. David-Dufilho M, Pernollet MG, Morris M, Astarie-Dekequer C, Devynck MA. Erythrocyte Ca²⁺ handling in the spontaneously hypertensive rat, effect of vanadate ions. *Life Sci.* 1994;54(4):267-74.
122. Rowland NE, Li BH, Fregly MJ, Smith GC. Fos induced in brain of spontaneously hypertensive rats by angiotensin II and co-localization with AT-1 receptors. *Brain Res.* 1995 Mar 27;675(1-2):127-34.
123. Dumont M, Lemaire S. Inhibitory effects of dynorphin-A on norepinephrine uptake by cardiac synaptosomal-mitochondrial fractions. *J Cardiovasc Pharmacol.* 1995 Apr;25(4):518-23.
124. Grisk O, Exner J, Schmidt M, Wacker S, Werner M, Honig A. Cardiorespiratory responses to acute hypoxia and hyperoxia in adult and neonatal spontaneously hypertensive and normotensive rats. *Clin Exp Hypertens.* 1995 Oct;17(7):1025-47.
125. Bian K, Bukoski RD. Myofilament calcium sensitivity of normotensive and hypertensive resistance arteries. *Hypertension.* 1995 Jan;25(1):110-6.
126. Touyz RM, Tolloczko B, Schiffrin EL. Blunted attenuation of angiotensin II-mediated Ca²⁺ transients by insulin in cultured unpassaged vascular smooth muscle cells from spontaneously hypertensive rats. *Am J Hypertens.* 1995 Feb;8(2):104-12.
127. Feng JJ, Arendshorst WJ. Enhanced renal vasoconstriction induced by vasopressin in SHR is mediated by V1 receptors. *Am J Physiol.* 1996 Aug;271(2 Pt 2):F304-13.
128. Findlay AL. The effect of losartan on drinking and NaCl intake in the rat in response to hyperosmotic and hypovolaemic stimuli: effect of route of administration and strain of rat. *Regul Pept.* 1996 Oct 8;66(1-2):95-100.
129. Blume A, Lebrun CJ, Herdegen T, Bravo R, Linz W, Mollenhoff E, et al. Increased brain transcription factor expression by angiotensin in genetic hypertension. *Hypertension.* 1997 Feb;29(2):592-8.
130. Gattu M, Pauly JR, Boss KL, Summers JB, Buccafusco JJ. Cognitive impairment in spontaneously hypertensive rats: role of central nicotinic receptors. I. *Brain Res.* 1997 Oct 10;771(1):89-103.
131. Touyz RM, Schiffrin EL. Role of calcium influx and intracellular calcium stores in angiotensin II-mediated calcium hyper-responsiveness in smooth muscle from spontaneously hypertensive rats. *J Hypertens.* 1997 Dec;15(12 Pt 1):1431-9.
132. Preuss HG, Zein M, MacArthy P, Dipette D, Sabnis S, Knapka J. Sugar-induced blood pressure elevations over the lifespan of three substrains of Wistar rats. *J Am Coll Nutr.* 1998 Feb;17(1):36-47.
133. Tanigawa K, Inoue Y, Tamura K. Insulin secretion and biosynthesis by the perfused pancreas of spontaneously hypertensive rats. *Metabolism.* 1999 Jan;48(1):3-6.
134. Kitami Y, Fukuoka T, Hiwada K, Inagami T. A high level of CCAAT-enhancer binding protein-delta expression is a major determinant for markedly elevated differential gene expression of the platelet-derived growth factor-alpha receptor in vascular smooth muscle cells of genetically hypertensive rats. *Circ Res.* 1999 Jan 8-22;84(1):64-73.
135. Dalle Lucca SL, Dalle Lucca JJ, Borges AC, Ihara SS, Paiva TB. Abnormal proliferative response of the carotid artery of spontaneously hypertensive rats after angioplasty may be related to the depolarized state of its smooth muscle cells. *Braz J Med Biol Res.* 2000 Aug;33(8):919-27.
136. Gros R, Chorazyczewski J, Meek MD, Benovic JL, Ferguson SS, Feldman RD. G-Protein-coupled receptor kinase activity in hypertension : increased vascular and lymphocyte G-protein receptor kinase-2 protein expression. *Hypertension.* 2000 Jan;35(1 Pt 1):38-42.
137. Hancock JC, Lindsay GW. Enhanced ganglionic responses to substance P in spontaneously hypertensive rats. *Peptides.* 2000 Apr;21(4):535-41.
138. Kawasaki H, Nuki Y, Yamaga N, Kurosaki Y, Taguchi T. Decreased depressor response mediated by calcitonin gene-related peptide (CGRP)-containing vasodilator nerves to spinal cord stimulation and levels of CGRP mRNA of the dorsal root ganglia in spontaneously hypertensive rats. *Hypertens Res.* 2000 Nov;23(6):693-9.

139. Casellas D, Bouriquet N, Artuso A, Walcott B, Moore LC. New method for imaging innervation of the renal preglomerular vasculature. Alterations in hypertensive rats. *Microcirculation*. 2000 Dec;7(6 Pt 1):429-37.
140. Akemi Sato M, Vanderlei Menani J, Ubriaco Lopes O, Colombari E. Lesions of the commissural nucleus of the solitary tract reduce arterial pressure in spontaneously hypertensive rats. *Hypertension*. 2001 Sep;38(3 Pt 2):560-4.
141. Ibarra M, Lopez-Guerrero JJ, Villalobos-Molina R. The influence of chloroethylclonidine-induced contraction in isolated arteries of Wistar Kyoto rats: alpha1D- and alpha1A-adrenoceptors, protein kinase C, and calcium influx. *Arch Med Res*. 2001 Jul-Aug;32(4):258-62.
142. Fox GB, Pan JB, Esbenshade TA, Bennani YL, Black LA, Faghieh R, et al. Effects of histamine H(3) receptor ligands GT-2331 and ciproxifan in a repeated acquisition avoidance response in the spontaneously hypertensive rat pup. *Behav Brain Res*. 2002 Apr 1;131(1-2):151-61.
143. Borges AC, Feres T, Vianna LM, Paiva TB. Cholecalciferol treatment restores the relaxant responses of spontaneously hypertensive rat arteries to bradykinin. *Pathophysiology*. 2002 Aug;8(4):263-8.
144. Aiello EA, Villa-Abrille MC, Escudero EM, Portiansky EL, Perez NG, de Hurtado MC, et al. Myocardial hypertrophy of normotensive Wistar-Kyoto rats. *Am J Physiol Heart Circ Physiol*. 2004 Apr;286(4):H1229-35.
145. Wickens JR, Macfarlane J, Booker C, McNaughton N. Dissociation of hypertension and fixed interval responding in two separate strains of genetically hypertensive rat. *Behav Brain Res*. 2004 Jul 9;152(2):393-401.
146. Shcherbin YI, Tsyrlin VA. Comparison of the somatosympathetic reflex in normotensive and spontaneously hypertensive rats. *Neurosci Behav Physiol*. 2004 Jul;34(6):563-7.
147. Bueno V, Palos M, Ronchi FA, Andrade MC, Ginoza M, Casarini DE. N-Domain angiotensin I-converting enzyme expression in renal artery of Wistar, Wistar Kyoto, and spontaneously hypertensive rats. *Transplant Proc*. 2004 May;36(4):1001-3.
148. van den Bergh FS, Bloemarts E, Chan JS, Groenink L, Olivier B, Oosting RS. Spontaneously hypertensive rats do not predict symptoms of attention-deficit hyperactivity disorder. *Pharmacol Biochem Behav*. 2006 Mar;83(3):380-90.
149. Kubo T, Hagiwara Y. Enhanced central hypertonic saline-induced activation of angiotensin II-sensitive neurons in the anterior hypothalamic area of spontaneously hypertensive and Dahl S rats. *Brain Res Bull*. 2006 Jan 30;68(5):335-40.
150. Sakamoto K, Yonoki Y, Fujioka T, Matsumura M, Mitsuta Y, Sano M, et al. Disappearance of glibenclamide-induced hypoglycemia in Wistar-Kyoto rats. *Biol Pharm Bull*. 2006 Mar;29(3):574-6.
151. Orduna V, Hong E, Bouzas A. Interval bisection in spontaneously hypertensive rats. *Behav Processes*. 2007 Jan 10;74(1):107-11.
152. Wheal AJ, Bennett T, Randall MD, Gardiner SM. Cardiovascular effects of cannabinoids in conscious spontaneously hypertensive rats. *Br J Pharmacol*. 2007 Nov;152(5):717-24.
153. Ribeiro RT, Afonso RA, Macedo MP. Hepatic parasympathetic role in insulin resistance on an animal model of hypertension. *Metabolism*. 2007 Feb;56(2):227-33.
154. Orduna V, Garcia A, Menez M, Hong E, Bouzas A. Performance of spontaneously hypertensive rats in a peak-interval procedure with gaps. *Behav Brain Res*. 2008 Aug 5;191(1):72-6.
155. Orduna V, Valencia-Torres L, Bouzas A. DRL performance of spontaneously hypertensive rats: dissociation of timing and inhibition of responses. *Behav Brain Res*. 2009 Jul 19;201(1):158-65.
156. Sandow SL, Gzik DJ, Lee RM. Arterial internal elastic lamina holes: relationship to function? *J Anat*. 2009 Feb;214(2):258-66.
157. Oliveira TR, Lamy MT, De Paula UM, Guimaraes LL, Toledo MS, Takahashi HK, et al. Structural properties of lipid reconstructs and lipid composition of normotensive and

hypertensive rat vascular smooth muscle cell membranes. *Braz J Med Biol Res.* 2009 Sep;42(9):844-53.

158. Percy CJ, Brown L, Power DA, Johnson DW, Gobe GC. Obesity and hypertension have differing oxidant handling molecular pathways in age-related chronic kidney disease. *Mech Ageing Dev.* 2009 Mar;130(3):129-38.

159. Tran ED, DeLano FA, Schmid-Schonbein GW. Enhanced matrix metalloproteinase activity in the spontaneously hypertensive rat: VEGFR-2 cleavage, endothelial apoptosis, and capillary rarefaction. *J Vasc Res.* 2010;47(5):423-31.

160. Dommett EJ, Rostron CL. Abnormal air righting behaviour in the spontaneously hypertensive rat model of ADHD. *Exp Brain Res.* 2011 Nov;215(1):45-52.

161. Ibias J, Pellon R. Schedule-induced polydipsia in the spontaneously hypertensive rat and its relation to impulsive behaviour. *Behav Brain Res.* 2011 Sep 30;223(1):58-69.

162. Castello-Ruiz M, Torregrosa G, Burguete MC, Salom JB, Gil JV, Miranda FJ, et al. Soy-derived phytoestrogens as preventive and acute neuroprotectors in experimental ischemic stroke: influence of rat strain. *Phytomedicine.* 2011 Apr 15;18(6):513-5.

163. Herman E, Knapton A, Rosen E, Zhang J, Estis J, Agee SJ, et al. Baseline serum cardiac troponin I concentrations in Sprague-Dawley, spontaneous hypertensive, Wistar, Wistar-Kyoto, and Fisher rats as determined with an ultrasensitive immunoassay. *Toxicol Pathol.* 2011 Jun;39(4):653-63.

164. Harvey RC, Sen S, Deaciuc A, Dwoskin LP, Kantak KM. Methylphenidate treatment in adolescent rats with an attention deficit/hyperactivity disorder phenotype: cocaine addiction vulnerability and dopamine transporter function. *Neuropsychopharmacology.* 2011 Mar;36(4):837-47.

165. Hill JC, Herbst K, Sanabria F. Characterizing operant hyperactivity in the Spontaneously Hypertensive Rat. *Behav Brain Funct.* 2012 Jan 26;8:5.

166. Dommett EJ, Rostron CL. Appetitive and consummative responding for liquid sucrose in the spontaneously hypertensive rat model of attention deficit hyperactivity disorder. *Behav Brain Res.* 2013 Feb 1;238:232-42.

167. Somkuwar SS, Darna M, Kantak KM, Dwoskin LP. Adolescence methylphenidate treatment in a rodent model of attention deficit/hyperactivity disorder: dopamine transporter function and cellular distribution in adulthood. *Biochem Pharmacol.* 2013 Jul 15;86(2):309-16.

168. Somkuwar SS, Jordan CJ, Kantak KM, Dwoskin LP. Adolescent atomoxetine treatment in a rodent model of ADHD: effects on cocaine self-administration and dopamine transporters in frontostriatal regions. *Neuropsychopharmacology.* 2013 Dec;38(13):2588-97.

169. Umehara M, Ago Y, Kawanai T, Fujita K, Hiramatsu N, Takuma K, et al. Methylphenidate and venlafaxine attenuate locomotion in spontaneously hypertensive rats, an animal model of attention-deficit/hyperactivity disorder, through alpha2-adrenoceptor activation. *Behav Pharmacol.* 2013 Aug;24(4):328-31.

170. Wang G, Thomsen K, Frokiaer J. Renal responses to acute volume expansion in spontaneously hypertensive rats is related to the baseline sodium excretion. *Scand J Clin Lab Invest.* 2013 Oct;73(7):529-37.

171. Harvey RC, Jordan CJ, Tassin DH, Moody KR, Dwoskin LP, Kantak KM. Performance on a strategy set shifting task during adolescence in a genetic model of attention deficit/hyperactivity disorder: methylphenidate vs. atomoxetine treatments. *Behav Brain Res.* 2013 May 1;244:38-47.

172. Jordan CJ, Harvey RC, Baskin BB, Dwoskin LP, Kantak KM. Cocaine-seeking behavior in a genetic model of attention-deficit/hyperactivity disorder following adolescent methylphenidate or atomoxetine treatments. *Drug Alcohol Depend.* 2014 Jul 1;140:25-32.

173. Nam H, Clinton SM, Jackson NL, Kerman IA. Learned helplessness and social avoidance in the Wistar-Kyoto rat. *Front Behav Neurosci.* 2014;8:109.

174. Grunblatt E, Bartl J, Iuhos DI, Knezovic A, Trkulja V, Riederer P, et al. Characterization of cognitive deficits in spontaneously hypertensive rats, accompanied by brain insulin receptor dysfunction. *J Mol Psychiatry*. 2015;3(1):6.
175. Somkuwar SS, Kantak KM, Dwoskin LP. Effect of methylphenidate treatment during adolescence on norepinephrine transporter function in orbitofrontal cortex in a rat model of attention deficit hyperactivity disorder. *J Neurosci Methods*. 2015 Aug 30;252:55-63.
176. Kodavanti UP, Ledbetter AD, Thomas RF, Richards JE, Ward WO, Schladweiler MC, et al. Variability in ozone-induced pulmonary injury and inflammation in healthy and cardiovascular-compromised rat models. *Inhal Toxicol*. 2015;27 Suppl 1:39-53.
177. Ibias J, Pellon R, Sanabria F. A microstructural analysis of schedule-induced polydipsia reveals incentive-induced hyperactivity in an animal model of ADHD. *Behav Brain Res*. 2015 Feb 1;278:417-23.
178. Brace LR, Kraev I, Rostron CL, Stewart MG, Overton PG, Dommett EJ. Auditory responses in a rodent model of Attention Deficit Hyperactivity Disorder. *Brain Res*. 2015 Dec 10;1629:10-25.
179. Ibias J, Miguens M, Pellon R. Effects of dopamine agents on a schedule-induced polydipsia procedure in the spontaneously hypertensive rat and in Wistar control rats. *J Psychopharmacol*. 2016 Sep;30(9):856-66.
180. Jordan CJ, Lemay C, Dwoskin LP, Kantak KM. Adolescent d-amphetamine treatment in a rodent model of attention deficit/hyperactivity disorder: impact on cocaine abuse vulnerability in adulthood. *Psychopharmacology (Berl)*. 2016 Dec;233(23-24):3891-903.
181. Jordan CJ, Taylor DM, Dwoskin LP, Kantak KM. Adolescent D-amphetamine treatment in a rodent model of ADHD: Pro-cognitive effects in adolescence without an impact on cocaine cue reactivity in adulthood. *Behav Brain Res*. 2016 Jan 15;297:165-79.
182. Kawabe T, Iwasa M, Kawabe K, Sapru HN. Attenuation of angiotensin type 2 receptor function in the rostral ventrolateral medullary pressor area of the spontaneously hypertensive rat. *Clin Exp Hypertens*. 2016;38(2):209-17.
183. Somkuwar SS, Kantak KM, Bardo MT, Dwoskin LP. Adolescent methylphenidate treatment differentially alters adult impulsivity and hyperactivity in the Spontaneously Hypertensive Rat model of ADHD. *Pharmacol Biochem Behav*. 2016 Feb;141:66-77.
184. Ibias J, Daniels CW, Miguens M, Pellon R, Sanabria F. The Effect of Methylphenidate on the Microstructure of Schedule-Induced Polydipsia in an animal model of ADHD. *Behav Brain Res*. 2017 Aug 30;333:211-7.
185. Rostron CL, Gaeta V, Brace LR, Dommett EJ. Instrumental conditioning for food reinforcement in the spontaneously hypertensive rat model of attention deficit hyperactivity disorder. *BMC Res Notes*. 2017 Oct 30;10(1):525.
186. Dela Pena I, Dela Pena IJ, de la Pena JB, Kim HJ, Shin CY, Han DH, et al. Methylphenidate and Atomoxetine-Responsive Prefrontal Cortical Genetic Overlaps in "Impulsive" SHR/NCrl and Wistar Rats. *Behav Genet*. 2017 Sep;47(5):564-80.
187. Rybnikova EA, Vetrovoia OV, Zenkoa MY. Comparative Characterization of Rat Strains (Wistar, Wistar-Kyoto, Sprague Dawley, Long Evans, LT, SHR, BD-IX) by Their Behavior, Hormonal Level and Antioxidant Status. *Journal of Evolutionary Biochemistry and Physiology*. 2018;54(5):374-82.
188. Hilbert P, Lindpaintner K, Beckmann JS, Serikawa T, Soubrier F, Dubay C, et al. Chromosomal mapping of two genetic loci associated with blood-pressure regulation in hereditary hypertensive rats. *Nature*. 1991 Oct 10;353(6344):521-9.
189. Jacob HJ, Lindpaintner K, Lincoln SE, Kusumi K, Bunker RK, Mao YP, et al. Genetic mapping of a gene causing hypertension in the stroke-prone spontaneously hypertensive rat. *Cell*. 1991 Oct 4;67(1):213-24.
190. Kreutz R, Struk B, Rubattu S, Hubner N, Szpirer J, Szpirer C, et al. Role of the alpha-, beta-, and gamma-subunits of epithelial sodium channel in a model of polygenic hypertension. *Hypertension*. 1997 Jan;29(1 Pt 1):131-6.

191. Sagvolden T, Dasbanerjee T, Zhang-James Y, Middleton F, Faraone S. Behavioral and genetic evidence for a novel animal model of Attention-Deficit/Hyperactivity Disorder Predominantly Inattentive Subtype. *Behav Brain Funct.* 2008 Dec 1;4:56.
192. Sagvolden T, Johansen EB, Woien G, Walaas SI, Storm-Mathisen J, Bergersen LH, et al. The spontaneously hypertensive rat model of ADHD--the importance of selecting the appropriate reference strain. *Neuropharmacology.* 2009 Dec;57(7-8):619-26.
193. Bing OH, Brooks WW, Robinson KG, Slawsky MT, Hayes JA, Litwin SE, et al. The spontaneously hypertensive rat as a model of the transition from compensated left ventricular hypertrophy to failure. *J Mol Cell Cardiol.* 1995 Jan;27(1):383-96.

CAPÍTULO 2

Is the Wistar rat a more suitable normotensive control for SHR to test blood pressure and cardiac structure and function?

Leonardo Rezende^a, Leôncio Soares^a, Filipe Drummond^a, Zavagli Suarez^a, Luciano Leite^a, Joel Rodrigues^a, Ferreira Leal^a, Lukiya Favarato^b, Emily Reis^b, Evandro Favarato^b, Miguel Carneiro-Júnior^a, Antônio Natali^a, Cândido Coimbra^c, Thales Prímola-Gomes^{a*}.

^a*Exercise Biology Laboratory, Physical Education Department, Federal University of Viçosa, Viçosa, MG, Brazil;* ^b*Veterinary Department, Federal University of Viçosa, Viçosa, MG, Brazil;* ^c*Laboratory of Endocrinology and Metabolism, Physiology and Biophysics Department, Federal University of Belo Horizonte, Belo Horizonte, MG, Brazil.*

Abstract:

Background: There are divergences in the literature regarding the experimental model (Wistar-WIS or Wistar Kyoto-WKY) to be used as control of the Spontaneously Hypertensive Rat (SHR). The characterization of these models in terms of cardiovascular parameters provides researchers with important tools at the time of selection and application in scientific research. **Objective:** The aim of this study was to evaluate the use of WIS (Wistar) and WKY (Wistar Kyoto) as Spontaneously Hypertensive Rat (SHR) control by assessing the long-term behavior of blood pressure and cardiac structure and function in these strains. **Methods:** To this end, WIS, WKY and SHR underwent longitudinal experiments. Blood pressure and body mass were measured every two weeks from the 8th to the 72nd. Echocardiographic analysis was performed in all groups with 16, 48 and 72 weeks of life. **Results:** The WIS group showed higher body mass compared to WKY and SHR ($p < 0.05$), but the WKY and SHR presented higher body mass variation along the time ($p < 0.05$). SHR exhibited increased values of systolic, diastolic e mean blood pressure compared to WKY and WIS, while the WKY showed, generally, higher values than WIS ($p < 0.05$). Related to cardiac function, SHR showed reduced values and the WKY presented an early decrease compared to WIS with aging ($p < 0.05$). **Conclusion:** WIS is a more suitable normotensive control for SHR than WKY in experiments to test blood pressure and cardiac structure and function.

Keywords: Hypertension; Laboratory animals; SHR; Blood pressure; Heart.

1- Introduction:

Experimental animals are usually applied in the study of human health and disease, including the use of rodents as experimental models for investigation of biological phenomenon similar to those observed in humans⁽¹⁻³⁾. Among them, the SHR is widely used as a model for essential hypertension investigation⁽³⁻⁵⁾. For those working with these experimental animals it is obvious and mandatory to adopt a control group in their experiments.

In this way, two experimental strains are nowadays used as SHR's controls, namely, WKY⁽⁶⁻⁸⁾ and WIS^(4, 5, 9). It is a historical fact that WKY was the SHR background and most used strain as SHR control in scientific research^(8, 10, 11). However, the WIS strain has also been used^(4, 5, 9, 12). Besides that, some previous studies have pointed out limitations in the use of both strains⁽¹³⁻¹⁸⁾.

Regarding these limitations, Kurtz & Morris (1987) studied the biological variability of WKY and SHR in two laboratories in the USA during 20 weeks. Differences in growth rate and mean arterial pressure (MAP), i.e., in biological variability in the WKY were found⁽¹⁷⁾. In a second study, the same group tested the genetic variability of these strains through genomic analysis and found differences between WKY of different laboratories and even between animals from the same laboratory⁽¹⁶⁾. Evidence also points to the presence of increased sympathetic activity in WKY as shown by baseline resting catecholamine concentrations similar to the levels found in SHR^(14, 19). In another study, Aiello *et al.* performed a series of experiments in the myocardial of WIS, WKY and SHR and found higher left ventricle mass:body mass ratio in WKY compared to WIS, indicating a hypertrophic process⁽¹³⁾. The study also found an increase in diastolic papillary muscles stiffness and fibrosis on left ventricle in the WKY similar to SHR and higher than WIS⁽¹³⁾.

On the other hand, limitations also have been pointed against the use of WIS. First of all there is the fact that it is not the SHR' background⁽¹⁰⁾. Furthermore, WIS have higher body mass values compared to WKY and SHR⁽²⁰⁾. This difference brings to light an experimental paradigm when selecting the control group since choosing WIS as control the researcher will assume to have two groups with different body weights⁽²¹⁾. To understand the growth behavior between WIS, WKY and SHR, a previous study analyzed their physical development immediately after birth, during suckling and weanling⁽²²⁾. It was found that WIS showed higher body mass than WKY and SHR. Additionally, WKY presented body mass similar to SHR at birth and higher body mass between the 1st and the 6th week of life⁽²²⁾. Searching the literature, there is a lack of data that characterizes the two strains to helps scientists to select the appropriate control for their experiments. For example, to the best of our knowledge, no study has been conducted to specifically evaluate the use of WIS as an alternative control for WKY.

Therefore, the present study aimed to evaluate the use of WIS and WKY as SHR control by assessing the long-term behavior of blood pressure and cardiac structure and function in these strains. We hypothesized that WIS is more suitable normotensive control for SHR than WKY in experiments to test blood pressure and cardiac structure and function.

2- Methods:

Animals:

Male WIS, WKY and SHR rats were used for all experiments from their 8th to 72nd week of life. The animals were housed in collective cages and allocated in a controlled environment with light/dark cycle (12/12h), temperature at 22 ± 2 °C, and had free access to food and water (*ad libitum*). The animals were obtained from the central biotery of the Federal University of Viçosa-UFV.

Ethical approval:

The experiments were conducted in accordance to the Guide for the Care in Laboratory Animal Use principles and approved by the Ethics Committee on the Use of Animals of the Federal University of Viçosa (Protocol 09/2018). All procedures were attended by a veterinarian.

Body mass:

Body mass (g) was obtained every two weeks, from the 8th to the 72nd week of life, on an electronic scale (Rochelle, model 3252). In order to monitor the animals weight gain behavior, body mass variation (Δ) was calculated.

Blood pressure:

Systolic Blood Pressure (SBP in mmHg) and Diastolic Blood Pressure (DBP in mmHg) were measured using the noninvasive method of tail plethysmography (LE5001; Panlab, Barcelona- Spain), as previously described ⁽²³⁾. Briefly, animals were adapted to a tail cuff and a heating apparatus during five consecutive days. After, animals underwent blood pressure measurements each two weeks. Each measurement was performed three times and the median value was used. All measurements were performed by the same researcher in a quiet environment ⁽²⁴⁾. Mean Arterial Pressure (MAP in mmHg) was calculated by the following equation: $DBP + 1/3(SBP-DBP)$.

Echocardiogram:

An echocardiographic analysis was performed in all groups with 16, 48 and 72 weeks of life. The animals underwent to inhalation anesthesia (Isoflurane 1.5% and 100% O₂ at constant flow rate of 1L/min; Isoflurane, BioChimio, RJ- Brazil) and placed in lateral decubitus position. Two-dimensional tests were performed with rapid sampling rate (frame rate) of 120 fps and M-mode, using the ultrasound system (MyLabTM30 - Esaote, Genoa- Italy) and 11.0 MHz nominal frequency transducers (phased array). Two-dimensional transthoracic echocardiography and M-mode were obtained at a scanning speed of 200 mm, adjusted according to heart rate. The images were collected according to the recommendations of the American Society of Echocardiography and stored for further analysis ⁽²⁵⁾. The left ventricle diameter in diastole (LVDd in mm), left ventricle diameter in systole (LVDs in mm), interventricular septum in diastole (IVSd in mm), interventricular septum in systole (IVSs in mm) posterior wall thickness in diastole (PWd in mm), ejection fraction (EF in %) and shortening fraction (FS in %) were measured using a modified method recommended by the American Society of Echocardiography for three consecutive cardiac cycles. The examinations were performed by a trained researcher through single-blinded method. Left ventricle mass (LVM in g) was calculated as follows ⁽²⁶⁾: $LVM = 0.8 (1.04 (IVSd + LVDd + PWd)^3 - (LVDd)^3) 0.14$. The ratio of LVM to body mass (LVM:BM in mg:g) was calculated as an index of ventricular hypertrophy.

Statistic:

The Shapiro-Wilk test was applied to analyze data normality. Two-Way ANOVA of repeated measures followed by Tukey *post hoc* tests were used to analyze body mass, Δ body mass, blood pressure and echocardiographic results. A significance level of 5% was set. Data are presented as mean \pm SD.

3- Results:

Body mass and body mass variation. Fig.1A shows the results for body mass. A strain effect for all groups was found ($p < 0.05$). WIS presented higher body mass than WKY and SHR during the entire period ($p < 0.05$). Also, between the 8th and the 20th weeks, WKY presented higher body mass compared to SHR ($p < 0.05$). Fig.1B shows the results for body mass variation. A strain effect for all groups was found ($p < 0.05$). SHR showed higher variation than WIS from the 22nd to the 72nd week ($p < 0.05$) and higher variation than WKY at 30th, 34th - 50th and 54th - 58th weeks

($p < 0.05$). It was also observed that WKY presented higher variation than WIS at 12th - 16th, 24th - 30th, 34th - 44th and 60th - 64th weeks ($p < 0.05$).

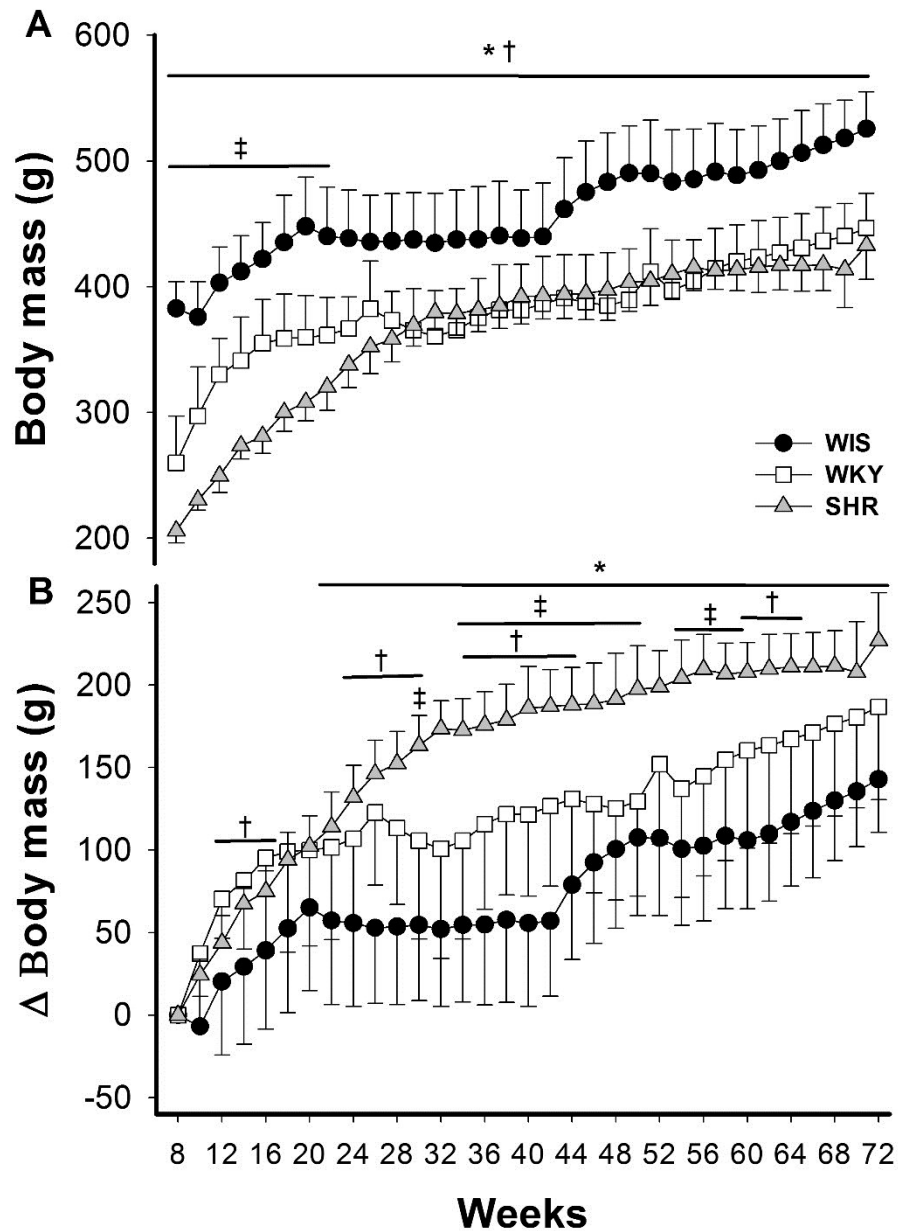

Figure 1. Long-term behavior of body mass (A) and Δ body mass (B) of WIS (n=8), WKY (n=8) and SHR (n=8) over 72^{wk}. Data are presented as mean \pm SD. Statistical significance ($p < 0.05$) are showed as follows: † = WIS vs. WKY; ‡ = WKY vs. SHR; * = WIS vs. SHR.

Blood pressure. There was a strain effect for all groups ($p < 0.05$). Fig.2A shows the results of SBP. SHR presented higher SBP than WIS and WKY during the entire experimental period ($p < 0.05$). Also, WKY presented higher SBP between the 10th and the 16th week and in the 20th, 26th, 30th and between 34th and 72nd weeks ($p < 0.05$). Fig.2B shows the results for DBP. SHR

presented higher DBP than WIS and WKY in the 8th week ($p < 0.05$). From the 16th week, SHR showed higher DBP than WIS ($p < 0.05$). In the 18th week and in-between the 22nd and 72nd weeks, SHR showed higher DBP than WKY ($p < 0.05$). WKY presented higher DBP than WIS from week 40 on, specifically in the 40th, 42nd, 46th – 50th, 56th – 62nd, 70th and 72nd weeks ($p < 0.05$). Fig.2C shows the MAP results. SHR presented higher MAP value than WIS during the entire experimental period ($p < 0.05$). Compared to WKY, and in the 8th, 14th, 18th, 22nd, 24th and 30th – 72nd weeks, SHR presented increased MAP ($p < 0.05$). WKY presented higher MAP than WIS in the 20th, 26th, 28th, 32nd, 40th – 48th, 54th – 58th, 70th and 72nd weeks ($p < 0.05$). Finally, in the SHR group it was observed a time-dependent increase in SBP, DBP and MAP from 28th week on.

Echocardiographic parameters. Fig.3 shown the representative echocardiographic images of animals with 16, 48 and 72 weeks of life. Tab.1 shows structural and functional echocardiographic results. Concerning cardiac structure, there was a strain effect for all groups for LVDd ($p < 0.05$). WKY presented lower LVDd than WIS and SHR in the 16th week ($p < 0.05$). In the 48th and 72nd weeks, WIS presented higher LVDd than WKY ($p < 0.05$). An aging effect was also observed. WIS and WKY showed increased in LVDd in the 48th and 72nd compared to the 16th weeks ($p < 0.05$). For LVDs, both strain and aging effects were observed. SHR showed higher LVDs than WIS and WKY ($p < 0.05$). WKY presented lower LVDs compared to WIS in the 16th week ($p < 0.05$). WIS and WKY presented increased LVDs in the 48th and 72nd compared to the 16th weeks ($p < 0.05$). A strain effect was observed for PWd. The WKY and SHR presented higher PWd compared to WIS in the 48th and 72nd weeks ($p < 0.05$). When analyzing the thickness of the interventricular septum no differences were found ($p > 0.05$). For LVM, both strain and aging effects were found ($p < 0.05$). SHR presented higher LVM compared to WIS and WKY in the 16th, 48th and 72nd weeks ($p < 0.05$). WKY and SHR showed increased LVM in the 48th and 72nd compared to the 16th weeks ($p < 0.05$). A strain effect was found for LVM:BM ($p < 0.05$). SHR presented higher LVM:BM compared to WIS and WKY in the 16th, 48th and 72nd weeks ($p < 0.05$).

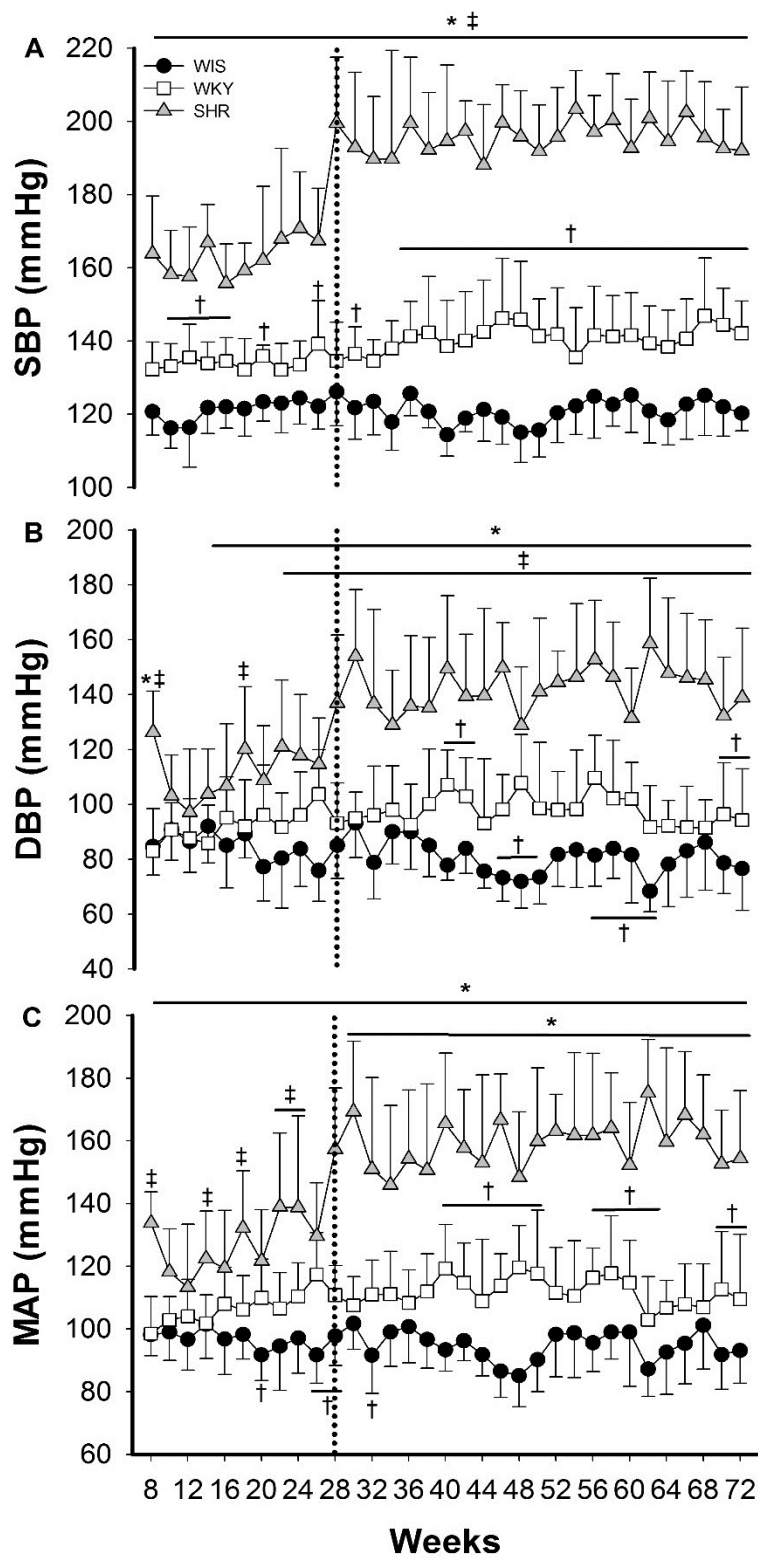

Figure 2. Long-term behavior of SBP (A), DBP (B) and MAP (C) of WIS (n=8), WKY (n=8) and SHR (n=8). The dotted line indicates the moment of significant increase in SHR. Data are presented as mean \pm SD. Statistical significance ($p < 0.05$) are showed as follows: † = WIS vs. WKY; ‡ = WKY vs. SHR; * = WIS vs. SHR.

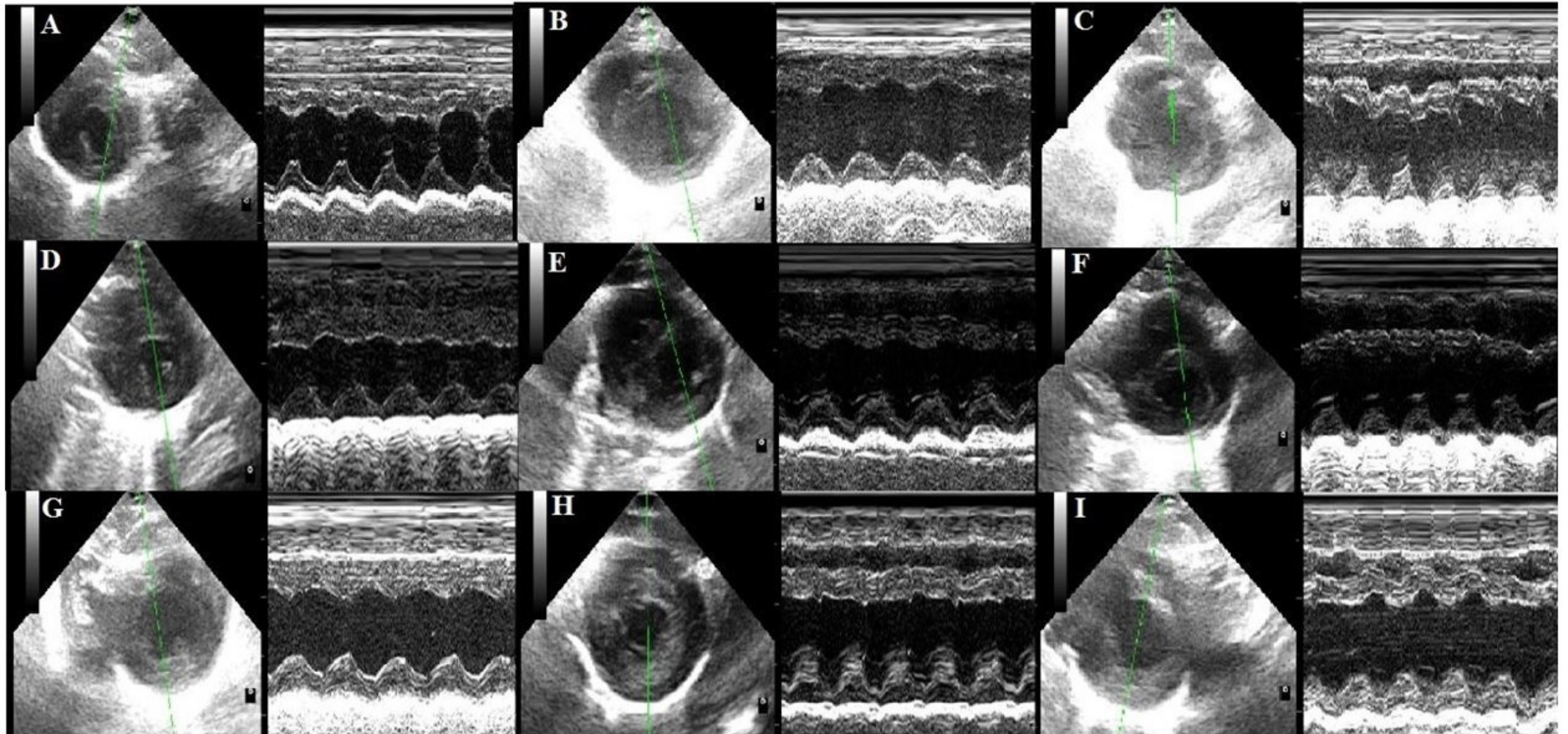

Figure 3. Representative echocardiographic images of animals with 16, 48 and 72 weeks of life. A= WIS16; B= WIS48; C= WIS72; D= WKY16; E= WKY48; F= WKY72; G= SHR16; H= SHR48; I= SHR72

Regarding cardiac function both strain and aging effects were found for EF ($p < 0.05$). SHR presented lower EF compared to WIS and WKY at 16th week ($p < 0.05$). WIS presented decreased EF in the 72nd compared to 16th week ($p < 0.05$), while WKY presented lower EF in the 48th and 72nd compared to the 16th weeks ($p < 0.05$). Regarding SF, both strain and aging effects were found ($p < 0.05$). SHR presented lower SF compared to WIS and WKY in the 16th week ($p < 0.05$). WKY presented decreased SF in the 48th and 72nd compared to 16th week ($p < 0.05$), while WIS presented a decrease of SF only in the 72nd week compared to the 16th and 48th weeks ($p < 0.05$).

Table 1. Long term behavior of morphological and functional echocardiographic parameters of WIS, WKY and SHR with 16, 48 and 72 weeks.

	<i>WIS16 (n=8)</i>		<i>WKY16 (n=8)</i>		<i>SHR16 (n=8)</i>		<i>WIS48 (n=6)</i>		<i>WKY48 (n=8)</i>		<i>SHR48 (n=8)</i>		<i>WIS72 (n=8)</i>		<i>WKY72 (n=8)</i>		<i>SHR72 (n=8)</i>	
<i>Morphological parameters</i>																		
<i>LVDD</i>	7.10	± 0.17	4.95	± 0.39 [†]	7.40	± 0.20 [‡]	8.60	± 0.23 [§]	7.56	± 0.31 ^{§†}	8.06	± 0.22	8.50	± 0.16 [#]	7.28	± 0.30 ^{#†}	8.06	± 0.33
<i>LVDs</i>	4.32	± 0.22	2.81	± 0.25 [†]	5.52	± 0.31 ^{*‡}	5.58	± 0.21 [§]	5.45	± 0.44 [§]	5.76	± 0.20	6.20	± 0.19 [#]	5.36	± 0.32 [#]	5.98	± 0.22
<i>IVSd</i>	1.79	± 0.07	1.93	± 0.17	1.90	± 0.08	1.82	± 0.12	1.57	± 0.18	2.08	± 0.08	1.83	± 0.10	1.69	± 0.13	1.93	± 0.11
<i>IVSs</i>	2.00	± 0.09	2.07	± 0.14	1.78	± 0.12	2.02	± 0.12	1.80	± 0.26	2.10	± 0.13	1.85	± 0.09	1.85	± 0.20	1.93	± 0.13
<i>PWd</i>	1.40	± 0.08	2.01	± 0.23	2.01	± 0.15	1.11	± 0.06	2.10	± 0.12 [†]	2.21	± 0.25 [*]	1.22	± 0.14	2.02	± 0.08 [†]	2.55	± 0.30 [*]
<i>LVM</i>	0.76	± 0.03	0.62	± 0.04	1.02	± 0.05 ^{*‡}	0.91	± 0.05	0.96	± 0.04 [§]	1.3	± 0.11 ^{§*&}	0.94	± 0.07	0.93	± 0.02 [#]	1.36	± 0.08 ^{#*‡}
<i>LVM/BM</i>	1.61	± 0.09	2.04	± 0.18	4.01	± 0.18 ^{*‡}	2.14	± 0.21	2.57	± 0.16	3.65	± 0.30 ^{*‡}	1.93	± 0.16	2.29	± 0.08	3.50	± 0.20 ^{*‡}
<i>Functional parameters</i>																		
<i>EF</i>	75.25	± 2.30	80.00	± 2.00	55.12	± 5.80 ^{*‡}	69.80	± 2.25	59.80	± 5.07 [§]	60.87	± 1.51	58.50	± 2.49 [#]	57.75	± 3.01 [#]	54.62	± 4.36
<i>FS</i>	39.50	± 1.90	43.37	± 2.18	25.75	± 3.23 ^{*‡}	35.50	± 1.58	28.50	± 3.10 [§]	28.75	± 0.99	27.30	± 1.49 ^{#¶}	26.87	± 1.82 [#]	25.50	± 2.52

LVDd– Left ventricle diameter in diastole (in mm); LVDs- Left ventricle diameter in systole (in mm); IVSd- Interventricular septum in diastole (in mm); IVSs- Interventricular septum in systole (in mm); PWd - Posterior wall thickness in diastole (in mm); LVM - Left ventricle mass (in g); LVM/BM - Left ventricle mass:body mass ratio (in mg:g); EF - Ejection fraction (in %); FS - Shortening fraction (in %). Data are presented as mean ± SD. Statistical significance (p<0.05) are showed as follows: † = WKY vs. WIS; ‡ = SHR vs. WKY; * = SHR vs. WIS; § = 48 vs. 16; # = 72 vs. 16; ¶ = 72 vs. 48.

4- Discussion:

The present study assessed the long-term behavior of blood pressure and cardiac structure and function in SHR and both WIS and WKY as controls. For this purpose, we assessed blood pressure and cardiac structure and function over 72 weeks. We confirmed our hypothesis that, regardless of body weight variations, when the cardiovascular issue is considered to select the control group, WIS is a more suitable normotensive control for SHR than WKY.

Our main findings were: 1) The blood pressure values in WKY were intermediate between SHR and WIS and close to hypertension borderline; and WIS showed pressure values more consistent with those expected for normotensive rats; and 2) WKY presented earlier reductions in cardiac function compared to WIS.

The correct choice of the control group is essential and has great importance, as it allows to analyze one variable at a time, making it possible to isolate the variable of interest^(27, 28). For such purpose, the scientific research must be systematically planned and executed, using appropriate methods and tools⁽²⁹⁾. Usually, the use of SHR as a model of essential hypertension requires a normotensive group as control^(4, 5, 30). However, researchers face an experimental paradigm, since they must choose controls matching by body mass or by age^(4, 21, 22, 31).

We found important differences in the body mass and body mass variation between the tested strains over 72 weeks. During entire life period, WIS present higher body mass than WKY and SHR. However, body mass variation was higher in WKY and SHR strains, which indicates accentuated growth in these strains. A previous work evaluated the food intake of five experimental strains, including WIS, WKY and SHR, and found increased food consumption in WKY and SHR, which can explain the higher body mass variation observed here⁽³¹⁾. However, it is important to highlight that the development of hypertension in SHR is age-dependent rather than body mass-dependent⁽²¹⁾.

According to Okamoto and Aoki (1963), the reference value to classify rats as hypertensive is SBP above 150 mmHg⁽¹⁰⁾. The experimental animals in the present study were classified as follows: WIS – normotensive (116-126 mmHg); WKY – normotensive (132-146 mmHg); and SHR - hypertensive (155-203 mmHg). This profile also reflected in altered MAP results. Despite the fact that WIS and WKY were classified as normotensive, it is important to note that WKY strain present higher SBP values than WIS and, more important, close to hypertension borderline. It is known that the chronic increase in blood pressure leads to consequences such as left ventricular concentric hypertrophy, arterial stiffness, stroke, myocardial infarction and heart failure⁽³²⁻³⁵⁾. Moreover, previous studies have shown divergent blood pressure variability among the WKY from different laboratories^(16, 17). Such differences have been

confirmed by several studies that classified WKY as both normotensive^(8, 13) and hypertensive^(6, 7, 11, 20, 36). It is noteworthy that no previous work was found assessing the biological variability of WIS. Thus, the long-term behavior of blood pressure observed in WKY group allows its use, though draws attention and requires caution in the use of these animals as SHR control.

It is also important to mention the abrupt increase in SBP, DBP and MAP in SHR on the 28th week. Such results may be explained by understanding the disease progression in SHR^(3, 37). Previous results show blood vessel hypertrophy on the 4th week of age as the first event related to the disease, despite the SBP values be still like normotensive⁽³⁸⁾. Additionally, the prehypertension stage can last up to 4th months of age⁽³⁾. After this moment, compensated hypertension is installed, in which the SHR reaches the SBP of 150 mmHg with an increase in the thickness of the cardiac walls concomitantly with the reductions in the left ventricular internal diameter. This structural rearrangement occurs to cope with the stress imposed by pressure overload on the cardiac walls and promote maintenance of systolic function and may last until the sixth month of age^(39, 40). Our data shows that around the 6th to the 7th month established and balanced hypertension is observed, characterizing the stage of decompensated hypertension^(37, 40). With the disease progression, between 18th and 24th months of age SHR reaches the heart failure stage⁽⁴⁰⁾. In fact, 20 week-old SHR presents higher SBP compared to that of 12 week-old animals⁽⁴¹⁾ and equivalent results have already been demonstrated by others^(38, 41).

Regarding the cardiac structure assessed by echocardiography, we observed that WKY with 16 weeks presented lower LVDD and LVDs compared to WIS and SHR. Moreover, LVDD was also lower in WKY than in WIS animals 48- and 72-week old. Both WIS and WKY presented increased LVDD and LVDs with aging. In addition, WKY and SHR showed higher PWD compared to WIS in weeks 48 and 72. Left ventricular remodeling is a process by which the cardiac chamber undergoes changes in its shape, size and function, and may occur as a result of either physiological (i.e. physical training)⁽⁸⁾ or pathophysiological (i.e. hypertension stimuli)⁽⁴²⁾. Pathophysiological hypertrophy is normally caused by high pressure overload in the cardiac chambers, leading to reductions in the left ventricular diameter, accompanied by increases in the ventricular walls' width⁽⁴³⁾.

Morphological changes directly affect cardiovascular function. The long-term pathological hypertrophy cause cardiac adverse remodeling of the extracellular matrix, such as increases in collagen content, which promote tissue stiffening, affecting thus the diastolic function leading to systolic dysfunction⁽⁴⁴⁾. The left ventricle is responsible for blood ejection and its morphology is crucial for pump appropriated functioning^(39, 45). We demonstrated that SHR group had higher values for LVM than WIS and WKY. With aging both WKY and SHR exhibited significant increases in LVM when compared to week 16th. To confirm the pathological

hypertrophic process the LVM/BM ratio was calculated ⁽⁴⁴⁾ and hypertrophy was not found in the WKY strain. Thus, probably the overload imposed by the increased SBP was not sufficient to promote pathological hypertrophy in WKY. However, a previous work found that the hemodynamic cardiac load is more evident in isolated cardiomyocytes than in whole ventricle ⁽⁷⁾. In addition to left ventricle analysis, the PwD of WKY and SHR was larger compared to WIS on weeks 48 and 72.

Concerning cardiac function, different from other study that showed late decreases in the cardiac function of SHR over lifetime ⁽³⁰⁾, in this study we found decreases in both EF and FS in SHR from the 16th week on. The WKY, however, presented normal values for EF and FS in the 16th week followed by reductions in the 48th and 72th weeks. This finding is in agreement with previous studies showing that WKY had diastolic dysfunction as a consequence of increased pressure overload ⁽¹³⁾. Finally, cardiac dysfunction was observed in WIS only in the 72th week.

5- Conclusions:

In conclusion, Wistar rat is a more suitable normotensive control for SHR than Wistar Kyoto in experiments to test issues related to blood pressure and cardiac structure and function in different ages inasmuch as Wistar Kyoto exhibits early reductions in cardiac function and values for blood pressure in the upper limit of normal pressure.

Acknowledgements:

This study was supported in part by CNPq (Conselho Nacional de Desenvolvimento Científico e Tecnológico), CAPES (Coordenação de Aperfeiçoamento de Pessoal de Nível Superior) and FAPEMIG (Fundação de Amparo à Pesquisa do Estado de Minas Gerais). AJ Natali is a CNPq fellow.

6- References:

1. Casals JB, Pieri NC, Feitosa ML, Ercolin AC, Roballo KC, Barreto RS, et al. The use of animal models for stroke research: a review. *Comp Med*. 2011 Aug;61(4):305-13.
2. Chatzigeorgiou A, Halapas A, Kalafatakis K, Kamper E. The use of animal models in the study of diabetes mellitus. *In Vivo*. 2009 Mar-Apr;23(2):245-58.
3. Doggrell SA, Brown L. Rat models of hypertension, cardiac hypertrophy and failure. *Cardiovascular Research*. 1998 Jul;39(1):89-105.
4. Campos HO, Leite LHR, Drummond LR, Cunha DNQ, Coimbra CC, Natali AJ, et al. Temperature Control of Hypertensive Rats during Moderate Exercise in Warm Environment. *J Sport Sci Med*. 2014 Sep;13(3):695-701.
5. Drummond LR, Kunstetter AC, Vaz FF, Campos HO, Andrade AG, Coimbra CC, et al. Brain Temperature in Spontaneously Hypertensive Rats during Physical Exercise in Temperate and Warm Environments. *Plos One*. 2016;11(5):e0155919.
6. Christensen KL. Reducing pulse pressure in hypertension may normalize small artery structure. *Hypertension*. 1991 Dec;18(6):722-7.
7. Deschepper CF, Picard S, Thibault G, Touyz R, Rouleau JL. Characterization of myocardium, isolated cardiomyocytes, and blood pressure in WKHA and WKY rats. *Am J Physiol Heart Circ Physiol*. 2002 Jan;282(1):H149-55.
8. Graham DA, Rush JW. Exercise training improves aortic endothelium-dependent vasorelaxation and determinants of nitric oxide bioavailability in spontaneously hypertensive rats. *J Appl Physiol (1985)*. 2004 Jun;96(6):2088-96.
9. Locatelli J, Paiva NCN, Carvalho SHR, Lavorato VN, Gomes L, Castro QJT, et al. Swim training attenuates the adverse remodeling of LV structural and mechanical properties in the early compensated phase of hypertension. *Life Sci*. 2017 Oct 15;187:42-9.
10. Okamoto K, Aoki K. Development of a strain of spontaneously hypertensive rats. *Jpn Circ J*. 1963 Mar;27:282-93.
11. Prieto I, Segarra AB, Gasparo M, Martínez-Cañameroa M, Ramírez-Sánchez M. Divergent profile between hypothalamic and plasmatic aminopeptidase activities in WKY and SHR. Influence of beta-adrenergic blockade. *Life Sciences*. 2018;192:9-17.
12. Gomes L, Drummond LR, Campos HO, Rezende LMT, Carneiro-Junior MA, Oliveira A, et al. Thermoregulation in Hypertensive Rats during Exercise: Effects of Physical Training. *Arq Bras Cardiol*. 2019 Mar 14.
13. Aiello EA, Villa-Abrille MC, Escudero EM, Portiansky EL, Perez NG, de Hurtado MC, et al. Myocardial hypertrophy of normotensive Wistar-Kyoto rats. *Am J Physiol Heart Circ Physiol*. 2004 Apr;286(4):H1229-35.
14. Chiueh CC, McCarty R. Sympatho-adrenal hyperreactivity to footshock stress but not to cold exposure in spontaneously hypertensive rats. *Physiol Behav*. 1981 Jan;26(1):85-9.

15. Collins HL, Loka AM, DiCarlo SE. Daily exercise-induced cardioprotection is associated with changes in calcium regulatory proteins in hypertensive rats. *American Journal of Physiology-Heart and Circulatory Physiology*. 2005;288:H532–H40.
16. Kurtz TW, Montano M, Chan L, Kabra P. Molecular evidence of genetic heterogeneity in Wistar-Kyoto rats: implications for research with the spontaneously hypertensive rat. *Hypertension*. 1989 Feb;13(2):188-92.
17. Kurtz TW, Morris RC, Jr. Biological variability in Wistar-Kyoto rats. Implications for research with the spontaneously hypertensive rat. *Hypertension*. 1987 Jul;10(1):127-31.
18. Langen B, Dost R. Comparison of SHR, WKY and Wistar rats in different behavioural animal models: effect of dopamine D1 and alpha2 agonists. *Atten Defic Hyperact Disord*. 2011 Mar;3(1):1-12.
19. Hendley ED, Cierpial MA, Mccarty R. Sympathetic-Adrenal Medullary Response to Stress in Hyperactive and Hypertensive Rats. *Physiology & Behavior*. 1988;44(1):47-51.
20. Sanada LS, Tavares MR, Neubern MC, Salgado HC, Fazan VP. Can Wistar rats be used as the normotensive controls for nerve morphometry investigations in spontaneously hypertensive rats (SHR)? *Acta Cir Bras*. 2011 Dec;26(6):514-20.
21. Hom S, Fleegal MA, Egleton RD, Campos CR, Hawkins BT, Davis TP. Comparative changes in the blood-brain barrier and cerebral infarction of SHR and WKY rats. *Am J Physiol Regul Integr Comp Physiol*. 2007 May;292(5):R1881-92.
22. Gattone VH, 2nd. Body weight of the spontaneously hypertensive rat during the suckling and weanling periods. *Jpn Heart J*. 1986 Nov;27(6):881-4.
23. Byrom FB, Wilson C. A plethysmographic method for measuring systolic blood pressure in the intact rat. *J Physiol*. 1938 Aug 15;93(3):301-4.
24. Fink GD. Does Tail-Cuff Plethysmography Provide a Reliable Estimate of Central Blood Pressure in Mice? *Journal of the American Heart Association*. 2017;6(6):1-3.
25. Sahn DJ, DeMaria A, Kisslo J, Weyman A. Recommendations regarding quantitation in M-mode echocardiography: results of a survey of echocardiographic measurements. *Circulation*. 1978 Dec;58(6):1072-83.
26. Brown L, Fenning A, Chan V, Loch D, Wilson K, Anderson B, et al. Echocardiographic assessment of cardiac structure and function in rats. *Heart Lung Circ*. 2002;11(3):167-73.
27. Kinser PA, Robins JL. Control group design: enhancing rigor in research of mind-body therapies for depression. *Evid Based Complement Alternat Med*. 2013;2013:140467.
28. Pithon MM. Importance of the control group in scientific research. *Dental Press J Orthod*. 2013 Nov-Dec;18(6):13-4.
29. Gu J, Li XB, Tian LH. [Scientific research accomplishment of medical staff]. *Zhonghua Yi Xue Za Zhi*. 2013 Mar 12;93(10):735-7.
30. Slama M, Ahn J, Varagic J, Susic D, Frohlich ED. Long-term left ventricular echocardiographic follow-up of SHR and WKY rats: effects of hypertension and age. *Am J Physiol Heart Circ Physiol*. 2004 Jan;286(1):H181-5.

31. Gordon CJ, Phillips PM, Johnstone AF. Impact of genetic strain on body fat loss, food consumption, metabolism, ventilation, and motor activity in free running female rats. *Physiol Behav.* 2016 Jan 1;153:56-63.
32. Chae CU, Pfeiffer MA, Glynn RJ, Mitchell GF, Taylor JO, Hennekens CH. Increased pulse pressure and risk of heart failure in the elderly. *JAMA.* 1999 Feb 17;281(7):634-9.
33. Levy D, Larson MG, Vasan RS, Kannel WB, Ho KK. The progression from hypertension to congestive heart failure. *JAMA.* 1996 May 22-29;275(20):1557-62.
34. McCrossan ZA, Billeter R, White E. Transmural changes in size, contractile and electrical properties of SHR left ventricular myocytes during compensated hypertrophy. *Cardiovasc Res.* 2004 Aug 1;63(2):283-92.
35. Pawlusch DG, Moore RL, Musch TI, Davidson WR, Jr. Echocardiographic evaluation of size, function, and mass of normal and hypertrophied rat ventricles. *J Appl Physiol* (1985). 1993 May;74(5):2598-605.
36. Bomfim GHS, Mendez-Lopez I, Fernandez-Morales JC, Padin JF, Jurkiewicz A, Jurkiewicz NH, et al. Electrophysiological properties and augmented catecholamine release from chromaffin cells of WKY and SHR rats contributing to the hypertension development elicited by chronic EtOH consumption. *Eur J Pharmacol.* 2017 May 15;803:65-77.
37. Boluyt MO, Bing OH, Lakatta EG. The ageing spontaneously hypertensive rat as a model of the transition from stable compensated hypertrophy to heart failure. *Eur Heart J.* 1995 Dec;16 Suppl N:19-30.
38. Adams MA, Bobik A, Korner PI. Differential development of vascular and cardiac hypertrophy in genetic hypertension. Relation to sympathetic function. *Hypertension.* 1989 Aug;14(2):191-202.
39. Grossman W. Cardiac hypertrophy: useful adaptation or pathologic process? *Am J Med.* 1980 Oct;69(4):576-84.
40. Bing OH, Brooks WW, Robinson KG, Slawsky MT, Hayes JA, Litwin SE, et al. The spontaneously hypertensive rat as a model of the transition from compensated left ventricular hypertrophy to failure. *J Mol Cell Cardiol.* 1995 Jan;27(1):383-96.
41. Bacharova L, Kyselovic J, Klimas J. The initial stage of left ventricular hypertrophy in spontaneously hypertensive rats is manifested by a decrease in the QRS amplitude/left ventricular mass ratio. *Clin Exp Hypertens.* 2004 Aug;26(6):557-67.
42. Ganau A, Devereux RB, Roman MJ, de Simone G, Pickering TG, Saba PS, et al. Patterns of left ventricular hypertrophy and geometric remodeling in essential hypertension. *J Am Coll Cardiol.* 1992 Jun;19(7):1550-8.
43. Grant C, Greene DG, Bunnell IL. Left ventricular enlargement and hypertrophy. A clinical and angiographic study. *Am J Med.* 1965 Dec;39(6):895-904.
44. Brower GL, Gardner JD, Forman MF, Murray DB, Voloshenyuk T, Levick SP, et al. The relationship between myocardial extracellular matrix remodeling and ventricular function. *European Journal of Cardio-Thoracic Surgery.* 2006;30(4):604-10.

45. Linzbach AJ. Heart failure from the point of view of quantitative anatomy. *Am J Cardiol.* 1960 Mar;5:370-82.

CAPÍTULO 3

Core temperature circadian rhythm across aging in Spontaneously Hypertensive Rats

Authors:

Leonardo M.T de Rezende^a, Leandro C. Brito^b, Anselmo G. Moura^a, Alexandre J.L.D. Costa^a, Tiago F. Leal^a, Evandro S. Favarato^c, Lukiya S.C. Favarato^c, Antônio J. Natali^a, Cândido C. Coimbra^d, Thales N. Prímola-Gomes^a.

a- Laboratório de Biologia do Exercício, Departamento de Educação Física, Universidade Federal de Viçosa, Viçosa, MG, Brasil.

b- Laboratório de Hemodinâmica da Atividade Locomotora, Escola de Educação Física e Esporte, Universidade de São Paulo, São Paulo, SP, Brasil. Escola de Artes, Ciências e Humanidades, Universidade de São Paulo, São Paulo, SP, Brasil.

c- Departamento de Medicina Veterinária, Universidade Federal de Viçosa, Viçosa, MG, Brasil.

d- Laboratório de Endocrinologia e Metabolismo, Departamento de Fisiologia e Biofísica, Universidade Federal de Minas Gerais, Belo Horizonte, MG, Brasil.

Abstract

The purpose of this study was to evaluate the circadian rhythm of core temperature (T_{core}) across aging in Spontaneously Hypertensive Rats (SHR) with comparison to the two rat strains often used as their normotensive control animals, namely, Wistar (WIS) and Wistar Kyoto (WKY). **Methods:** WIS, WKY and SHR rats were subdivided into three different groups according their age: WIS16, WIS48, WIS72, WKY16, WKY48, WKY72, SHR16, SHR48 and SHR72 weeks-old. Body mass and blood pressure were periodically measured along the experiments. All animal group had their circadian rhythm of T_{core} evaluated over three consecutive days (72 hours) by telemetry using an implanted temperature sensor. The T_{core} circadian rhythm was averaged in 1-h blocks and analyzed using the cosinor method. **Results:** Sixteen-week-old SHR (SHR16) presented higher T_{core} than WIS16 (from 06am to 06pm) and WKY16 (from 07am to 06pm). Both normotensive groups exhibited increases in T_{core} during circadian rhythm with aging. The cosinor analysis showed no differences between strains and ages for the acrophase. An age effect on the SHR strain (SHR16 < SHR72) was observed regarding the amplitude.

SHR16 had higher values regarding MESOR compared to WIS16 and WKY16. In addition, WIS72 and WKY72 showed higher values than WIS16 and WKY16, respectively. Finally, no differences were observed in the strength rhythm analysis.

Conclusions: SHR presented impaired thermoregulatory control at only 16 weeks of age when showing a higher body temperature during the activity phase, while other circadian rhythm parameters showed no differences across aging. Therefore, in taking our results as a whole we can conclude that WIS and WKY are appropriate Wistar strains to be used as normotensive controls for SHR.

Keywords: Circadian rhythm; body core temperature; hypertension; experimental strains.

1. Introduction

Several threats to human health have arisen in recent decades due to global warming and constant heat waves (Nybo et al., 2017). Thus, the study of thermoregulation has become extremely important, especially among hypertensive and aging populations who are known to be more susceptible to heat-related illnesses during heat waves (Argaud et al., 2007; Ellis, 1972). Accordingly, the development of experimental models to study these issues is essential. Therefore, despite the fact that Spontaneously Hypertensive Rat (SHR) is a widely used essential experimental model for human hypertension (Okamoto and Aoki, 1963), little is known about its thermoregulation including the T_{core} circadian rhythm in aging SHR.

The first studies aimed to evaluate thermoregulation in SHR usually found higher T_{core} values ($\sim 1^{\circ}\text{C}$) than that of normotensive Wistar Kyoto (WKY) (Wilson et al., 1977; O'Donnell and Volicer, 1981; Collins et al., 1987), which they attributed to: i) increased metabolic heat production uncompensated by increased respiratory evaporative heat loss or effective tissue thermal conductance (Collins et al., 1987); ii) impaired thermoregulatory cutaneous tail vasodilation (O'Leary and Wang, 1994); and iii) hypothalamic dysfunction (Wilson et al., 1977). It was later shown that SHR did not present baseline elevations in T_{core} when not stressed. In fact, it was shown by telemetric measurements that stress such as heat exposure, handling, restraint, or even the presence of a colonic temperature probe would promote significant increases in T_{core} in SHR (Berkey et al., 1990; Morley et al., 1990), which was reinforced in recent experiments showing the inability of SHR to deal with exercise-induced hyperthermia (Campos et al., 2014; Drummond et al., 2019; Drummond et al., 2016). Thus, taken together these studies point to impaired thermoregulatory control in SHR in stressed conditions.

In addition, the declines observed in cardiovascular function and responses to thermal challenge during aging may further affect thermal balance in SHR. As in humans, hypertension in SHR is sequentially established as pre-hypertensive, developing and sustained phases (Doggrell and Brown, 1998). Also, it has been proposed that the aging SHR is a model of the transition from stable compensated hypertrophy to heart failure (Boluyt et al., 1995), presenting increased cardiac output alongside with normal total peripheral resistance in the earlier stages of the disease (Smith and Hutchins, 1979). This condition changes as the disease progresses, with hypertrophy of blood vessels leading to increased total peripheral resistance and the cardiac output values returning to normal

(Smith and Hutchins, 1979). Moreover, SHR also presents endothelial dysfunction (Kerr et al., 1999), sympathetic hyperactivity (Judy et al., 1976) and decreased baroreceptor sensitivity (Andresen and Yang, 1989). Overall, these changes may help to explain the increased T_{core} stress-related seen in SHR.

T_{core} , as well as blood pressure, works under a circadian pattern, which enables mammalian animals to adapt to predictable changes in the environment and known behavior such as the light/dark and activity/rest cycles (Golombek and Rosenstein, 2010; Refinetti, 2003). This circadian pattern is ruled by the suprachiasmatic nucleus as the central clock, and is supported by peripheral ones (Chen and Yang, 2015; Golombek and Rosenstein, 2010). This machinery is supposed to be threatened by the aging process and the presence of clinical conditions (Gordon, 2008; Halberg et al., 1981; Refinetti et al., 1990). Regarding aging SHR and despite the fact that many previous studies have evaluated the inability of SHR to regulate T_{core} in stressful situations, no previous study has evaluated the circadian rhythm of T_{core} in these animals. Information is available about other experimental models. For example, a previous study observed a reduction of amplitude and an advancement of acrophase on T_{core} in 14 month-old stroke-prone hypertensive rats (Halberg et al., 1981). However, the stroke-prone SHR are a substrain of hypertensive animals which are most used for stroke incidence studies (Doris, 2017), while the SHR strain is actually the model for essential hypertension (Okamoto and Aoki, 1963). Furthermore, a day-light elevation in T_{core} was found in aging Brown Norway Rats which appears at 8 months of age and persists until 24-months of age in these rats (Gordon, 2008). This elevation was also observed in senescent 21-month-old rats compared to adult 9-month-old rats (Gordon et al., 2014). The authors suggested that T_{core} would be an important physiological biomarker of age in this strain. Therefore, the study of how hypertension and aging influence the circadian rhythm of T_{core} should also be done in senescent SHR.

The SHR originated from a WKY strain in Kyoto-Japan in 1963 and WKY is the inbreed control of SHR (Okamoto and Aoki, 1963). However, WKY present some limitations, including left ventricle hypertrophy without hypertension and elevated blood pressure (Aiello et al., 2004; Altura et al., 1980; Widimsky et al., 1991). Given this, the literature points to extensive use of normotensive WKY and Wistar (WIS) rats for SHR control without considering which strain would be a better or even an inappropriate control to study the T_{core} circadian rhythm in SHR.

Therefore, the present study evaluated the T_{core} circadian rhythm in SHR across aging and compared it to the most used control strains (WIS and WKY). We hypothesized that aging and hypertension could lead to deleterious losses in the circadian rhythm of SHR. In addition, we also tested the hypothesis whether there are possible differences between WIS and WKY compared to SHR animals across aging.

2. Materials and methods

2.1. Sample

The sample was composed by three groups of Wistar (WIS), Wistar Kyoto (WKY) and Spontaneously Hypertensive Rats (SHR). The two normotensive strains (i.e. WIS and WKY) were used to test the hypothesis that there would be no differences between the use of WIS or WKY as SHR controls. In addition, these groups were subdivided into three age groups to test the hypothesis that aging and hypertension could lead to deleterious losses in the circadian rhythm of SHR, namely: 1) WIS16 – Wistar at 16 weeks of age; 2) WIS48 – Wistar at 48 weeks of age; 3) WIS72 – Wistar at 72 weeks of age; 4) WKY: WKY16 – Wistar Kyoto at 16 weeks of at; 5) WKY48 – Wistar Kyoto at 48 weeks of age; 6) WKY72 – Wistar Kyoto at 72 weeks of age; 7) SHR: SHR16 – Spontaneously Hypertensive Rats at 16 weeks of age; 8) SHR48 – Spontaneously Hypertensive Rats at 48 weeks of age; and 9) SHR72 – Spontaneously Hypertensive Rats at 72 weeks of age.

The animals were housed in collective cages (five per cage) and allocated in a controlled environment with light/dark cycle (12/12h), temperature at 22 ± 2 °C, and had free access to food and water (*ad libitum*). The animals were obtained from the central animal house of the Federal University of Viçosa-UFV.

The project was approved by the Animal Use Ethics Commission (CEUA-UFV) of the UFV (Protocol 08/2018) and was conducted in accordance with the principles of the Guide for Care in the Use of Laboratory Animals (Neves et al., 2013).

2.2. Blood pressure and body mass

Body mass (g) was obtained using an electronic scale (Rochelle, model 3252). Systolic blood pressure (SBP; mmHg) and diastolic blood pressure (DBP; mmHg) were measured using the non-invasive method of tail plethysmography (LE5001; Panlab, Barcelona- Spain), as previously described (Byrom and Wilson, 1938). Before the measurements the animals were adapted to a plethysmograph transducer and cuff during

five consecutive days (10 min per day). Mean arterial pressure (MAP; mmHg) was calculated using the following equation: $DBP + 1/3(SBP-DBP)$.

2.3. *T_{core} measurement*

The animals underwent a temperature sensor implant surgery (G2 E-Mitter, model E4000, Starr-Life Science Corp. - USA) for T_{core} (°C) measurement. Inhalation anesthesia was applied (1.5% Isoflurane and 100% O₂ at a constant flow of 1L/min; Isoflurane, BioChimico, RJ, Brazil). After inducing anesthesia, the animal was positioned in dorsal decubitus on a properly heated platform in order to avoid anesthesia-induced hypothermia. Trichotomy and asepsis (Iodopovidone, 10%) were performed in the abdominal region, followed by a ventral incision of approximately 2 cm on the skin and the linea alba of the rectus abdominis muscle. The sensor was implanted in the intraperitoneal cavity and fixed on muscle fascia. Finally, muscle and skin were sutured and a new asepsis was performed. The animals received a 0.07 mL dose of antibiotic (Chemitritil Injectable 2.5%; Chemitec) and 0.01 mL of anti-inflammatory (Flunixin Injectable; Chemitec) immediately after the surgical procedure, and new doses were applied after 12 and 24 hours. The animals were separated into individual cages after surgery and underwent a recovery period of five days, which was sufficient to the complete pre-surgical body mass recovery.

The signals emitted by the implanted sensor were received by a telemetric plate (ER-4000 Energizer/Receiver, Starr-Life Science Corp. - USA) and transmitted to a computer via VitalView software (VitalView® Data Acquisition System Software v. 4.0, Starr-Life Science Corp. - USA).

2.4. *Circadian rhythm measurement*

The T_{core} circadian rhythm was measured over three consecutive days (72 hours) after surgery recovery, as previously described (Machado et al., 2015). T_{core} was recorded every minute and the resulting mean over three days was obtained and shown as a typical 24-hour register day. Data were averaged in 1-h blocks and analyzed using the cosinor method (Refinetti et al., 2007). Each data series was analyzed by a single cosinor involving the least-squares fit of a 24-h COSINE curve. The following rhythm parameters were obtained: the MESOR (°C), a rhythm-adjusted mean; the circadian amplitude (°C), a measure of the extent of variation within a day; the circadian acrophase (h:min), a timing measure of the overall highest values obtained; and the percent rhythm, a measure

of the rhythm strength that reflects the proportion of the total variance in the raw data accounted for by the sinusoidal wave.

2.5. Statistics

The Shapiro-Wilk test was used to analyze data normality. Body mass, SBP, DBP, MAP and cosinor results were analyzed via two-way ANOVA, followed by Bonferroni post-hoc. The T_{core} circadian rhythm was analyzed via repeated measures two-way ANOVA, followed by Bonferroni post-hoc. A paired t-test was used to compare T_{core} during the day and night moments. The Eta squared effect size was calculated for the chronobiology results using the eta squared (η^2) method and classified as: small effect (0.10 to 0.30); medium effect (> 0.30 to 0.50); and large effect (> 0.50) (Cohen, 1988). A 5% alpha was adopted. Data are presented as mean \pm SD.

3. Results

Figure 1 shows the body mass results. Both strain and aging effects were observed. SHR and WKY presented lower body mass compared to WIS at all ages ($p < 0.05$). WKY and SHR exhibited an increased body mass at the ages of 48 and 72 weeks compared to measurements at the age of 16 weeks ($p < 0.05$).

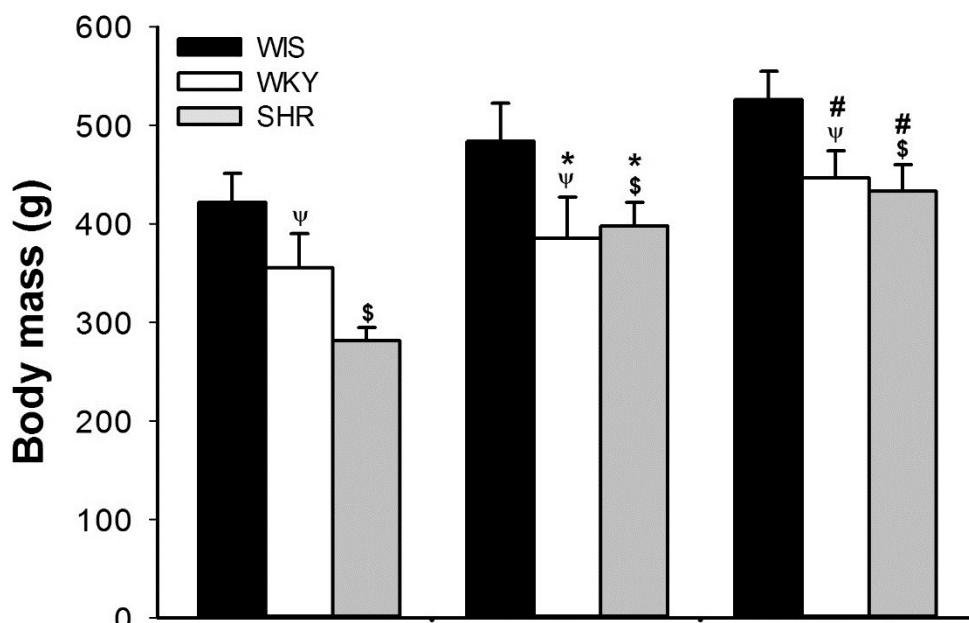

Figure 1. Body mass. WIS: Wistar; WKY: Wistar Kyoto; SHR: Spontaneously Hypertensive Rats. ^Ψ WKY vs. WIS; ^{\$} SHR vs. WIS; [#] 72 vs. 16; ^{*} 48 vs. 16. Data are presented as mean \pm SD of 8 animals per group; $p < 0.05$.

Figure 2 shows the SBP, DBP and MAP results. Both strain and aging effects were observed. SHR presented higher values regarding SBP (Fig. 2A) than WIS and WKY at all ages ($p < 0.05$). WKY48 had higher SBP compared to WIS48. In addition, SHR48 and WKY48 showed higher DBP values (Fig. 2B) than WIS48 ($p < 0.05$). The SHR72 animals exhibited higher DBP compared to WIS72 and WKY72 ($p < 0.05$); and compared to SHR16 and SHR48 ($p < 0.05$). Moreover, SHR16 presented higher MAP values (Fig. 2C) than WIS16 ($p < 0.05$), while SHR48 and SHR72 showed higher values compared to WIS48 and WIS72 and WKY48 and WKY ($p < 0.05$), respectively. The SHR48 and SHR72 groups exhibited an increased MAP compared to SHR16 ($p < 0.05$).

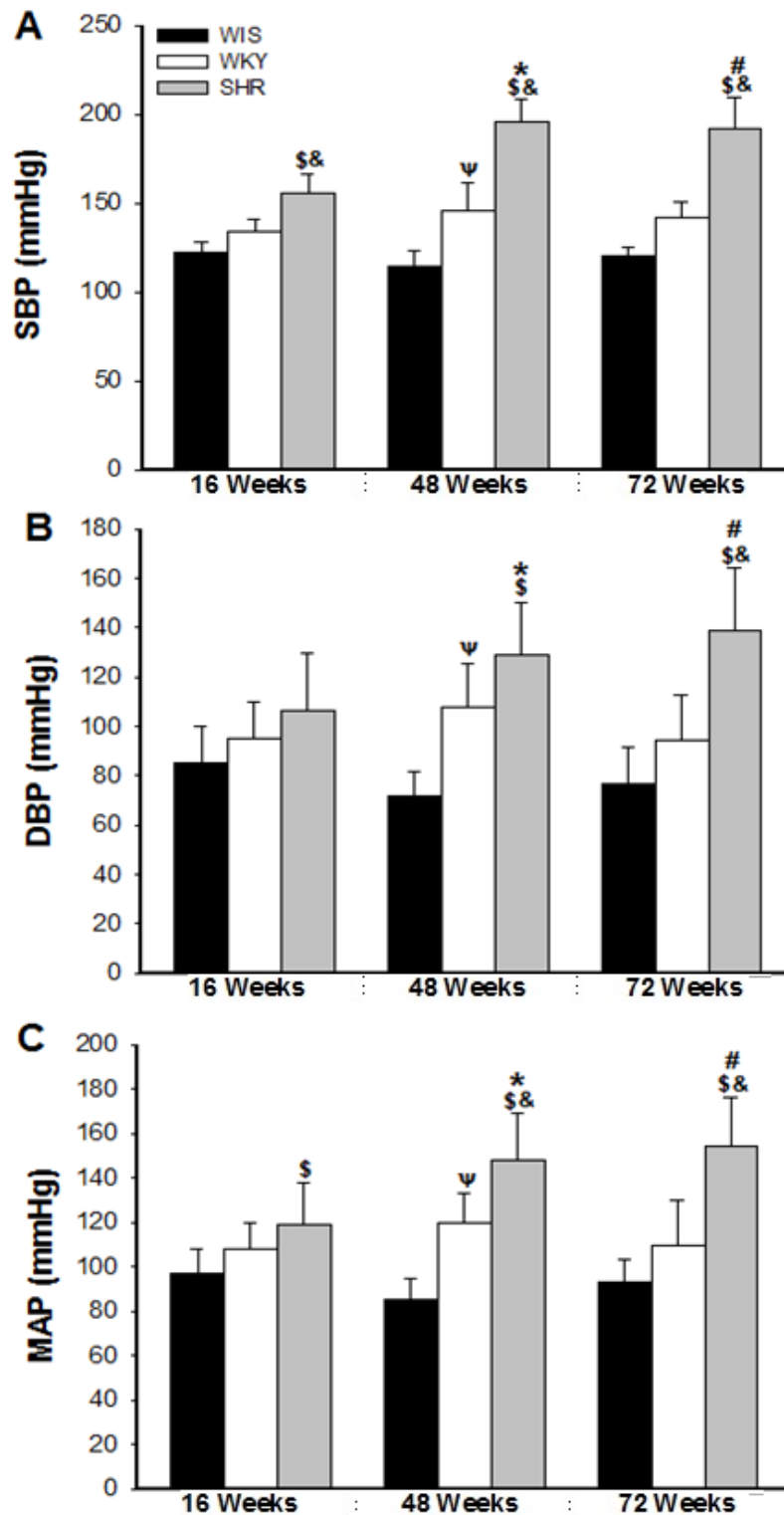

Figure 2. Blood pressure. SBP: Systolic Blood Pressure; DBP: Diastolic Blood Pressure; MAP: Mean Arterial Pressure; WIS: Wistar; WKY: Wistar Kyoto; SHR: Spontaneously Hypertensive Rats. Ψ = WKY vs. WIS; & = SHR vs. WKY; # = 72 vs. 16; * = 48 vs. 16. Data are presented as mean of 8 animals per group \pm SD; $p < 0.05$.

Figure 3 shows the strain and age results (panels A, B and C) analysis on the T_{core} circadian rhythm. SHR16 presented a higher T_{core} than WIS16 (06am to 06pm; 04 and 05am) and WKY16 (07am to 06pm) (Fig. 3A; $p < 0.05$). Both WIS16 and WKY16 showed a significant and sustained T_{core} increase in the activity period (6pm-02am; $p < 0.05$) over 24 hours (not pointed in the figure), and a decrease starting at 02am for WIS16 and at 05am for WKY16. On the other hand, SHR16 showed an earlier and shortened increase (05-08pm; $p < 0.05$). No differences were observed between the strains at the ages of 48 and 72 weeks ($p > 0.05$). The intragroup analysis showed that WIS48 exhibited increased and less sustained T_{core} values in the activity period (06pm-11pm), showing a decrease after 00pm ($p < 0.05$). WKY48 presented a sustained increase in the activity period (06 pm-02am), with a subsequent decrease after 03am ($p < 0.05$). SHR48 showed an inconsistent increase in the activity period ($p < 0.05$). Among 72 week-old animals, T_{core} increased in the activity period in the WIS (07pm-03am; $p < 0.05$) and WKY (06pm-02am; $p < 0.05$) groups, but not in the SHR.

A higher T_{core} was found when observing the aging analysis on the T_{core} circadian rhythm in WIS72 compared to WIS16 (06am; 09am-01pm; 04pm; 07pm; 01-03am; $p < 0.05$) (Fig. 3C). In addition, a higher T_{core} was found in WKY72 than in WKY16 (07-08am; 11-12am; 02pm; 11pm; $p < 0.05$) (Fig. 3C). No age effects were observed in the SHR strain (Fig. 3C; $p > 0.05$).

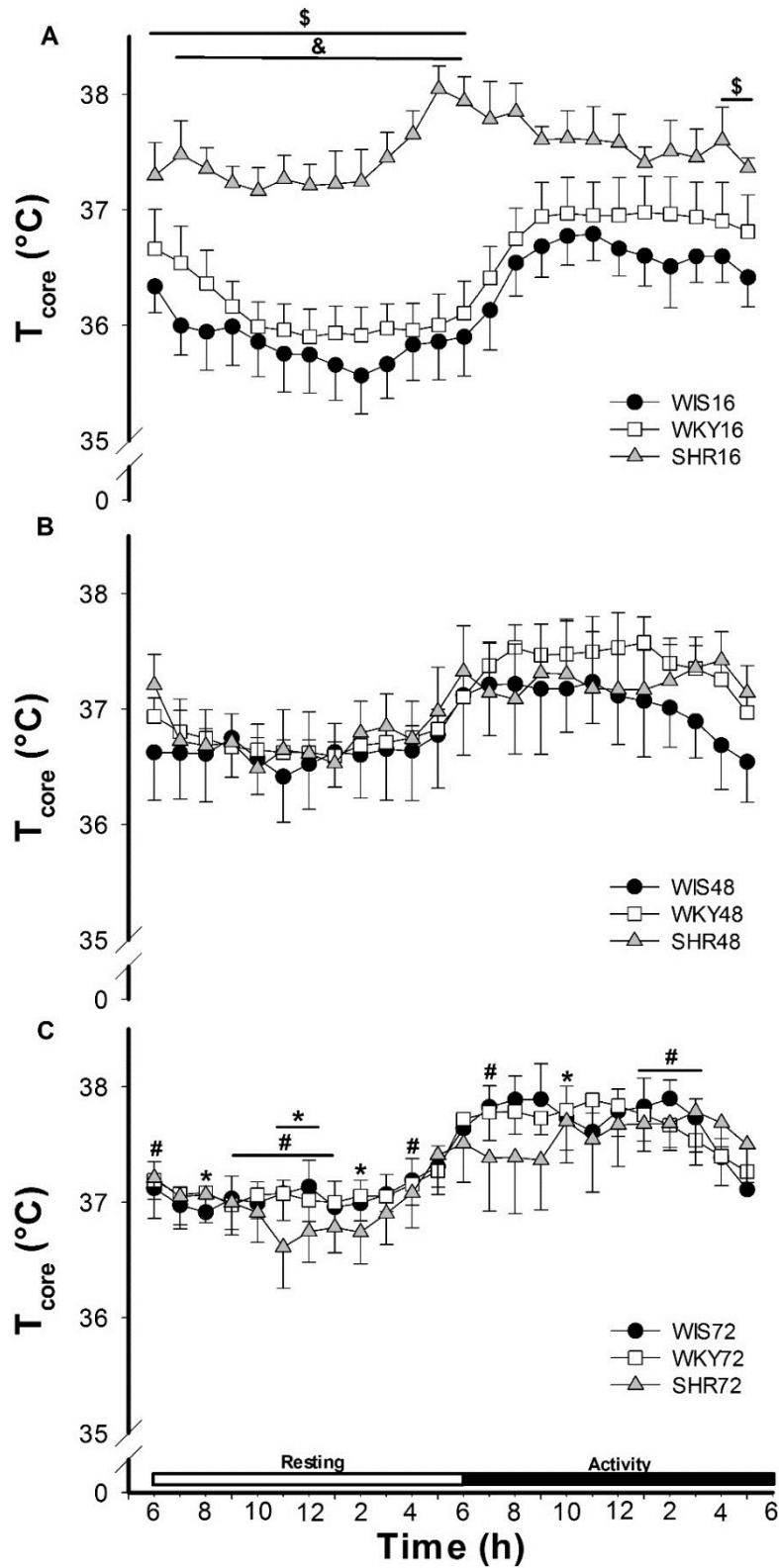

Figure 3. Strain and age analysis on the core temperature (T_{core}) circadian rhythm. WIS16: 16-week-old Wistar; WIS48: 48-week-old Wistar; WIS72: 72-week-old Wistar; WKY16: 16-week-old Wistar Kyoto; WKY48: 48-week-old Wistar Kyoto; WKY72: 72-week-old Wistar Kyoto; SHR16: 16-week-old Spontaneously Hypertensive Rats; SHR48: 48-week-old Spontaneously Hypertensive Rats; SHR72: 72-week-old Spontaneously Hypertensive Rats. \$ = SHR vs. WIS at the same age; & = SHR vs. WKY at the same age; # = WIS72 vs. WIS16; * = WKY72 vs. WKY16. Data are presented as mean \pm SD of 8 animals per group; $p < 0.05$.

Figure 4 shows resting and activity periods analysis on T_{core} . Both strain and aging effects were observed at rest (Fig. 4A). The SHR16 group showed higher T_{core} compared to WIS16 and WKY16 groups ($p < 0.05$). The WIS48 group exhibited higher T_{core} than WIS16 group ($p < 0.05$). Furthermore, the WIS72 and WKY72 groups showed higher T_{core} compared to WIS16 and WKY16, respectively ($p < 0.05$). Finally, no differences were observed in the activity period in all groups (Fig. 4B; $p > 0.05$).

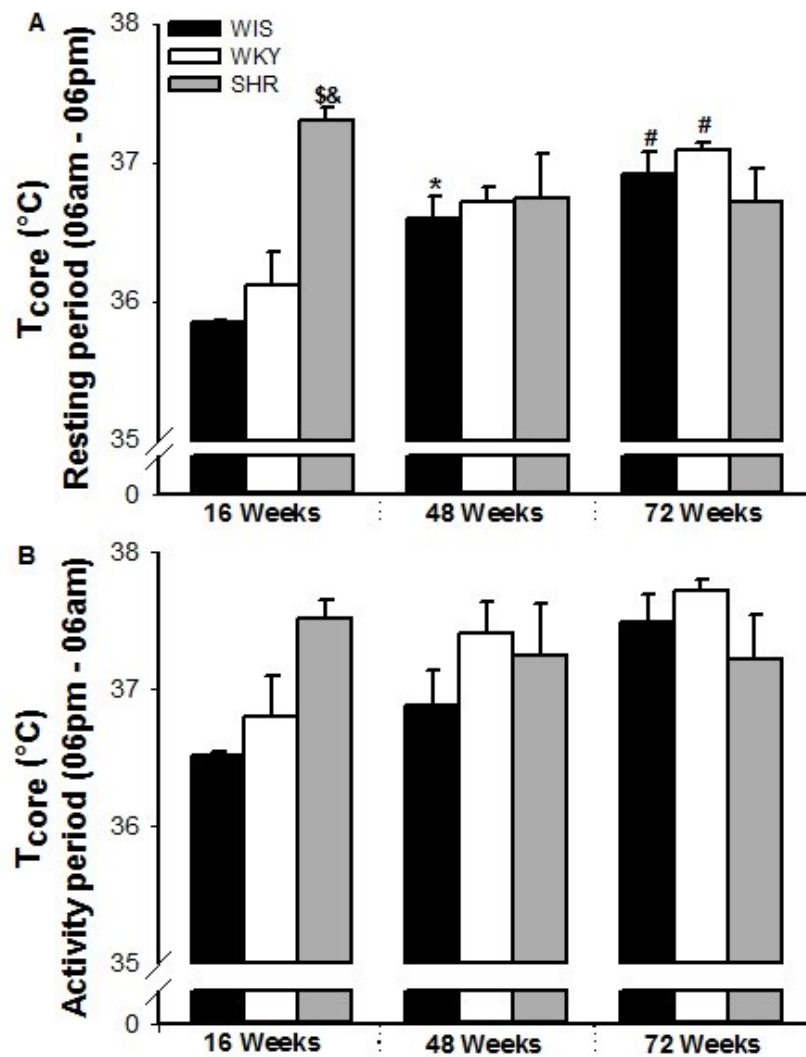

Figure 4. Resting (A) and activity (B) period analysis on core temperature (T_{core}). WIS: Wistar; WKY: Wistar Kyoto; SHR: Spontaneously Hypertensive Rats. \$ = WIS vs. SHR; & = WKY vs. SHR; * = 48 vs. 16; # = 72 vs. 16. Data are presented as mean \pm SD of 8 animals per group; $p < 0.05$.

Table 1 presents the cosine analysis of the T_{core} circadian rhythm. No differences were found for the acrophase ($p > 0.05$; $\eta^2 = 0.37$). An aging effect on the SHR strain was observed regarding amplitude. The SHR72 group presented higher values compared to SHR16 ($p < 0.05$; $\eta^2 = 0.45$). In addition, both strain and aging effects were found concerning MESOR. The SHR16 group had higher values than the WIS16 and WKY16 groups ($p < 0.05$; $\eta^2 = 0.56$). WIS72 and WKY72 showed higher values compared to the WIS16 and WKY16 groups, respectively ($p < 0.05$; $\eta^2 = 0.56$). Lastly, no differences were observed among strains regarding the strength rhythm analysis, indicating that all groups present reliable rhythms ($p > 0.05$; $\eta^2 = 0.46$).

Table 1. Cosinor analysis of the T_{core} circadian rhythm.

<i>WIS16</i>	<i>WKY16</i>	<i>SHR16</i>	<i>WIS48</i>	<i>WKY48</i>	<i>SHR48</i>	<i>WIS72</i>	<i>WKY72</i>	<i>SHR72</i>
<i>Acrophase (h:min)</i>								
23:31 ± 00:53	22:12 ± 03:13	21:06 ± 02:26	23:06 ± 00:39	21:46 ± 05:00	20:54 ± 06:45	23:39 ± 00:25	23:37 ± 00:25	19:53 ± 00:25
<i>Amplitude (°C)</i>								
0.51 ± 0.15	0.54 ± 0.26	0.33 ± 0.09	0.44 ± 0.10	0.56 ± 0.20	0.45 ± 0.13	0.47 ± 0.15	0.44 ± 0.22	0.48 ± 0.08 [#]
<i>MESOR (°C)</i>								
36.50 ± 0.75	36.44 ± 0.74	37.49 ± 0.08 [§] &	36.83 ± 0.38	37.05 ± 0.41	37.26 ± 0.61	37.38 ± 0.11 [#]	37.38 ± 0.11 [#]	37.26 ± 0.62
<i>Percent rhythm (%R)</i>								
83.02 ± 6.21	71.12 ± 32.10	56.87 ± 12.19	68.26 ± 11.30	84.34 ± 17.39	71.65 ± 20.31	77.68 ± 3.79	81.17 ± 15.10	77.13 ± 7.83

*WIS16: 16-week-old Wistar (n=8); WIS48: 48-week-old Wistar (n=7); WIS72: 72-week-old Wistar (n=6); WKY16: 16-week-old Wistar Kyoto (n=8); WKY48: 48-week-old Wistar Kyoto (n=7); WKY72: 72-week-old Wistar Kyoto (n=7); SHR16: 16-week-old Spontaneously Hypertensive Rats (n=6); SHR48: 48-week-old Spontaneously Hypertensive Rats (n=6); SHR72: 72-week-old Spontaneously Hypertensive Rats (n=6).[§] = SHR vs. WIS; & = SHR vs. WKY; * = 48 vs. 16; # = 72 vs. 16. Data are presented as mean ± SD; p<0.05.*

4. Discussion

The present study evaluated the T_{core} circadian rhythm in SHR across aging and compared it to both WIS and WKY as normotensive controls. Our first hypothesis assessed whether a combination of aging and hypertension could lead to deleterious losses in the circadian rhythm of T_{core} in SHR. We observed a progressive and similar change in the circadian rhythm of both WIS and WKY, with the hypertension factor only influencing the circadian rhythm of 16-week-old SHR. Additionally, as our second hypothesis, our results showed that these two strains were found to be appropriate to be used as controls for SHR considering thermoregulatory studies regarding the T_{core} circadian rhythm. However, caution needs to be taken when choosing between them. We observed that the WIS strain presented higher body mass and blood pressure values closer to normotension than WKY over time. On the other hand, despite body mass values being similar to SHR, WKY presented blood pressure values closer to the hypertension borderline.

4.1. Circadian rhythm of T_{core} in SHR across aging

The results of the present study showed that hypertension and aging combination, except at the age of 16 weeks, did not lead to marked losses in T_{core} circadian rhythm in SHR. The percent rhythm indicates the circadian rhythm strength, however, there are no cut-off points for this analysis (Refinetti et al., 2007). Thus, it is necessary to establish a comparison based on the study controls. Although there is a hypertension effect on the T_{core} circadian rhythm of 16-week-old rats, our results indicate that there is no loss of rhythm induced by either aging or disease. In fact, it was observed that the youngest SHR (16 weeks-old) presented higher MESOR T_{core} results in relation to WIS and WKY at the same age. Such differences were supported by higher T_{core} results especially observed in the resting period at 16 weeks of age (Fig. 3A). However, this disturbance among groups disappeared at the ages of 48 (Fig. 3B) and 72 weeks (Fig. 3C). Similar results were found in Brown Norway Rats and F344 rats in which aging induced a T_{core} increase (Gordon, 2008; Kiang-Ulrich and Horvath, 1984). Interestingly, the temperature curves in SHR were similar in the three ages evaluated (Fig. 3A, B and C), indicating that hypertensive animals already present this thermoregulatory change at 16 weeks of age.

The scientific literature shows that 16 weeks is a critical moment in the SHR development (Adams et al., 1989; Bing et al., 1995; Boluyt et al., 1995). Previous studies from our laboratory (Campos et al., 2014; Drummond et al., 2019; Drummond et al., 2016) and elsewhere (O'Donnell and Volicer, 1981; Berkey et al., 1990; Morley et al., 1990) have

consistently shown higher T_{core} values in SHR submitted to stress challenges. Regarding the issue of hypertension, it is particularly important to mention that brain temperature has also been found to be increased in 16-week-old SHR (Drummond et al., 2016). Thus, the SHR has a well-established pre-hypertensive stage before reaching this age and present a vessel-related hypertrophic process approximately by the 4th week, but with normal SBP (Adams et al., 1989). This pre-hypertensive stage lasts approximately until the 16th week of life, the moment from which the compensated hypertension stage in the SHR sets in, as characterized by SBP values above 150mmHg (Doggrell and Brown, 1998). The structural rearrangements which occur in the heart and blood vessels at this moment in order to maintain cardiac function (Bing et al., 1995; Grossman, 1980) are also known to affect thermoregulation in these animals (Folkow et al., 1970).

Surprisingly, we observed an increase in the circadian rhythm amplitude with medium effect size in the SHR group over time (Table 1). The amplitude of the circadian rhythm is usually measured by the intersection between acrophase and MESOR (Cornelissen, 2014; Refinetti et al., 2007). The highest results of T_{core} observed in the resting period in the SHR16 group was possibly responsible for the approximation between MESOR and acrophase and consequently for the amplitude reduction in the 16th, but not in the 48th and 72nd week of age.

Understanding the effects of hypertension on thermal homeostasis is very important inasmuch as the cardiovascular system is essential to maintain T_{core} , mainly through the vascular tonus control (Gonzalez-Alonso et al., 2008; Lewis et al., 1986; O'Donnell and Volicer, 1981). Caudal artery vasodilatation in rats represents a point of extreme importance for heat dissipation, since this is the only region free from hair, and its shape additionally has a large surface area to volume ratio, favoring the heat exchange with the environment (Rand et al., 1965). However, evidence indicates that SHR present resistance to blood flow through the tail, which occurs due to functional and morphological alterations in the small peripheral arteries. This results in limited vasodilation, thus contributing to a reduction in heat dissipation capacity and consequently to higher heat storage (Folkow et al., 1970; O'Leary and Wang, 1994).

Interestingly and contrary to our hypothesis, despite the fact that the SHR presented an unstable rhythm at all evaluated ages, the aging effects were similar among the groups; therefore, there were no effects of hypertension at the 48th and 72nd weeks (Fig. 3B and C). Even when free of diseases, aging is usually accompanied by a decline in several bodily functions, which includes structural and functional changes in the cardiovascular system (Ferrari, 2002). Evidence points out that aging promotes an increase in heart mass due to

ventricular hypertrophy (Miller et al., 1986). As in the heart, the vessels also undergo hypertrophy and lose elasticity, becoming more stiff, leading to loss of function and causing problems such as peripheral vascular resistance increases (Ferrari, 2002). Additionally, a previous study involving aging Brown Norway Rats suggested that aging can promote dysfunction in the circadian pacemaker (Gordon, 2008).

The current findings may reflect a specific transition condition from pre-hypertensive and hypertensive stage around 16 weeks of age in these animals which changes their circadian thermoregulation pattern. Future studies should be conducted attempt to understand the causes of this specific change, which may favor better understanding of the hypertension model and will surely contribute to advance the knowledge involving thermal regulation and hypertension development.

4.2. Which strain (WIS or WKY) is the more appropriate control for SHR in studies on the T_{core} circadian rhythm?

The results of the present study indicate that both the WIS and WKY strains are appropriate to be used as controls for SHR. However, choosing one should be well planned and done with caution since higher results of body mass (Fig. 1) and pressure values (Fig. 2A) closer to those indicated for the normotension were found in the WIS strain. On the other hand, the WKY strain presented closer body mass values to SHR and blood pressure results closer to the hypertension borderline. This might influence the difference between groups considering variables related with obesity, such as inflammation (Nishimura et al., 2009).

Previous reports have indicated that the basal metabolic rate of mammals is strongly influenced by both body mass and body temperature (Gillooly et al., 2001). We found that the body mass values of the WKY group were closer to those of SHR compared to those of the WIS group. Moreover, the ANOVA and cosinor analysis pointed to similar behavior in the normotensive groups at all ages. These animals presented consistent increases in T_{core} between 06pm and 02Am in the 16th week. Interestingly, both normotensive groups showed an increase in T_{core} in the 48th and 72nd weeks, as indicated by higher MESOR and large effect size results.

No differences were observed in this study when comparing T_{core} values between WIS and WKY groups, although the WKY group presented high blood pressure values compared to the WIS group. Thus, it is conceivable that the blood pressure difference in this case is not large enough to cause changes in thermoregulatory control, since the homeostatic control is prominent over the circadian control (Refinetti, 2010). According to Okamoto and Aoki (1963),

rats can be classified as hypertensive when presenting SBP values above 150 mmHg (Okamoto and Aoki, 1963). Thus, the groups used in the present study were classified as follows (SBP/DBP): WIS16 = normotensive (122.0/85.0 mmHg); WKY16 = normotensive (132.5/95.0 mmHg); SHR16 = hypertensive (155.7/106.0 mmHg); WIS48 = normotensive (115.0/71.8 mmHg); WKY48 = normotensive (145.87/107.75 mmHg); SHR48 = hypertensive (195.87/128.87 mmHg); WIS72 = normotensive (120.5/76.5 mmHg); WKY72 = normotensive (142.12/94.2 mmHg); SHR72 = hypertensive (192.12/138.7 mmHg). Thus, although the WKY strain presented higher values compared to WIS, they showed regular SBP values, which associated with similar T_{core} circadian rhythm results confirms its widespread use as a control for SHR in thermoregulation research.

5. Conclusions

SHR present worse thermoregulatory control at 16 weeks of age on the rhythm-adjusted T_{core} mean, while other circadian rhythm parameters were not different in hypertensive animals across aging. In addition, our results showed that both the WIS and WKY strains are appropriate as normotensive controls for SHR in experiments aimed to evaluate the T_{core} circadian rhythm.

6. Acknowledgments

This study was supported by grants from *CNPq (Conselho Nacional de Desenvolvimento Científico e Tecnológico)*, *CAPES (Coordenação de Aperfeiçoamento de Pessoal de Nível Superior)* and *FAPEMIG (Fundação de Amparo à Pesquisa do Estado de Minas Gerais)*.

7. References

- Adams, M.A., Bobik, A., Korner, P.I., 1989. Differential development of vascular and cardiac hypertrophy in genetic hypertension. Relation to sympathetic function. *Hypertension* 14, 191-202.
- Aiello, E.A., Villa-Abrille, M.C., Escudero, E.M., Portiansky, E.L., Perez, N.G., de Hurtado, M.C., Cingolani, H.E., 2004. Myocardial hypertrophy of normotensive Wistar-Kyoto rats. *Am J Physiol Heart Circ Physiol* 286, H1229-1235.
- Altura, B.M., Carella, A., Altura, B.T., 1980. Magnesium ions control prostaglandin reactivity of venous smooth muscle from spontaneously hypertensive rats. *Prostaglandins Med* 4, 255-261.
- Andresen, M.C., Yang, M., 1989. Arterial baroreceptor resetting: contributions of chronic and acute processes. *Clin Exp Pharmacol Physiol Suppl* 15, 19-30.
- Argaud, L., Ferry, T., Le, Q.H., Marfisi, A., Ciorba, D., Achache, P., Ducluzeau, R., Robert, D., 2007. Short- and long-term outcomes of heatstroke following the 2003 heat wave in Lyon, France. *Arch Intern Med* 167, 2177-2183.
- Berkey, D.L., Meeuwse, K.W., Barney, C.C., 1990. Measurements of core temperature in spontaneously hypertensive rats by radiotelemetry. *Am J Physiol* 258, R743-749.
- Bing, O.H., Brooks, W.W., Robinson, K.G., Slawsky, M.T., Hayes, J.A., Litwin, S.E., Sen, S., Conrad, C.H., 1995. The spontaneously hypertensive rat as a model of the transition from compensated left ventricular hypertrophy to failure. *J Mol Cell Cardiol* 27, 383-396.
- Boluyt, M.O., Bing, O.H., Lakatta, E.G., 1995. The ageing spontaneously hypertensive rat as a model of the transition from stable compensated hypertrophy to heart failure. *Eur Heart J* 16 Suppl N, 19-30.
- Byrom, F.B., Wilson, C., 1938. A plethysmographic method for measuring systolic blood pressure in the intact rat. *J Physiol* 93, 301-304.
- Campos, H.O., Leite, L.H.R., Drummond, L.R., Cunha, D.N.Q., Coimbra, C.C., Natali, A.J., Primola-Gomes, T.N., 2014. Temperature Control of Hypertensive Rats during Moderate Exercise in Warm Environment. *J Sport Sci Med* 13, 695-701.
- Chen, L., Yang, G., 2015. Recent advances in circadian rhythms in cardiovascular system. *Front Pharmacol* 6, 71.
- Cohen, J.I., 1988 *Statistical power analysis for the behavioral sciences*. Hillsdale.
- Collins, M.G., Hunter, W.S., Blatteis, C.M., 1987. Factors producing elevated core temperature in spontaneously hypertensive rats. *J Appl Physiol* (1985) 63, 740-745.
- Cornelissen, G., 2014. Cosinor-based rhythmometry. *Theor Biol Med Model* 11, 16.
- Doggrell, S.A., Brown, L., 1998. Rat models of hypertension, cardiac hypertrophy and failure. *Cardiovascular Research* 39, 89-105.
- Doris, P.A., 2017. Genetics of hypertension: an assessment of progress in the spontaneously hypertensive rat. *Physiol Genomics* 49, 601-617.
- Drummond, L.R., Kunstetter, A.C., Campos, H.O., Vaz, F.F., Drummond, F.R., Andrade, A.G.P., Coimbra, C.C., Natali, A.J., Wanner, S.P., Primola-Gomes, T.N., 2019. Spontaneously hypertensive rats have greater impairments in regulating abdominal temperature than brain cortex temperature following physical exercise. *Journal of Thermal Biology* 83, 30-36.
- Drummond, L.R., Kunstetter, A.C., Vaz, F.F., Campos, H.O., Andrade, A.G., Coimbra, C.C., Natali, A.J., Wanner, S.P., Primola-Gomes, T.N., 2016. Brain Temperature in Spontaneously Hypertensive Rats during Physical Exercise in Temperate and Warm Environments. *Plos One* 11, e0155919.
- Ellis, F.P., 1972. Mortality from heat illness and heat-aggravated illness in the United States. *Environ Res* 5, 1-58.
- Ferrari, A.U., 2002. Modifications of the cardiovascular system with aging. *Am J Geriatr Cardiol* 11, 30-33.
- Folkow, B., Hallback, M., Lundgren, Y., Weiss, L., 1970. Structurally based increase of flow resistance in spontaneously hypertensive rats. *Acta Physiol Scand* 79, 373-378.
- Gillooly, J.F., Brown, J.H., West, G.B., Savage, V.M., Charnov, E.L., 2001. Effects of size and temperature on metabolic rate. *Science* 293, 2248-2251.

- Golombek, D.A., Rosenstein, R.E., 2010. Physiology of circadian entrainment. *Physiol Rev* 90, 1063-1102.
- Gonzalez-Alonso, J., Crandall, C.G., Johnson, J.M., 2008. The cardiovascular challenge of exercising in the heat. *J Physiol* 586, 45-53.
- Gordon, C.J., 2008. Cardiac and thermal homeostasis in the aging Brown Norway rat. *J Gerontol A Biol Sci Med Sci* 63, 1307-1313.
- Gordon, C.J., Johnstone, A.F., Aydin, C., Phillips, P.M., MacPhail, R.C., Kodavanti, U.P., Ledbetter, A.D., Jarema, K.A., 2014. Episodic ozone exposure in adult and senescent Brown Norway rats: acute and delayed effect on heart rate, core temperature and motor activity. *Inhal Toxicol* 26, 380-390.
- Grossman, W., 1980. Cardiac hypertrophy: useful adaptation or pathologic process? *Am J Med* 69, 576-584.
- Halberg, J., Halberg, E., Regal, P., Halberg, F., 1981. Changes with age characterize circadian rhythm in telemetered core temperature of stroke-prone rats. *J Gerontol* 36, 28-30.
- Judy, W.V., Watanabe, A.M., Henry, D.P., Besch, H.R., Jr., Murphy, W.R., Hockel, G.M., 1976. Sympathetic nerve activity: role in regulation of blood pressure in the spontaneously hypertensive rat. *Circ Res* 38, 21-29.
- Kerr, S., Brosnan, M.J., McIntyre, M., Reid, J.L., Dominiczak, A.F., Hamilton, C.A., 1999. Superoxide anion production is increased in a model of genetic hypertension: role of the endothelium. *Hypertension* 33, 1353-1358.
- Kiang-Ulrich, M., Horvath, S.M., 1984. Age-related metabolic modifications in male F344 rats. *Exp Aging Res* 10, 89-93.
- Lewis, S.J., Maccarrone, C., Jarrott, B., 1986. Modification of the circadian body temperature rhythm of the spontaneously hypertensive rat during and following cessation of continuous clonidine infusion. *Brain Res* 385, 383-388.
- Machado, F.S., Rodovalho, G.V., Coimbra, C.C., 2015. The time of day differently influences fatigue and locomotor activity: is body temperature a key factor? *Physiol Behav* 140, 8-14.
- Miller, T.R., Grossman, S.J., Schectman, K.B., Biello, D.R., Ludbrook, P.A., Ehsani, A.A., 1986. Left ventricular diastolic filling and its association with age. *Am J Cardiol* 58, 531-535.
- Morley, R.M., Conn, C.A., Kluger, M.J., Vander, A.J., 1990. Temperature regulation in biotelemetered spontaneously hypertensive rats. *Am J Physiol* 258, R1064-1069.
- Neves, S.M.P., Ong, F.M.P., Rodrigues, L.D., Santos, R.A., Fontes, R.S., Santana, R.O., 2013. *Manual de Cuidados e Procedimentos com Animais de Laboratório do Biotério de Produção e Experimentação da FCF-IQ/USP*, São Paulo.
- Nishimura, S., Manabe, I., Nagai, R., 2009. Adipose tissue inflammation in obesity and metabolic syndrome. *Discov Med* 8, 55-60.
- Nybo, L., Kjellstrom, T., Bogataj, L.K., Flouris, A.D., 2017. Global heating: Attention is not enough; we need acute and appropriate actions. *Temperature (Austin)* 4, 199-201.
- O'Donnell, A., Volicer, L., 1981. Thermoregulation in spontaneously hypertensive rats: effects of antihypertensive treatments. *Clin Exp Hypertens* 3, 555-567.
- O'Leary, D.S., Wang, G., 1994. Impaired thermoregulatory cutaneous vasodilation in spontaneously hypertensive rats. *J Appl Physiol* (1985) 77, 692-696.
- Okamoto, K., Aoki, K., 1963. Development of a strain of spontaneously hypertensive rats. *Jpn Circ J* 27, 282-293.
- Rand, R.P., Burton, A.C., Ing, T., 1965. The Tail of the Rat, in *Temperature Regulation and Acclimatization*. *Can J Physiol Pharmacol* 43, 257-267.
- Refinetti, R., 2003. Metabolic heat production, heat loss and the circadian rhythm of body temperature in the rat. *Exp Physiol* 88, 423-429.
- Refinetti, R., 2010. The circadian rhythm of body temperature. *Front Biosci (Landmark Ed)* 15, 564-594.
- Refinetti, R., Lissen, G.C., Halberg, F., 2007. Procedures for numerical analysis of circadian rhythms. *Biol Rhythm Res* 38, 275-325.

- Refinetti, R., Ma, H., Satinoff, E., 1990. Body temperature rhythms, cold tolerance, and fever in young and old rats of both genders. *Exp Gerontol* 25, 533-543.
- Smith, T.L., Hutchins, P.M., 1979. Central hemodynamics in the developmental stage of spontaneous hypertension in the unanesthetized rat. *Hypertension* 1, 508-517.
- Widimsky, J., Kuchel, O., Tremblay, J., Hamet, P., 1991. Distinct plasma atrial natriuretic factor, renin and aldosterone responses to prolonged high-salt intake in hypertensive and normotensive rats. *J Hypertens* 9, 241-247.
- Wilson, J.R., Wilson, L.M., DiCarra, I.V., 1977. Evidence for an elevation in thermoregulatory set-point in SHR. In: *Int. Symp. on SHR Spontaneous Hypertension: Its Pathogenesis and Complications* (2nd ed.). Washington, DC: Dept. Health Educ. and Welfare, 1977. (DHEW Publ. No. 77-1179).

CAPÍTULO 4

The Spontaneously Hypertensive Rats had lower heat loss capacity in progressive and continuous exercise protocols.

Leonardo Rezende, Leôncio Soares¹, Filipe Drummond¹, Tiago Leal¹, Anselmo Gomes¹, Lukiya Favarato², Evandro Favarato², Antônio Natali¹, Cândido Coimbra³ e Thales Prímola-Gomes¹.

¹Laboratório de Biologia do Exercício, Departamento de Educação Física, Universidade Federal de Viçosa, Viçosa, MG, Brasil; ²Departamento de Veterinária, Universidade Federal de Viçosa, Viçosa, MG, Brasil; ³Laboratório de Endocrinologia e Metabolismo, Departamento de Fisiologia e Biofísica, Universidade Federal de Minas Gerais, Belo Horizonte, MG, Brasil.

Abstract:

Introduction: Arterial hypertension is among the cardiovascular disorders with the highest prevalence, characterized as multifactorial syndrome with sustained chronic blood pressure increase. Spontaneously Hypertensive Rat (SHR) are widely used as model for essential hypertension researches, with the Wistar (WIS) and Wistar Kyoto (WKY) as main control strains. However, there is a debate in the literature about which strain is more appropriated for this function. **Objective:** the aim of the present study was to evaluate the long-term behavior of thermoregulation responses during maximal test until fatigue (MTF) and continuous test (CT) of SHR and its controls, namely WIS and WKY. **Methods:** Male SHR and WIS rats with 16, 48 and 72 weeks were used. The blood pressure was performed using the noninvasive method of tail plethysmography and the body mass using an electronic scale. Core temperature (T_{core}) was measured every minute by telemetry and skin temperature (T_{skin}) using a thermometer connected to a thermocouple during two exercise protocols: MTF and CT. The performance was measured by workload calculation. **Results:** the WIS strain shown higher workload (J) results, mainly with 16 and 72 weeks. About thermoregulatory adjustments, SHR exhibited lower heat loss capacity with 16 and 48 weeks, and the aging process reduced heat loss capacity of normotensive animals. **Conclusions:** The SHR presented less effective thermoeffector response during exercise. Furthermore, they show an equal response at all ages studied, indicating that at 16 weeks hypertension has already caused serious damage to the thermoregulatory control. Finally, the both normotensive controls can be used as SHR control. However, the WIS strain seems to be more affected to aging process than WKY.

Keywords: Thermoregulation; heat loss capacity; experimental models; hypertension.

1- Introduction:

The cardiovascular diseases have a high incidence, accounting for a large part of the deaths in the world (1). Arterial hypertension is among the cardiovascular disorders with the highest prevalence, characterized as multifactorial syndrome with sustained chronic blood pressure increase (1). Its incidence is often associated with others clinical disorders such as vascular diseases (2), myocardial infarction (3) and renal insufficiency (4). Thus, pathophysiology of arterial hypertension understanding is important, and for this, animals as employs as experimental models (5). Spontaneously Hypertensive Rat (SHR) are widely used as model for essential hypertension researches (5, 6).

It is known that cardiovascular diseases affect the body's thermoregulatory balance, both during rest and physical activities (7-9). Particularly, the control of vascular tonus is critical for the thermoregulatory control, since it directly affects the heat retention and dissipation capacities (10, 11). To observe the response of vascular tonus during exercise in rats, an important tool is the heat loss index (HLI), which indicates the state of vascular constriction (12-14). O'donnell and Volicer (1981) shown that SHR presented less effective thermoregulation capacity during rest and point out the failure of central mechanism control as responsible (7). Also, our group has pointed in last years that hypertensive animals show thermoregulatory impairment during physical exercise, like increased heat production and storage, increased brain temperature, mechanical efficiency reduction and impaired recovery of central temperature (T_{core}) after progressive and continuous exercise (8, 9, 15, 16).

Cardiovascular disorders promoted by hypertension lead to performance impairment (17). Several factor are pointed as responsible, like as peripheral problems, among which are muscular atrophy, greater proportion of type IIA muscle fibers and difficulty of dissipating abdominal heat (15, 18, 19). In addition, evidence points to a reduced mechanical efficiency of SHR in low-intensity aerobic exercise and this is directly associated with higher energy cost and, consequently, higher heat production (16). Together, cardiovascular and peripheral complications can impair the exercise capacity (EC) of SHR.

Although the literature points to loss of performance associated with greater thermoregulatory stress in SHR during both progressive and continuous exercise, no studies analyzed the thermoregulatory responses of SHR and control strains (Wistar-WIS and Wistar Kyoto- WKY) during life aging process (16, 48 and 72 weeks). Thus, the aim of the present study was to evaluate the long-term behavior of thermoregulation responses during maximal test until fatigue (MTF) and continuous test (CT) of SHR and its controls, namely WIS and WKY.

2- Materials and Methods:

Male SHR and WIS rats with 16, 48 and 72 weeks were used. The experimental groups were stratified randomly. The animals were housed in collective cages allocated in a controlled environment with light/dark cycle (12/12h), temperature at 22 ± 2 °C, and had free access to commercial food and water (*ad libitum*). The animals were obtained from central biotery of the Federal University of Viçosa-UFV.

The project was approved by the Animal Use Ethics Commission (CEUA-UFV) of the UFV (Protocol 08/2018) and was conducted in accordance with the principles of the Guide for Care in the Use of Laboratory Animals (20). The procedures were accompanied by a veterinarian.

Blood pressure and body mass:

The animals were adapted to a containment apparatus heated at 29-32 °C for 10 minutes for five consecutive days. Subsequently, systolic blood pressure (SBP), diastolic blood pressure (DBP) and mean arterial pressure (MAP) measurement were performed using the noninvasive method of tail plethysmography (LE5001; Panlab, Barcelona, Spain). The body mass was measured using an electronic scale (Rochelle, model 3252).

Temperature Sensor Implant:

The animals underwent a temperature sensor implant surgery (G2 E-Mitter, model E4000, Mini-Mitter, USA). Inhalation anesthesia was applied (1.5% Isoflurane and 100% O₂ in a constant flow of 1L/min; Isoflurane, BioChimico, RJ, Brazil). After induction of anesthesia, the animal was positioned in dorsal decubitus on a properly heated platform in order to avoid hypothermia induced by anesthetic. The trichotomy and asepsis (Iodopovidone, 10%) were performed in abdominal region, followed by ventral incision of approximately 2 cm on the skin and the line alba of the rectus abdominis muscle. The sensor was implanted in intraperitoneal cavity and fixed on muscle fascia. Finally, the muscle and skin were sutured and new asepsis was performed. Immediately after the surgical procedure the animals received a dose of 0.07 mL of antibiotic (Chemitril Injectable 2.5%; Chemitec) and 0.01 mL of anti-inflammatory (Flunixin Injectable; Chemitec); after 12 and 24 hours, new doses were applied.

Exercise protocols:

Maximal test. The animals were familiarized with a treadmill with 5° of inclination and electrical stimulation during five days, 10 minutes for day. After, each rat was submitted to MTF to determine their EC. The test was started at speed of 10 m/min, with increments of 1 m/min each 3 min until fatigue. The electrical stimulation in treadmill was set to 0.2 mA throughout the exercise period (8, 9, 21), and

the fatigue was defined as the point where animals were no longer able to kept pace with treadmill for 10 seconds (22). All tests were realized in the morning period.

Continuous test. After the MTF, all animals were undergoing a continuous test (CT) with duration of 30 min. The intensity applied was 60% of maximal velocity observed in MTF.

T_{core} was measured by telemetry (ER-4000 energizer/receptor, Mini-Mitter Respironics, USA). Also, skin temperature (T_{skin}) was measured using a thermometer (THR-140, Instrutherm Instruments, Brazil) connected to a thermocouple (S-09K, Instrutherm Instruments, Brazil), using an impermeable adhesive tape at approximately 20 mm from the lateral base of the tail (23). The of T_{core} and T_{skin} results were presented at the moment of fatigue for the progressive test and in the final minute for the continuous test. All tests were performed at room temperature between 23-25 °C.

Calculated variables:

workload (J) by the proposed formula (24): body mass (Kg) x TTE (min) x treadmill speed (m/min) x $\sin\alpha$ (treadmill inclination) x acceleration of gravity (9.8 m/s²). Threshold for cutaneous heat loss: was defined as T_{core} mean registered at the time when T_{skin} significantly increased from the lowest measure registered during exercise (8). Heat loss sensitivity: was calculated from the regression slope of T_{core} and T_{skin} during first four minutes after the threshold was achieved (8). Heat loss index: was calculated as $HLI = (T_{skin} - T_{amb}) / (T_{core} - T_{amb})$, where T_{skin} is tail skin temperature, T_{amb} is ambient temperature, and T_{core} is core temperature. HLI varies from 0 (maximum vasoconstriction) to 1 (maximum vasodilation) (14)

Statistics:

The Shapiro-Wilk test was used to analyze the normality of the data. Body mass, blood pressure, workload, thermoregulatory and calculated variables were tested using two-way ANOVA followed by Bonferroni post hoc. Data were presented as media \pm SD. An alpha of 5% was used.

3- Results:

Table 1 shown body mass and blood pressure results. *Body mass.* Were found both strain and age effects. WIS showed higher body mass (g) compared to WKY and SHR in all ages ($p < 0,05$). WIS strain present an increased in body mass with 72 weeks compared to 16 weeks ($p < 0,05$), while WKY and SHR present an body mass increased with 48 and 72 weeks compared to 16 weeks ($p < 0,05$).

Blood pressure. A both strain and age effects were observed. SHR presented higher SBP (mmHg) compared to WIS and WKY in all ages ($p < 0,05$). With 48 and 72 weeks, WKY shown higher SBP compared to WIS ($p < 0,05$). SHR shown increased SBP with 48 and 72 compared to 16 weeks ($p < 0,05$). For DBP (mmHg) results, SHR shown higher DBP (mmHg) compared to WIS with 16, 48 and 72 weeks ($p < 0,05$) and compared to WKY with 48 and 72 weeks ($p < 0,05$). WKY presented higher

DBP compared to WIS with 48 weeks ($p < 0.05$). SHR present increased DBP with 72 compared to 16 weeks ($p < 0,05$). For MAP (mmHg) results, SHR shown higher MAP compared to WIS with 16, 48 and 72 weeks ($p < 0,05$) and compared to WKY with 48 and 72 weeks ($p < 0.05$). WKY presented higher MAP compared to WIS with 48 weeks ($p < 0.05$). SHR present increased of MAP with 48 and 72 compared to 16 weeks ($p < 0,05$).

Table 1. Body mass and blood pressure measurements.

	WIS16 (n=8)	WKY16 (n=8)	SHR16 (n=8)	WIS48 (n=8)	WKY48(n=8)	SHR48 (n=8)	WIS72 (n=8)	WKY72 (n=8)	SHR72 (n=7)
Body mass (g)	420.00 ± 30.75	355.12 ± 34.79 ^ψ	282.85 ± 13.6 ^{\$&}	479.85 ± 40.72	385.00 ± 42.01 ^{*ψ}	397.37 ± 24.33 ^{*\$}	527.57 ± 31.02 [#]	446.71 ± 27.52 ^{#ψ}	436.42 ± 27.09 ^{\$#}
SBP (mmHg)	123.29 ± 4.89	134.71 ± 6.82	156.57 ± 11.38 ^{\$&}	116.14 ± 8.15	142.85 ± 14.50 ^ψ	195.14 ± 13.29 ^{*\$&}	120.42 ± 5.22	143.00 ± 9.09 ^ψ	193.57 ± 18.12 ^{#\$&}
DBP (mmHg)	87.71 ± 14.46	97.71 ± 14.02	109.42 ± 23.07 ^{\$}	72.14 ± 10.44	94.85 ± 13.81 ^ψ	128.00 ± 22.83 ^{\$&}	78.85 ± 14.72	94.14 ± 20.15	138.28 ± 27.35 ^{#\$&}
MAP (mmHg)	99.00 ± 10.11	109.85 ± 11.24	121.00 ± 19.25 ^{\$}	85.71 ± 10.57	116.28 ± 10.11 ^ψ	146.42 ± 21.73 ^{*\$&}	96.00 ± 7.16	109.42 ± 22.38	162.00 ± 23.34 ^{#\$&}

SBP- systolic blood pressure; DBP- diastolic blood pressure; MAP- mean arterial pressure. Data are presented as mean ± SD. \$- SHR vs. WIS; &- SHR vs. WKY; ψ- WKY vs. WIS; *- 48 vs. 16; #- 72 vs. 16 (p<0.05).

Figure 1 shows the results of the workload (J) during MTF (A) and CT (B) protocols. Both strain and aging effects were observed. During MTF test (panel A), SHR performed lower workload compared to WIS and WKY with 16 weeks ($p < 0.05$). With 72 weeks, SHR and WKY presented lower workload compared to WIS ($p < 0.05$). WKY presented decreased of workload with 48 and 72 compared to 16 weeks ($p < 0.05$), while SHR presented reduced workload with 72 compared to 48 weeks ($p < 0.05$). Panel B present the workload during CT protocol. WKY and SHR presented lower workload compared to WIS with 16 and 72 weeks ($p < 0.05$).

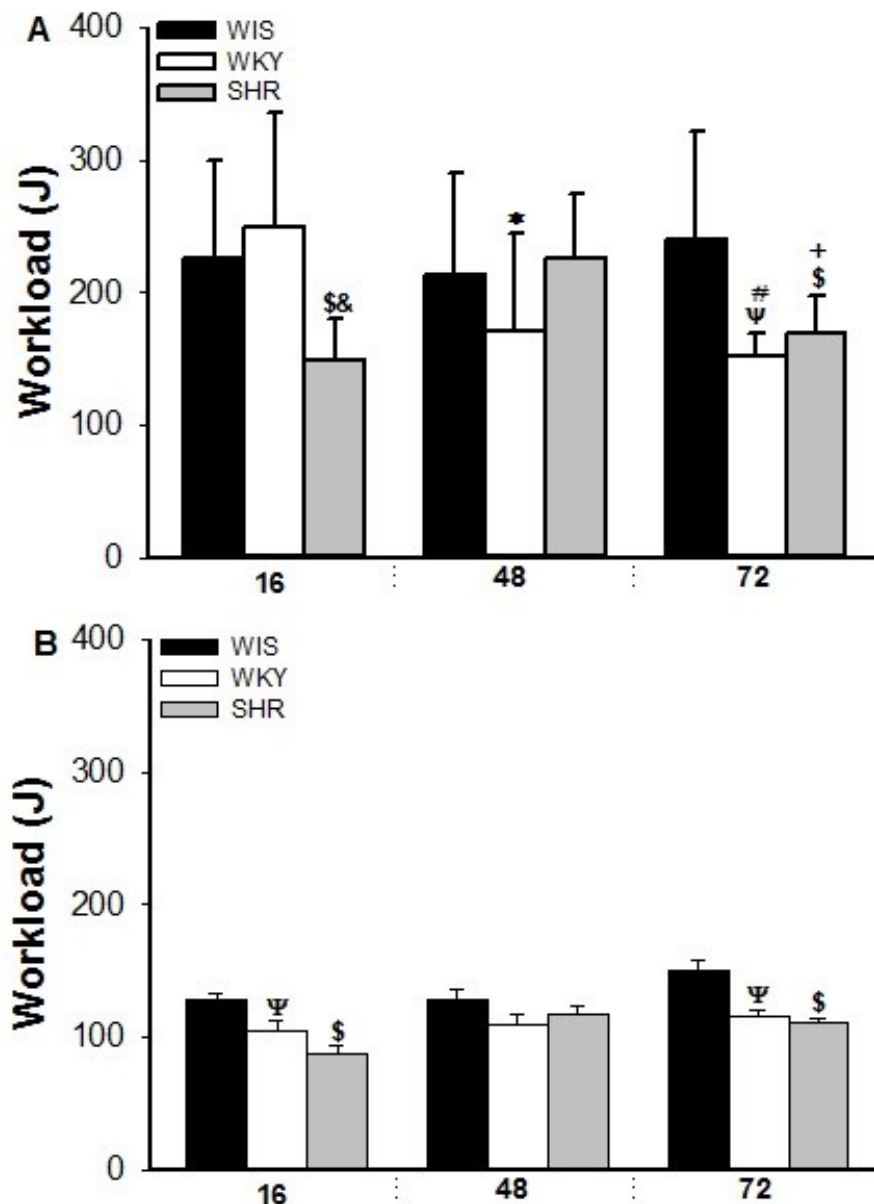

Figure 1. Long term behavior of workload in MTF (A) and CT (B) of WIS16 (n=8), WKY16 (n=8), SHR16 (n=8), WIS48 (n=8), WKY48 (n=8), SHR48 (n=8), WIS72 (n=8), WKY72 (n=8) and SHR72 (n=7). Data are presented as mean \pm SD. Statistical significance ($p < 0,05$) are showed as follows: \$- SHR vs. WIS; &- SHR vs. WKY; Ψ - WIS vs. WKY; *- 48 vs. 16; #- 72 vs. 16; +- 72 vs. 48.

Figure 2 shows the T_{core} and T_{skin} results during MTF (Panels A and B) and CT (panels C and D) protocols. Both strain and aging effects were observed. In MTF, SHR with 48 weeks presented higher T_{core} compared to WIS and WKY (Panel A; $p < 0.05$). For T_{skin} (Panel B), SHR shown lower values compared to WIS and WKY with 16 and 48 weeks ($p < 0.05$). With 72 weeks, WIS presented lower T_{skin} compared to WKY and SHR ($p < 0.05$). WIS and WKY strains presented T_{skin} reduced with 72 compared to 16 and 48 weeks ($p < 0.05$). In CT protocol, SHR with 48 weeks presented higher T_{core} compared to WKY (Panel A; $p < 0.05$). For T_{skin} (Panel B), SHR shown lower values compared to WIS and WKY with 16 and 48 weeks ($p < 0.05$). With 72 weeks, WIS presented lower T_{skin} compared to WKY and SHR ($p < 0.05$). WIS and WKY strains presented T_{skin} reduced with 72 compared to 16 and 48 weeks ($p < 0.05$).

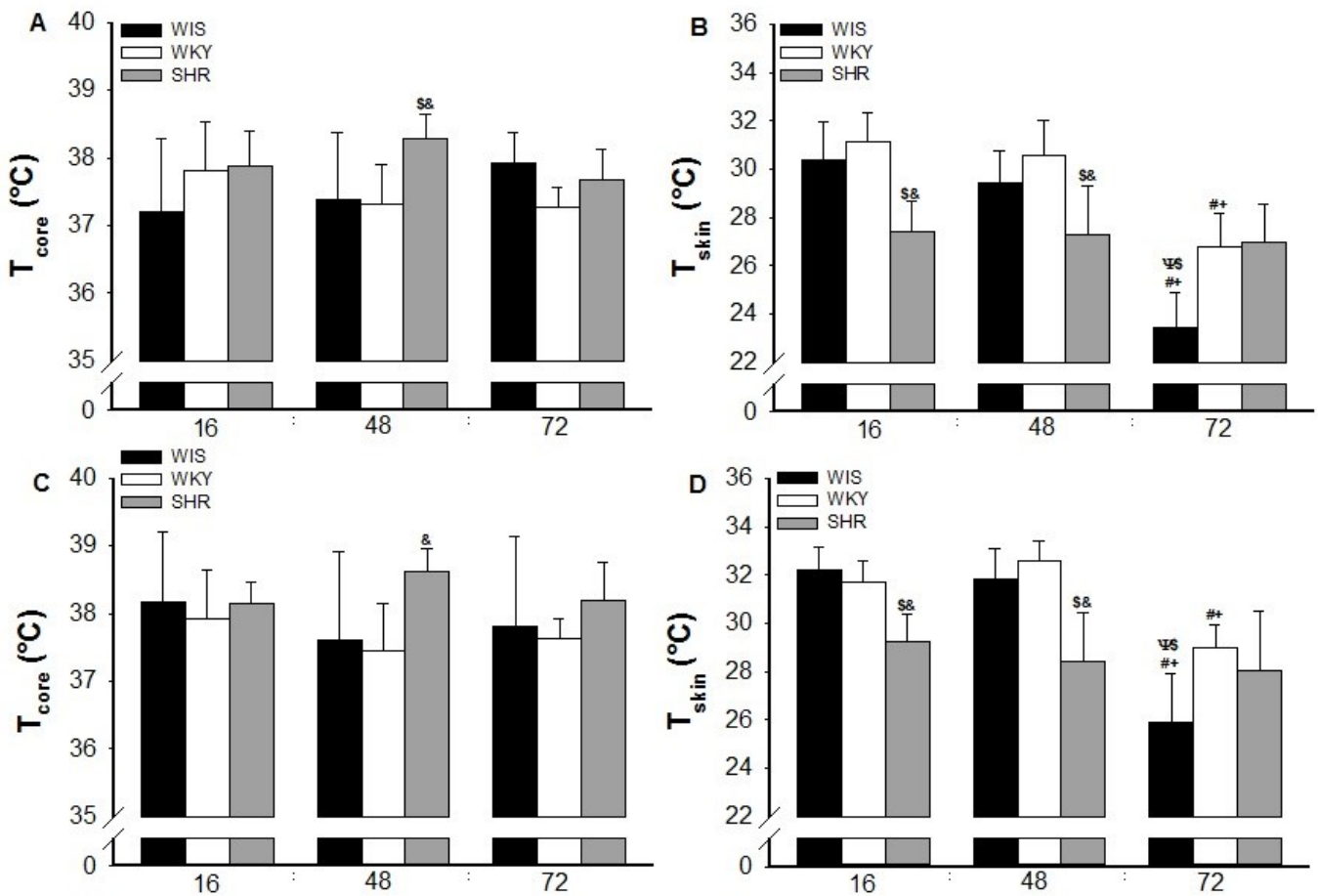

Figure 2. Long term behavior of T_{core} and T_{skin} in MTF (A and B) and CT (C and D) of WIS16 (n=8), WKY16 (n=8), SHR16 (n=8), WIS48 (n=8), WKY48 (n=8), SHR48 (n=8), WIS72 (n=8), WKY72(n=8) and SHR72 (n=7). Data are presented as mean \pm SD. Statistical significance ($p < 0.05$) are showed as follows: \$- SHR vs. WIS; &- SHR vs. WKY; Ψ- WIS vs. WKY; *- 48 vs. 16; #- 72 vs. 16; +- 72 vs. 48.

Figure 3 point the results of HLI in MTF. The strain effects were presented in panels A, B and C, and aging effects were shown in panels D, E and F. Both strain and age effects were found. SHR

presented lower HLI compared to WIS (min: 09-15; $p<0,05$) and WKY (min: 08-15; $p<0,05$) with 16 weeks. SHR presented lower HLI compared to WIS (min: 11-15; $p<0,05$) and WKY (min: 06-15; $p<0,05$) with 48 weeks. No differences between strains were observed with 72 weeks. The aging analysis show that WIS with 72 weeks presented decreased in HLI compared to 16 and 48 weeks (min: 0-15; $p<0,05$). WKY with 72 weeks presented decreased in HLI compared to WKY with 16 (min: 0-03; 08-12; $p<0,05$) and 48 weeks (min: 05-08; 10-14; $p<0,05$). No aging effects were observed to SHR.

Figure 4 presented the results of HLI in CT. The strain effects were presented in panels A, B and C, and aging effects were shown in panels D, E and F. Both strain and age effects were found. SHR presented reduced HLI compared to WIS (min: 8-20; $p<0.05$) and WKY (min: 9-19; $p<0.05$) with 16 weeks (panel A). With 48 weeks (panel B), SHR presented reduced HLI compared to WIS (min: 7 and 8; 10-24; $p<0.05$) and WKY (min: 5-25; $p<0.05$). With 72 weeks (panel C), WIS presented lower HLI compared to SHR (min: 0-3 and 5; $p<0.05$), and compared to WKY (min: 0-2, 5-6 and 10-19; $p<0.05$). When evaluated aging effect for WIS group (panel D), we observe that WIS with 72 weeks shown HLI decreased compared to 16 (min: 0-30; $p<0.05$) and 48 weeks (min: 0 -2, 7-30; $p<0.05$). For WKY (panel F), the rats with 48 weeks shown decreased of HLI compared to 16 weeks (min: 7-9; $p<0.05$). Also, WKY with 72 weeks shown decreased of HLI compared to 16 (min: 9-11; $p<0,05$) and 48 weeks (min: 4-30; $p<0.05$). No differences were found to SHR strain.

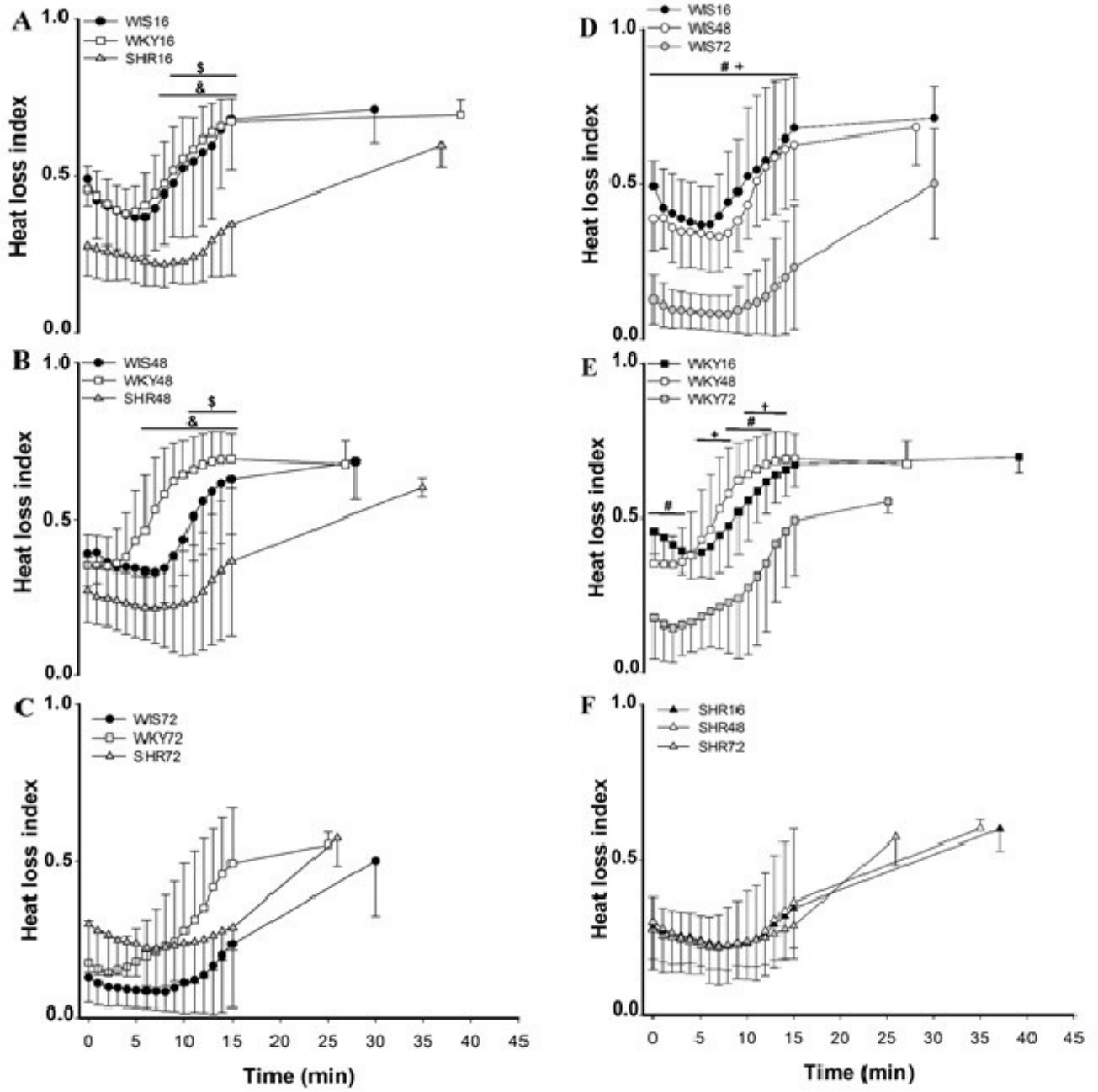

Figure 3. Long term behavior of HLI in MTF (A, B and C- strain effect; C, D and F- aging effect) of WIS16 (n=8), WKY16 (n=8), SHR16 (n=8), WIS48 (n=8), WKY48 (n=8), SHR48 (n=8), WIS72 (n=8), WKY72(n=8) and SHR72 (n=7). Data are presented as mean \pm SD. Statistical significance ($p < 0,05$) are showed as follows: \$- SHR vs. WIS; &- SHR vs. WKY; #- 72 vs. 16; +- 72 vs. 48.

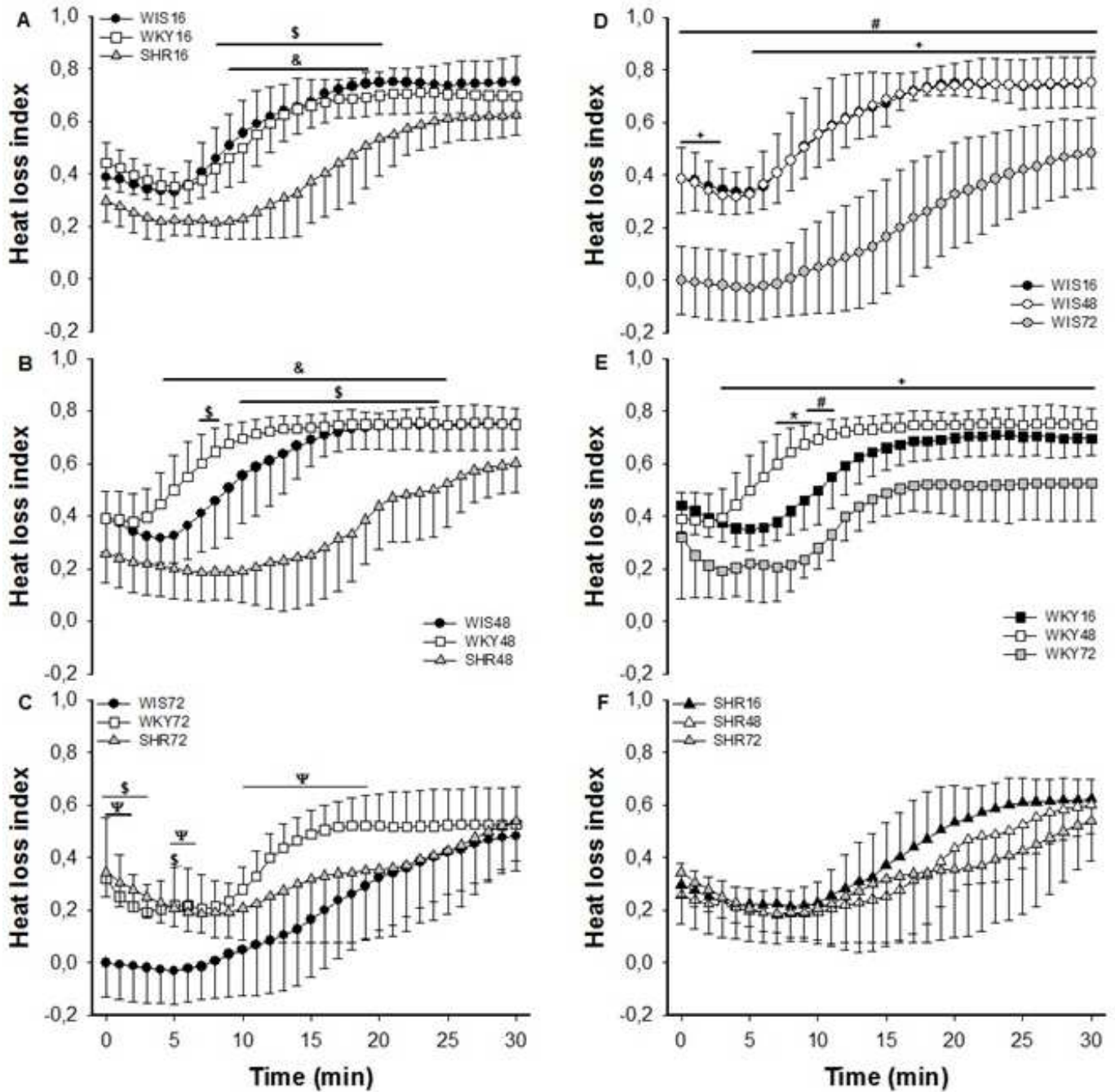

Figure 4. Long term behavior of HLI in CT (A, B and C- strain effect; C, D and F- aging effect) of WIS16 (n=8), WKY16 (n=8), SHR16 (n=8), WIS48 (n=8), WKY48 (n=8), SHR48 (n=8), WIS72 (n=8), WKY72(n=8) and SHR72 (n=7). Data are presented as mean \pm SD. Statistical significance ($p < 0.05$) are showed as follows: \$- SHR vs. WIS; &- SHR vs. WKY; Ψ- WIS vs. WKY; *- 48 vs. 16; #- 72 vs. 16; +- 72 vs. 48.

4- Discussion:

The present study evaluated the long-term behavior (16, 48 and 72 weeks) of thermoregulation responses during MTF and CT of SHR and its normotensive controls. The animals were studied in these ages because are important moments of SHR disease development, in which enters the compensated phase of hypertension with 16 weeks and start the cardiac insufficiency phase around 72 weeks (25). Our main finding was that 16 weeks seems to be a critical age for SHR development, since the analyzed variables already presented disorders at this moment compared to normotensive animals. Additionally, SHR with 16 and 48 weeks presented reduced heat loss capacity, indicated by lower T_{skin} and reduced HLI. Finally, the both normotensive strains presented aging thermoregulatory disorders with 72 weeks, indicated by decreased heat loss capacity, and this was more evident for WIS strain.

The animals were submitted to two different models of aerobic exercise. The first comprised an MTF, which imposes a periodic increase in overload (1m/min in each 3min), inducing constant adjustments of the physiological variables until fatigue. The second was a CT, in which the animals ran for 30 minutes at a moderate intensity (60% of the maximal velocity). Campos *et al.* (2020) show that workload is the most reliable index to evaluated the performance in aerobic exercise between rats with body mass differences (17). We observe that WIS are heavier than WKY and SHR in all ages. Even heavier, they present better performance compared to SHR with 16 weeks and compared to SHR and WKY with 72 weeks in MTF. When analyzed the CT, the WIS exhibited better workload with 16 and 72 weeks compared both WKY and SHR. The WKY and SHR workload are very close. As previously pointed out, the SHR strain suffer several hypertension damages, what induced the reduced exercise capacity (7, 8, 15, 16, 18, 19). Although controversial, there are studies that point to WKY as a strain that can develop hypertension, as well as presenting the pathophysiological disorders imposed by it, such as concentric pathological hypertrophy of the left ventricle and sympathetic hyperactivity (26, 27). In this study, we observed that WKY strain has higher SBP than WIS, in addition to close to the hypertension borderline (150mmHg).

Despite the differences between the exercise protocols used (MTF and CT), there was a very similar response for T_{core} , T_{skin} and HLI for both exercise models in all studied strains. The only difference observed for T_{core} occurred in Hypertensive animals with 48 weeks, that presented higher T_{core} in both protocols compared to WKY and compared to WIS just in MTF. However, our main result is the heat loss capacity, as the SHR showed lower T_{skin} and HLI with 16 and 48 weeks. The caudal artery vasodilation is determinant for heat dissipation in rats, since this is the only hair-free region, besides its great relation between area and volume, favoring the heat exchange with the environment (28). The HLI results point that SHR have reduced vasodilation during exercise. In agreement with our results, evidence indicates that SHR has resistance to blood flow for the tail, which occurs due to functional and morphological changes in the small peripheral arteries, resulting in limited vasodilation, thus

contributing to reduction in heat dissipation capacity (13, 29). Aligned of this, higher DBP is indicative of peripheral vascular resistance (30), and can explain the lower T_{skin} observed in SHR with 16 and 48 weeks.

Our group has demonstrated in recent years that hypertensive animals show impairments in thermoregulatory control during physical exercise (8, 9, 15, 16). This findings point mainly to a greater heat accumulation, indicated by higher central temperatures reached, which consequently contributes to the performance decrease of hypertensive animals (9, 15-17). In this study, we found no extensive differences in T_{core} . However, our data clearly point to a disturbance in the mechanism of heat dissipation in hypertensive animals, which is indicated by the lower T_{skin} and lower HLI observed.

Both normotensive strains presented reduced HLI and T_{skin} with aging, which are more evident to WIS strain. Even in senescent aging there may be a decline in cardiovascular functions, with events such as greater sympathetic activity (31, 32). As well, the blood vessels become hypertrophied and lose elasticity, becoming stiffer, leading to function loss and causing problems such as peripheral vascular resistance and consequently reduced HLI and T_{skin} (31). The reduced HLI and T_{skin} induced by aging did not occur in hypertensive animals, indicating that this group has already presented deleterious changes in the structures that heat dissipation via skin since the first measurement performed, at 16 weeks.

Experimental paradigm:

There is a debate in the literature about the experimental strain to be used as controls for the SHR (26, 27, 33). Both strains are established and widely used, there are even studies that indicating their simultaneous use, aiming to avoid possible loss of disease effects when interpreting results (33-35). This work showed that normotensive animals have particularities. WIS are heavier animals and seems suffer more the aging impact of heat dissipation variables, while WKY have blood pressure values close to borderline hypertension. However, in general, these distinctions of origin did not generate significant differences in thermoregulatory responses, and they showed a very similar behavior in the measurements obtained. Both showed a reduction in T_{skin} and HLI due to aging, confirming that both can be used as controls for the hypertensive animal.

5- Conclusions:

The SHR presented less effective heat dissipation response during exercise. Furthermore, they show an equal response at all ages studied, indicating that at 16 weeks hypertension has already caused serious damage to the thermoregulatory control. Finally, the both normotensive controls can be used as SHR control. However, the WIS strain seems to be more affected to aging process than WKY.

6- References

1. Whelton PK. Hypertension curriculum review: epidemiology and the prevention of hypertension. *J Clin Hypertens (Greenwich)*. 2004 Nov;6(11):636-42.
2. Pescatello LS, Franklin BA, Fagard R, Farquhar WB, Kelley GA, Ray CA. American College of Sports Medicine position stand. Exercise and hypertension. *Med Sci Sports Exerc*. 2004 Mar;36(3):533-53.
3. Korhonen J, Koskinen P. Acute myocardial infarction. A study of the sex distribution, immediate mortality, age distribution, incidence of hypertension and diabetes, and the effect of the seasons in a series of 376 cases. *Ann Med Intern Fenn*. 1960;49:247-54.
4. Rostand SG, Brown G, Kirk KA, Rutsky EA, Dustan HP. Renal insufficiency in treated essential hypertension. *N Engl J Med*. 1989 Mar 16;320(11):684-8.
5. Doggrell SA, Brown L. Rat models of hypertension, cardiac hypertrophy and failure. *Cardiovascular Research*. 1998 Jul;39(1):89-105.
6. Okamoto K, Aoki K. Development of a strain of spontaneously hypertensive rats. *Jpn Circ J*. 1963 Mar;27:282-93.
7. O'Donnell A, Volicer L. Thermoregulation in spontaneously hypertensive rats: effects of antihypertensive treatments. *Clin Exp Hypertens*. 1981;3(3):555-67.
8. Drummond LR, Kunstetter AC, Vaz FF, Campos HO, Andrade AG, Coimbra CC, et al. Brain Temperature in Spontaneously Hypertensive Rats during Physical Exercise in Temperate and Warm Environments. *Plos One*. 2016;11(5):e0155919.
9. Campos HO, Leite LHR, Drummond LR, Cunha DNQ, Coimbra CC, Natali AJ, et al. Temperature Control of Hypertensive Rats during Moderate Exercise in Warm Environment. *J Sport Sci Med*. 2014 Sep;13(3):695-701.
10. Gonzalez-Alonso J. Human thermoregulation and the cardiovascular system. *Experimental Physiology*. 2012 Mar;97(3):340-6.
11. Tansey EA, Johnson CD. Recent advances in thermoregulation. *Adv Physiol Educ*. 2015 Sep;39(3):139-48.
12. Primola-Gomes TN, Pires W, Rodrigues LO, Coimbra CC, Marubayashi U, Lima NR. Activation of the central cholinergic pathway increases post-exercise tail heat loss in rats. *Neurosci Lett*. 2007 Feb 8;413(1):1-5.
13. O'Leary DS, Johnson JM, Taylor WF. Mode of neural control mediating rat tail vasodilation during heating. *J Appl Physiol (1985)*. 1985 Nov;59(5):1533-8.
14. Székely M. Skin temperature – skin blood flow. Assessment of thermoregulatory changes. *Acta Physiologica Hungarica*. 1986;68.
15. Drummond LR, Kunstetter AC, Campos HO, Vaz FF, Drummond FR, Andrade AGP, et al. Spontaneously hypertensive rats have greater impairments in regulating abdominal temperature than brain cortex temperature following physical exercise. *Journal of Thermal Biology*. 2019;83:30-6.
16. Gomes L, Drummond LR, Campos HO, Rezende LMT, Carneiro-Junior MA, Oliveira A, et al. Thermoregulation in Hypertensive Rats during Exercise: Effects of Physical Training. *Arq Bras Cardiol*. 2019 Mar 14.
17. Campos HO, Drummond LR, Rodrigues QT, Lima PM, Primola-Gomes TN, Coimbra CC. Exercise capacity in different stages of hypertension in spontaneously hypertensive rats. *J Sports Med Phys Fitness*. 2020 May;60(5):800-5.
18. Nagatomo F, Gu N, Fujino H, Takeda I, Tsuda K, Ishihara A. Skeletal muscle characteristics of rats with obesity, diabetes, hypertension, and hyperlipidemia. *J Atheroscler Thromb*. 2009 Oct;16(5):576-85.
19. Damatto RL, Martinez PF, Lima AR, Cezar MD, Campos DH, Oliveira Junior SA, et al. Heart failure-induced skeletal myopathy in spontaneously hypertensive rats. *Int J Cardiol*. 2013 Aug 10;167(3):698-703.

20. Neves SMP, Ong FMP, Rodrigues LD, Santos RA, Fontes RS, Santana RO. Manual de Cuidados e Procedimentos com Animais de Laboratório do Biotério de Produção e Experimentação da FCF-IQ/USP. (FCF-IQ/USP) IdQ, editor. São Paulo 2013.
21. Balthazar CH, Leite LH, Rodrigues AG, Coimbra CC. Performance-enhancing and thermoregulatory effects of intracerebroventricular dopamine in running rats. *Pharmacol Biochem Behav.* 2009 Oct;93(4):465-9.
22. Soares DD, Lima NR, Coimbra CC, Marubayashi U. Intracerebroventricular tryptophan increases heating and heat storage rate in exercising rats. *Pharmacol Biochem Behav.* 2004 Jun;78(2):255-61.
23. Young AA, Dawson NJ. Evidence for on-off control of heat dissipation from the tail of the rat. *Can J Physiol Pharmacol.* 1982 Mar;60(3):392-8.
24. Brooks GA, White TP. Determination of metabolic and heart rate responses of rats to treadmill exercise. *J Appl Physiol Respir Environ Exerc Physiol.* 1978 Dec;45(6):1009-15.
25. Bing OH, Brooks WW, Robinson KG, Slawsky MT, Hayes JA, Litwin SE, et al. The spontaneously hypertensive rat as a model of the transition from compensated left ventricular hypertrophy to failure. *J Mol Cell Cardiol.* 1995 Jan;27(1):383-96.
26. Aiello EA, Villa-Abrille MC, Escudero EM, Portiansky EL, Perez NG, de Hurtado MC, et al. Myocardial hypertrophy of normotensive Wistar-Kyoto rats. *Am J Physiol Heart Circ Physiol.* 2004 Apr;286(4):H1229-35.
27. Collins HL, Loka AM, DiCarlo SE. Daily exercise-induced cardioprotection is associated with changes in calcium regulatory proteins in hypertensive rats. *American Journal of Physiology-Heart and Circulatory Physiology.* 2005;288:H532-H40.
28. Rand RP, Burton AC, Ing T. The Tail of the Rat, in *Temperature Regulation and Acclimatization.* *Can J Physiol Pharmacol.* 1965 Mar;43:257-67.
29. Folkow B, Hallback M, Lundgren Y, Weiss L. Structurally based increase of flow resistance in spontaneously hypertensive rats. *Acta Physiol Scand.* 1970 Jul;79(3):373-8.
30. Smulyan H, Safar ME. The diastolic blood pressure in systolic hypertension. *Ann Intern Med.* 2000 Feb 1;132(3):233-7.
31. Ferrari AU. Modifications of the cardiovascular system with aging. *Am J Geriatr Cardiol.* 2002 Jan-Feb;11(1):30-3.
32. Wadstrom BN, Fatehali AH, Engstrom G. A vascular aging index as independent predictor of cardiovascular events and total mortality in an elderly urban population. *Angiology.* 2019;24(33):1-9.
33. Felten SY, Weyhenmeyer JA, Felten DL. Norepinephrine and serotonin in central autonomic nuclei in the spontaneously hypertensive rat and two normotensive control rats. *Brain Res Bull.* 1984 Sep;13(3):437-41.
34. Hard E, Carlsson SG, Jern S, Larsson K, Lindh AS, Svensson L. Behavioral reactivity in spontaneously hypertensive rats. *Physiol Behav.* 1985 Oct;35(4):487-92.
35. Sagvolden T, Pettersen MB, Larsen MC. Spontaneously hypertensive rats (SHR) as a putative animal model of childhood hyperkinesis: SHR behavior compared to four other rat strains. *Physiol Behav.* 1993 Dec;54(6):1047-55.