

ÉRICA FELIPE MAURÍCIO

**THE EFFECT OF SUGAR ADDITION ON THE PHYSICAL PROPERTIES OF MILK
CONCENTRATES AND THE FOULING OF EQUIPMENT – INVESTIGATIONS AT
LAB AND PILOT-SCALES**

Thesis presented to the Universidade Federal de Viçosa as part of the requirements for the Graduate Program in Food Science and Technology to obtain the title of *Doctor Scientiae*.

Advisor: Ítalo Tuler Perrone

Co-advisors: Antônio Fernandes de Carvalho
Rodrigo Stephani

**VIÇOSA - MINAS GERAIS
2021**

**Ficha catalográfica elaborada pela Biblioteca Central da Universidade
Federal de Viçosa - Campus Viçosa**

T

M455e
2021

Maurício, Érica Felipe, 1990-
The effect of sugar addition on the physical properties of
milk concentrates and the fouling of equipment: investigations at
lab and pilot-scales / Érica Felipe Maurício. – Viçosa, MG, 2021.
1 tese eletrônica (65 f.): il. (algumas color.).

Orientador: Ítalo Tuler Perrone.

Tese (doutorado) - Universidade Federal de Viçosa,
Departamento de Tecnologia de Alimentos, 2021.

Inclui bibliografia.

DOI: <https://doi.org/10.47328/ufvbbt.2021.269>

Modo de acesso: World Wide Web.

1. Leite concentrado. 2. Doce de leite. 3. Leite condensado.
I. Perrone, Ítalo Tuler. II. Universidade Federal de Viçosa.
Departamento de Tecnologia de Alimentos. Programa de
Pós-Graduação em Ciência e Tecnologia de Alimentos.
III. Título.

CDD 22. ed. 637.142

ÉRICA FELIPE MAURÍCIO

THE EFFECT OF SUGAR ADDITION ON THE PHYSICAL PROPERTIES OF MILK
CONCENTRATES AND THE FOULING OF EQUIPMENT – INVESTIGATIONS AT
LAB AND PILOT-SCALES

Thesis presented to the Universidade Federal
de Viçosa as part of the requirements for the
Graduate Program in Food Science and
Technology to obtain the title of *Doctor
Scientiae*.

APPROVED: October 1st, 2021.

Assent:

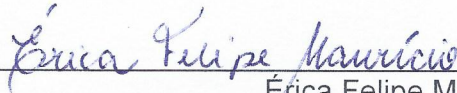

Érica Felipe Maurício
Author



Italo Tuler Perrone
Advisor

I dedicate to the people more important of
my life, my parents.

ACKNOWLEDGMENTS

To Federal University of Viçosa (Department of Food Technology) and Federal University of Juiz de Fora (Department of Chemistry) for the opportunity of learning, material and structure support.

To INOVALEITE Group under Coordination of Professor Antônio Fernandes de Carvalho and NEEM/QUIMTEC (Spectroscopy and Molecular Structure Nucleus/ Laboratory of Chemistry and Technology) under coordination of Professors Luiz Fernando Cappa de Oliveira, Rodrigo Stephani and Ítalo Tuler Perrone for the opportunity to grow both professionally and personally.

To SMCF (Séchage, Matrices Concentrées et Fonctionnalités) team of STLO-INRAe for all the reception and support throughout the analysis and productions, specially Gaëlle Tanguy who ended up becoming a friend.

To my advisor, professor Ítalo Tuler Perrone and my co-advisors, professors Antônio Fernandes de Carvalho and Rodrigo Stephani for all their trust, availability, care and for transmitting their knowledge during all these years.

To my professional friends from Inovaleite, Viçosa and Chr Hansen, especially Carolina Rodrigues, Júlia Francisquini, Fernanda Lopes, Camila Rocha, Simone Medeiros, Luan Marciano e Bruna Guimaro for all the exchange of knowledge, works developed in partnership and for all the laughs.

To my parents, Elenice and Ferdinando, and my aunts, Alice and Elenilda, whom have always encouraged me to take new steps in my professional career.

To my boyfriend Leonardo, who had a lot of patience with me in this final phase of the PhD and also gave me a lot of support.

To everyone who has been rooting for me and contributed to this achievement, my thanks!

Finally, I would like to thank the support provided by the funding agencies: CAPES, CNPQ, FAPEMIG.

This study was financed by the Coordenação de Aperfeiçoamento de Pessoal de Nível Superior – Brasil (CAPES) – Finance Code 001.

ABSTRACT

MAURÍCIO, Érica Felipe, D.Sc., Universidade Federal de Viçosa, October, 2021. **The effect of sugar addition on the physical properties of milk concentrates and the fouling of equipment – Investigations at lab and pilot-scales.** Advisor: Ítalo Tuler Perrone. Co-advisors: Antônio Fernandes de Carvalho and Rodrigo Stephani.

Dairy products are highly consumed due to their high nutritional value and pleasant taste. One of the processes that milk can undergo is concentration, which provides some benefits, such as an increase in shelf life and a reduction in transport costs. In addition, the addition of sugar to milk is intended to create a new product, for example, dulce de leche and condensed milk, also increases the product's added value. The addition of sugar to milk generates significant processing changes for the product when compared to pure milk. These differences range from physicochemical properties to the formation of deposits in the heat exchanger. These changes must be considered in the development of new products, especially with the growing consumer demand for products with lower sugar content. According to recent studies, it was possible to observe through methods such as energy dispersive spectroscopy, Raman spectroscopy and scanning electronic microscopy that the reduction of sugar in dulce de leche leads to significant changes in the quantity and composition of deposits formed over the dulce de leche manufacture period using the atmospheric pressure concentration process. This factor directly affects the aspect of industrial cleaning, requiring more attention in terms of time and specific products. Vacuum concentration is usually studied in large evaporators that consume large volumes of milk, being an impediment to research and development tests. Therefore, in this study, two different scales were used – pilot and laboratory, for the manufacture of two dairy products (without addition of sucrose and with the addition of 20% ($m \cdot m^{-1}$) of sucrose). And the formed products were analyzed in relation to the parameters of viscosity, density and surface tension. By observing these three parameters, it was possible to verify that there was no significant difference between the manufacturing scales. Therefore, the products manufactured in them are similar and possible to be studied on a smaller scale. This favors not only the cost reduction aspect for the industry, but also the reduction of environmental impacts, since it reduces water consumption and disposal of organic matter, for example.

Keywords: Dulce de leche. Concentrated milk. Sweetened condensed milk.

RESUMO

MAURÍCIO, Érica Felipe, D.Sc., Universidade Federal de Viçosa, outubro de 2021. **O efeito da adição de açúcar nas propriedades físicas dos concentrados de leite e na incrustação do equipamento - Investigações em escalas laboratorial e piloto.** Orientador: Ítalo Tuler Perrone. Coorientadores: Antônio Fernandes de Carvalho e Rodrigo Stephani.

Os produtos lácteos são muito consumidos devido ao seu alto valor nutritivo e sabor agradável. Um dos processos pelos quais o leite pode passar é a concentração, que traz alguns benefícios, tais como o aumento do tempo de conservação e a redução dos custos de transporte. Além disso, a adição de açúcar ao leite tem como propósito a formação de um novo produto, como exemplo temos o doce de leite e o leite condensado, que faz com que aumente o seu valor agregado. A adição de açúcar ao leite gera mudanças significativas no processamento do produto quando comparado ao leite puro. Essas diferenças variam desde propriedades físico-químicas à formação de depósitos no trocador de calor. Essas mudanças devem ser levadas em consideração no desenvolvimento de novos produtos, principalmente com a crescente demanda dos consumidores por produtos com menor teor de açúcar. De acordo com os recentes estudos foi possível observar por meio de métodos como espectroscopia de energia dispersiva, espectroscopia Raman e microscopia eletrônica de varredura que a diminuição de açúcar em doce de leite leva à mudanças significativas da quantidade e da composição dos depósitos formados ao longo da fabricação de doce de leite utilizando o processo de concentração a pressão atmosférica. Este fator implica diretamente no aspecto da limpeza industrial, exigindo mais atenção em tempo e produtos específicos. A concentração à vácuo, normalmente, é estudada em grandes evaporadores que consomem grandes volumes de leite, sendo um empecilho para testes de pesquisa e desenvolvido. Portanto, neste estudo foram empregadas duas escalas distintas – piloto e laboratorial, para a fabricação de dois produtos lácteos (sem adição de sacarose e com adição de 20 % ($m \cdot m^{-1}$) de sacarose). E os produtos formados foram analisados em relação aos parâmetros de viscosidade, densidade e tensão superficial. Ao observar esses três parâmetros, foi possível constatar que não houve diferença significativa entre as escalas de fabricação. Portanto, os produtos fabricados nelas são semelhantes e possíveis de seres estudados em escala menor. O que favorece não só o aspecto de diminuição de

custos para a indústria, como também a diminuição de impactos ambientais, uma vez que diminui o consumo de água e descarte de matéria orgânica, por exemplo.

Palavras-chave: Doce de leite. Leite concentrado. Leite condensado.

CONTENTS

1. GENERAL INTRODUCTION.....	10
2. PAPER 1.....	16
2.1. Supplementary file of paper 1.....	27
3. PAPER 2.....	37
4. OTHER PUBLICATIONS DEVELOPED DURING THE DOCTORATE.....	64
5. GENERAL CONCLUSIONS AND PERSPECTIVES	65

1. GENERAL INTRODUCTION

One of the methods used to preserve milk is concentration. This technique consists of partial removal of water from the raw material. Decreasing the product's water activity lengthens product shelf life and thus reduces the growth of microorganisms. In addition, the concentration enables the manufacture of different products, such as dulce de leche and sweetened condensed milk (Carvalho *et al.*, 2013).

Dulce de leche, according to the Brazilian Legislation, Ordinance No. 354, September 4, 1997 (BRASIL, 1997), is the product with or without the addition of other food substances, obtained by concentration and heat action at normal or reduced pressure of milk or reconstituted milk, with or without addition of milk solids and/or cream added with sucrose (partially substituted or not by monosaccharides and/or other disaccharides). In Brazilian industries, atmospheric pressure pans are normally used (Perrone, Stephani e Neves, 2011). This process requires higher temperatures, which favor the browning of the sugar due to the Maillard reaction. This reaction occurs between an amino acid (in milk, for example lysine) and a reducing sugar (in milk, for example lactose) that generates melanoidins responsible for the formation of color, aroma and flavor (Tamime, 2009).

Concentration in pans is done in a batch process, that is, the syrup (milk + sucrose) is already prepared directly in the equipment in an established quantity according to the pan's capacity. The pan has a double wall (Figure 1) through which the steam responsible for heating the product circulates. This heating occurs gradually and under continuous agitation until the desired concentration is reached, at which point it leaves the equipment (Perrone, Stephani e Neves, 2011).

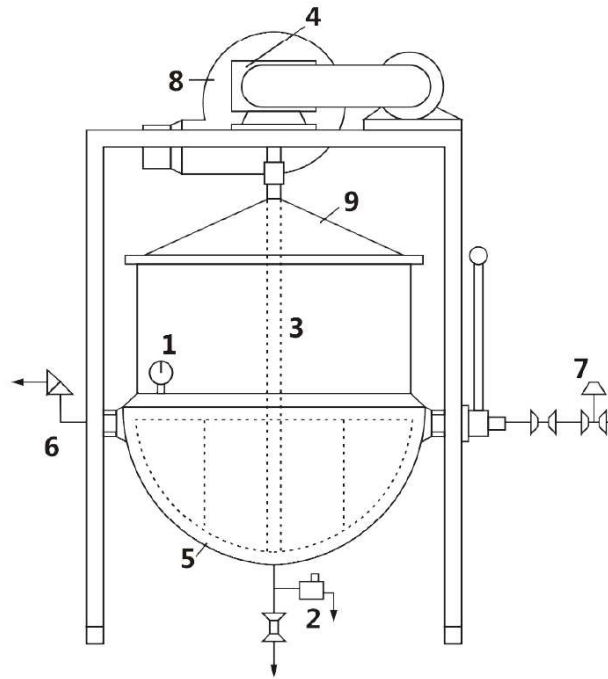

Figure 1 - Pan layout for making dulce de leche (Perrone, Stephani e Neves, 2011). Where 1- manometer, 2- trap, 3- agitator shaft, 4- reduction box, 5- steam double wall, 6- safety valve, 7- pressure reducing valve, 8- exhaust and 9- cover.

Sweetened condensed milk, in accordance with Normative Instruction No. 47, October 26, 2018 (BRASIL, 2018), is the product resulting from the partial dehydration of milk, concentrated milk or reconstituted milk, with the addition of sugar, and may have its fat and protein contents adjusted only to maintain the product's characteristics. For the production of this type of product, a falling film evaporator at reduced pressure is normally used (Renhe, Perrone e Silva, 2011). This modification of the evaporation process in relation to dulce de leche is done mainly to alter the characteristic color of the final product. When using the vacuum evaporation process, the evaporation temperature becomes lower, thus reducing not only the Maillard reaction but also the protein denaturation. This is also the most commonly used process for concentrating pure milk.

The concentration of pure milk is made in order to reduce the volume of milk and reduce packaging, transport and storage costs of the final product (Silveira *et al.*, 2015). But it can also be used as an intermediate step for the drying process (producing powdered milk) (Gourdon e Mura, 2017). Thus, the study of the concentration process is also important to establish the best concentration parameters (Madoumier *et al.*, 2015) and to have the lowest possible processing losses.

The vacuum concentration process in the falling film evaporator (equipment used for the production of sweetened condensed milk and concentrated milk) is composed of 3 main steps: evaporation, separation and condensation (Figure 2). The product to be concentrated is pumped to the top of the concentration tube and spread over a distribution plate (Figure 3). This distribution is intended to ensure the uniform division of the product and the formation of a very thin film. As the product flows by gravity through the heated wall, it evaporates the water and concentrates the dry matter (Tanguy, 2018).

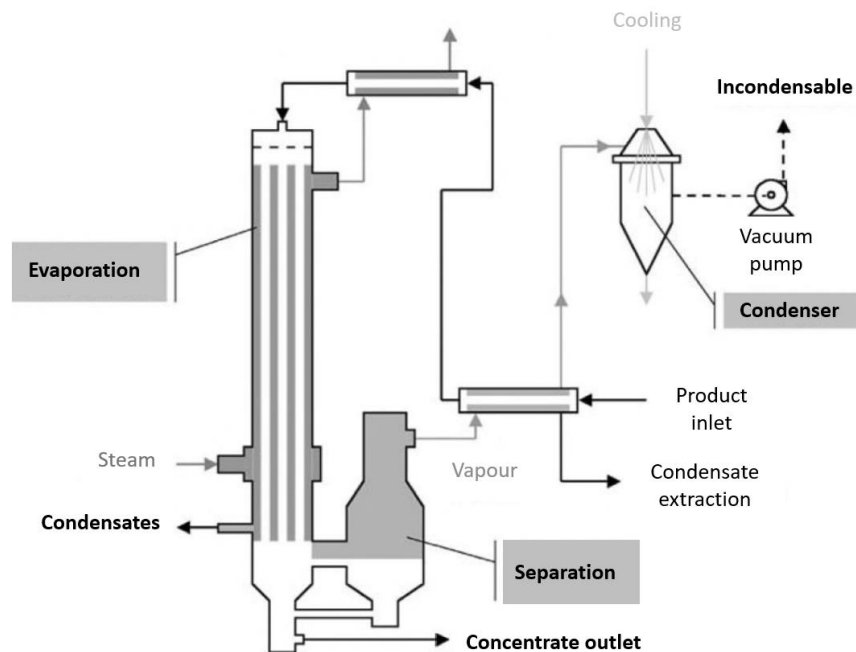

Figure 2 - Layout of a single-effect falling-film evaporator (Jeantet, Brulé e Delaplace, 2011).

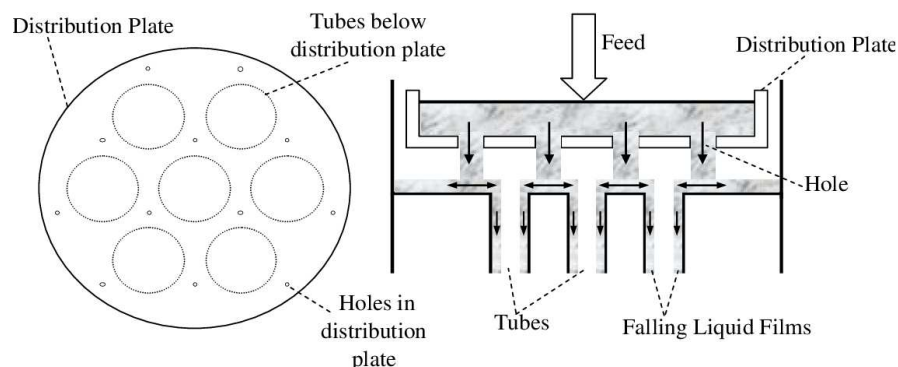

Figure 3 - A distribution plate transfers milk to the tube sheet through holes, where it spreads on the tube sheet and forms a falling film on the inside of the evaporator tubes (Broome, 2005).

In addition, consumers are increasingly looking for healthier products and this leads to the search for foods with a lower sugar content and this demand is also seen in the products covered in this work (dulce de leche and sweetened condensed milk). Therefore, there is a constant search for improvements and innovations that require new formulations. And, regardless of the type of evaporation used, when modifying the formulation of a product, it directly impacts the concentration process. Furthermore, the scientific literature lacks studies that determine the effect of the addition of sucrose on the properties of dulce de leche and sweetened condensed milk, as well as on the formation of deposits in pans and evaporators.

The effect of some modifications are more evident such as: evaporation rate, evaporation time, viscosity increase, film thickness difference and wetting rate (Madoumier *et al.*, 2015). All these factors directly impact the productivity and performance of concentration equipment. Changes to these parameters can generate problems with equipment fouling, which directly impact heat exchange, value efficiency and cleaning frequency (Tanguy *et al.*, 2016).

The addition of sucrose in the production of dulce de leche and sweetened condensed milk constitutes the main processing difference in relation to unsweetened concentrated milk. Sucrose is a non-reducing sugar that is preferably hydrated (Desu e Narishetty, 2013). This causes a layer of water (hydration zone) to form around the proteins (McClements, 2002). This layer protects the proteins and therefore they suffer less from heat treatment (Baier e McClements, 2003). Therefore, for globular proteins this is important, as it will favor their native state, thus decreasing their denaturation (Zhang, Lu e Huang, 2018). By decreasing the denaturation of proteins, there is less exposure of the sulfhydryl groups, which directly impacts the formation of agglomerates and deposition on the heat exchange surface.

In view of the above considerations, the thesis aimed to analyze and meet two current demands of two different papers:

- Increased demand for products with lower sucrose content and the impact this has on the dulce de leche industry. **PAPER 1:** Influence of sucrose reduction on fouling during the production of dulce de leche.

- Need to increase the number of analyses in research and development, while requiring the reduction of environmental impact. **PAPER 2:** Comparison of experimental setups for the production of milk concentrates and subsequent characterization.

** The papers presented below are in the format requested by the different journals in which the works were published.

REFERENCES

- BAIER, S. K.; MCCLEMENTS, D. J. Combined Influence of NaCl and Sucrose on Heat-Induced Gelation of Bovine Serum Albumin. **Journal of Agricultural and Food Chemistry**, v. 51, n. 27, p. 8107–8112, 2003.
- BRASIL. Ministério da Agricultura, Pecuária e Abastecimento. Portaria n. 354, de 04 de setembro de 1997. Regulamento técnico de identidade e qualidade de doce de leite. **Diário Oficial da República Federativa do Brasil**, p. 37–38, 1997.
- BRASIL, M. DA A. P. E A. **Instrução normativa nº47, de 26 de outubro de 2018** - **Normative Instruction No. 47, October 26, 2018** **Diário Oficial da União**, 2018.
- BROOME, S. **Liquid Distribution And Falling Film Wetting In Dairy Evaporators**. [s.l.] University of Canterbury, 2005.
- CARVALHO, A. F. DE; NEVES, B. DOS S.; PERRONE, Í. T.; STEPHANI, R.; VIEIRA, S. D. Á. **Leites concentrados e desidratados**. Juiz de Fora: Templo Gráfica e Editora Ltda., 2013.
- DESU, H. R.; NARISHETTY, S. T. Challenges in Freeze–Thaw Processing of Bulk Protein Solutions. *In*: **Sterile Product Development**. [s.l.] Springer, New York, NY, 2013. p. 167–203.
- GOURDON, M.; MURA, E. Performance evaluation of falling film evaporators in the dairy industry. **Food and Bioproducts Processing**, v. 1, p. 22–31, 2017.
- JEANTET, R.; BRULÉ, G.; DELAPLACE, G. **Génie des procédés appliqué à l'industrie laitière**. 2nd. ed. Rennes: TEC & DOC - Lavoisier, 2011.
- MADOUMIER, M.; AZZARO-PANTEL, C.; TANGUY, G.; GÉSAN-GUIZIOU, G. Modelling the properties of liquid foods for use of process flowsheeting simulators: Application to milk concentration. **Journal of Food Engineering**, v. 164, p. 70–89, 2015.

- MCCLEMENTS, D. J. Modulation of globular protein functionality by weakly interacting cosolvents. **Critical Reviews in Food Science and Nutrition**, v. 42, n. 5, p. 417–471, 2002.
- PERRONE, Í. T.; STEPHANI, R.; NEVES, B. DOS S. **Doce de Leite: Aspectos Tecnológicos**. 1st. ed. Juiz de Fora: Impresso no Brasil, 2011.
- RENHE, I. R. T.; PERRONE, Í. T.; SILVA, P. H. F. DA. **Leite Condensado: Identidade, qualidade e tecnologia**. 1st. ed. Juiz de Fora: Templo Gráfica e Editora Ltda., 2011.
- SILVEIRA, A. C. P.; TANGUY, G.; PERRONE, Í. T.; JEANTET, R.; DUCEPT, F.; CARVALHO, A. F. DE; SCHUCK, P. Flow regime assessment in falling film evaporators using residence time distribution functions. **Journal of Food Engineering**, v. 160, p. 65–76, 2015.
- TAMIME, A. Y. **Milk Processing and Quality Management**. 1st. ed. Ayr: Wiley-Blackwell, 2009.
- TANGUY, G. **Concentration de produits laitiers dans les évaporateurs à flot tombant : facteurs limitants et alternatives technologiques**. [s.l.] Agrocampus Ouest, 2018.
- TANGUY, G.; SIDDIQUE, F.; BEAUCHER, E.; SANTELLANI, A. C.; SCHUCK, P.; GAUCHERON, F. Calcium phosphate precipitation during concentration by vacuum evaporation of milk ultrafiltrate and microfiltrate. **LWT - Food Science and Technology**, v. 69, p. 554–562, 2016.
- ZHANG, B. Y.; LU, J.; HUANG, J. Y. Effect of sugar on the fouling behavior of whey protein. **Food and Bioproducts Processing**, p. 1–8, 2018.

2. PAPER 1

MAURÍCIO, Érica Felipe *et al.* Influence of sucrose reduction on fouling during the production of dulce de leche. *The Journal of dairy research*, 2021. <https://doi.org/10.1017/S0022029921000777>

Journal of Dairy Research

cambridge.org/dar

Research Article

Cite this article: Mauricio EF, Francisquini JDA, de Paula IL, de Cezarino Junior JCC, de Oliveira LFC, Stephani R, De Carvalho AF and Perrone IT. Influence of sucrose reduction on fouling during the production of dulce de leche. *Journal of Dairy Research* <https://doi.org/10.1017/S0022029921000777>

Received: 26 October 2020
Revised: 26 July 2021
Accepted: 3 August 2021

Keywords: Concentration; dulce de leche; reduced sugar and fouling

Author for correspondence: Ítalo T. Perrone,
Email: italotilerperone@gmail.com

Influence of sucrose reduction on fouling during the production of dulce de leche

Érica F. Mauricio¹, Júlia D. A. Francisquini¹, Igor L. de Paula², José C. C. de Cezarino Junior¹, Luiz F. C. de Oliveira², Rodrigo Stephan², Antônio F. De Carvalho¹ and Ítalo T. Perrone³

¹Department of Food Technology, Federal University of Viçosa, Viçosa, Brazil; ²Department of Chemistry and ³Faculty of Pharmacy, Federal University of Juiz De Fora, Juiz De Fora, Brazil

Abstract

In this Research Communication we focus the food industry's broad tendency to decrease sugar content in food products onto dulce de leche (DL) and examine the influence of sucrose reduction on the detrimental deposits formed during the production process. The method used to identify the impact produced directly on the heat exchanger during the production of this product with low sucrose content required varying the quantity of sucrose in the milk. Different percentages of sucrose (20, 15, 10, 5 and 0% w/w) were submitted to the DL concentration process in a process simulator. After concentration, the quantification of the deposits formed in each was carried out and these deposits were characterized according to their composition. Methods such as Kjeldahl, Pregl-Dumas and SEM-EDS were used. Thus, the work highlights the need to change the product manufacturing process due to changes in the formulation that directly impact the formation of deposits in the equipment used (fouling). This deposit changes significantly in relation to its quantity as well as in relation to the composition and chemical characteristics as the gradual reduction of the sucrose content in the production takes place. Therefore, these impacts must be considered in order to maintain better manufacturing and ensure efficient cleaning of equipment.

The development of products with low sugar content or without sugar has become a popular strategy for the food industries and is being applied to different products such as chocolates, jams, fruit preserves and dairy products, especially yogurts (Belščak-Cvitanović *et al.*, 2015; Moore *et al.*, 2020). The rationale is to improve consumer health, particularly in relation to obesity, through reduced caloric content. Dulce de leche (DL) is a very popular dairy product due to its sweetness. It is produced from milk (fresh or reconstituted) with the addition of sucrose up to 30 g/100 mL per volume of milk (Brasil, 1997). However, the current trend is the reduction of this sucrose content in the product for the reasons just given.

Dulce de leche manufacture can be done by two types of evaporators: pan (atmospheric pressure) and vacuum evaporator (below atmospheric pressure). Pans are, in the traditional manufacturing process, the most commonly used. The production of DL starts with the addition of the syrup (milk + sugar) inside the pan with gradual heating under continuous agitation (Perrone *et al.*, 2019; Stephani *et al.*, 2019). By decreasing the sugar content in the DL, there may be an increase in fouling, typically found in the heat treatment of milk, that causes problems throughout production (Tanguy *et al.*, 2019).

The production of DL for research generates an economical expense in relation to energy and raw materials, in addition to longer manufacturing times when compared with industrial scale production lines. To avoid these problems, a process simulator as characterized in the literature was used in the laboratory resulting in quick and economical production of DL within the parameters of legislation (Stephani *et al.*, 2017). The representative results found by Francisquini *et al.* (2019) for hydrolyzed DL were considered the objective of the current work to verify the impact of the reduction of sugar in the production of DL in relation to the formation of incrustations.

Material and methods

Different levels of sucrose (20, 15, 10, 5 and 0% w/w) were added to pasteurized milk, and each syrup went through the process simulator for 1.5 h at approximately 125 °C (each concentration was done in triplicate). After the concentration period, the respective resulting deposits were removed for analysis.

The total protein analysis for each deposit was performed in duplicate using the micro Kjeldahl method (Wang *et al.*, 2016). The elemental composition (carbon, hydrogen and nitrogen) of each deposit was also analyzed in triplicate using the Pregl–Dumas method

© The Author(s), 2021. Published by Cambridge University Press on behalf of Hannah Dairy Research Foundation



CAMBRIDGE
UNIVERSITY PRESS

Influence of sucrose reduction on fouling during the production of dulce de leche

Erica F. Mauricio¹, Júlia D. A. Francisquini¹, Igor L. de Paula², José de C. C. Cezarino Junior¹, Luiz F. C. de Oliveira², Rodrigo Stephani², Antônio F. De Carvalho¹ and Ítalo T. Perrone^{3*}.

¹Department of Food Technology, Federal University of Viçosa, Brazil.

²Department of Chemistry, Federal University of Juiz De Fora, Juiz De Fora, Brazil.

³Faculty of Pharmacy, Federal University of Juiz De Fora, Juiz De Fora, Brazil.

Short title: effect of sucrose reduction on fouling in dulce de leche production

*Correspondence: Ítalo T. Perrone

Faculty of Pharmacy

Federal University of Juiz De Fora

Rua José Lourenço Kelmer, s/n

São Pedro, Juiz de Fora - MG,

36036-900

Brazil

phone +553221023893

E-mail: italotulerperrone@gmail.com

Abstract

This Research Communication combines dulce de leche (DL), a popular product from Latin America, with the food industry's broad tendency to decrease sugar content in food products and examines the influence of sucrose reduction on the detrimental deposits formed during the production process. The method used to identify the impact produced directly on the heat exchanger during the production of this product with low sucrose content required varying the quantity of sucrose in the milk. Different percentages of sucrose, 20, 15, 10, 5 and 0 % (w·w⁻¹) were submitted to the DL

concentration process in a process simulator. After concentration, the quantification of the deposits formed in each was carried out and these deposits were characterized according to their composition. Methods such as Kjeldahl, Pregl-Dumas and SEM-EDS were used. Thus, the work highlights the need to change the product manufacturing process due to changes in the formulation that directly impact the formation of deposits in the equipment used (fouling). This deposit changes significantly in relation to its quantity as well as in relation to the composition and chemical characteristics as the gradual reduction of the sucrose content in the production takes place. Therefore, these impacts must be considered in order to maintain better manufacturing and ensure efficient cleaning of equipment.

Keywords: concentration, dulce de leche (DL), reduced sugar and fouling

The development of products with low sugar content or without sugar has been a strategy currently adopted by the food industries (chocolates, jams, fruit jams, yogurts) (Belščak-Cvitanović *et al.*, 2015; Moore *et al.*, 2020).

Dulce de leche (DL) is a very popular dairy product due to its sweetness. It is produced from milk (fresh or reconstituted) with the addition of sucrose up to $30 \text{ g} \cdot 100 \text{ mL}^{-1}$ per volume of milk (BRASIL, 1997). However, the current trend is the reduction of this sucrose content in the product mainly for health reasons.

Its manufacture can be done by two types of evaporators: pan (atmospheric pressure) and vacuum evaporator (below atmospheric pressure). Pans are, in the traditional manufacturing process, the most commonly used. The production of DL starts with the addition of the syrup (milk + sugar) inside the pan with gradual heating under continuous agitation (Perrone *et al.*, 2019; Stephani *et al.*, 2019).

By decreasing the sugar content in the DL, there may be an increase in fouling, typically found in the heat treatment of milk, that causes problems throughout production (Tanguy *et al.*, 2019).

The production of DL for research generates an economical expense in relation to energy and raw materials, in addition to longer manufacturing times when compared with industrial scale production lines. To avoid these problems, a process simulator as characterized in the literature was used in the laboratory resulting in quick and economical production of DL within the parameters of legislation (Stephani *et al.*, 2017). The representative results found by Francisquini *et al.* (2019) for hydrolyzed DL

was considered the objective of the current work to verify the impact of the reduction of sugar in the production of DL in relation to the formation of incrustations.

Material & Methods

Pasteurized milk was added with different levels of sucrose (20, 15, 10, 5 and 0 % w·w⁻¹), and each syrup went through the process simulator for 1.5 h at approximately 125 °C (each concentration was done in triplicate). After the concentration period, the respective resulting deposits were removed for analysis.

The total protein analysis for each deposit was performed in duplicate using the micro Kjeldahl method (Wang, Pampati, McCormick, & Bhattacharyya, 2016). The elemental composition (carbon, hydrogen and nitrogen) of each deposit was also analyzed in triplicate using the Pregl-Dumas method (Patterson, 1973). Further, their anions were quantified to determine calcium and phosphorus with semiquantitative analysis using SEM-EDS and quantitative analysis using the AOAC methodology (2012). The morphological analysis was performed using scanning electron microscopy with 500x magnification and Raman spectroscopy and followed the methodology proposed by (Rodrigues Júnior *et al.*, 2016) and was performed in duplicate.

Regarding statistical analyses, Pearson's correlation coefficient was calculated according to the formula in Microsoft Excel. And for Tukey's analysis, the data obtained from the analysis of the deposits an ANOVA was performed. If the F value indicated a difference between the means, the normality and homogeneity of the data was analyzed using the Shapiro-Wilk and Bartlett tests, respectively, and both tests at 5 % significance. Finally, Tukey's analysis was used to identify group differences.

More detailed information about material and methods is described in the supplementary file.

Results and discussion

This section will specifically deal with the deposits formed during the production of DL, as these are related to the frequency of use and cleaning of the equipment, which directly impacts production capacity. Thus, the quantitative and morphological observations of the deposits (Figure 1) and the main results (Table 1) obtained through the analyses described in the previous section will be discussed.

Concentration of Milk

After the end of the concentration, the increase in the formation of deposits is visually noticeable with decreased sugar content (Figure 1A).

Physical-chemical characterization of deposits

By keeping the amount of milk at 1000 g for all samples, it is possible to infer that the amount of milk components is the same for all samples; however, the addition of sucrose causes a dilution effect of these constituents. In the manufacture of traditional DL with 20% ($\text{m}\cdot\text{m}^{-1}$) of sucrose, this dilution factor comes to 16.67. By decreasing the sucrose content, this factor also gradually decreases to 13.04, 9.09, 4.76 and 1.00 for the levels of 15%, 10%, 5% and 0%, respectively (Table 1).

In addition to this factor, there is also an increase in the evaporative capacity of the samples in line with a decrease in the addition of sugar, from $58.02 \pm 1.55\%$ ($\text{m}\cdot\text{m}^{-1}$) of evaporated water for traditional DL to $72.88 \pm 0.67\%$ ($\text{m}\cdot\text{m}^{-1}$) for milk without added sugar (Table 1), leading to an increase of evaporation 1.26 times. Therefore, the production requires a shorter evaporation time to achieve the desired characteristics. This fact is corroborated by the concentration factor that increases by 1.67 times. However, despite this benefit, when concentrating the product with low sucrose content, there is an increase in the content of deposits formed that can reach up to approximately 13 times (ratio between the %deposit ($\text{w}\cdot\text{w}^{-1}$) – 20% sucrose:0% sucrose) more than in the traditional product. In addition, the composition of the deposits changes, moving from a deposit with greater dry extract (81.57% $\text{m}\cdot\text{m}^{-1}$) to a deposit with greater moisture content (54.23% $\text{m}\cdot\text{m}^{-1}$) as sugar is decreased. This factor is linked to its composition because when the sucrose content decreases, the deposits start to have a higher protein content. This is responsible for greater water retention and thereby increasing the moisture content of the collected deposits. This factor is corroborated by correlating the levels of total protein and protein in the dry base with the moisture content in which Pearson correlations of $r(3) = .987$, $p = .002$ and $r(3) = .997$, $p < .001$ are obtained, respectively, clearly showing the relationship between these parameters in the samples.

When analyzing the chemical composition of the deposits (Table 1), once again, a change in the composition of the deposit is observed. The decrease in sugar content from 20 to 0 % implies an increasing portion of proteins in the samples, from $12.94 \pm$

1.79 to $31.31 \pm 2.66\%$ ($\text{m}\cdot\text{m}^{-1}$) on dry basis respectively, and a subsequent greater water retention (Table 1). Upon the analysis of minerals (calcium and phosphorus), the semiquantitative analysis by EDS shows a behavior with increasing (3.99 ± 0.01 to 10.61 ± 0.02 , for calcium and 2.58 ± 0.01 to 6.61 ± 0.12 , for phosphorus – Table 1) statistical significance by the Tukey test ($p < 0.05$) of the contents of these minerals when reducing sucrose. The same behavior is observed when performing the quantitative analysis by means of atomic absorption spectroscopy obtaining the following values: for calcium 371, 580, 837, 1060, 1117 $\text{mg}\cdot 100 \text{ g}^{-1}$ and for phosphorus 288, 410, 571, 709 and 786 $\text{mg}\cdot 100 \text{ g}^{-1}$ for samples with sucrose addition of 20, 15, 10, 5 and 0 % ($\text{m}\cdot\text{m}^{-1}$), respectively. This occurs since the concentration causes a destabilization in the casein micelles and then once the high temperature causes calcium phosphate to precipitate and, therefore, increases the probability of these salts adhering to the surface wall (Mekmene, Le Graët & Gaucheron, 2009).

Scanning electron microscopy (SEM)

Figure 1B showed the surface aspect of the deposits. In the production of traditional DL we observed a deposit, in its non-freeze-dried form (B1), compact and smooth; when removing water from it utilizing freeze-drying (B2), some crystals were present. With the total removal of sucrose, the concentration of milk forms more rough deposits when observed in its non-lyophilized form (B3) and when lyophilizing it (B4), we can observe a spongy structure characteristic of proteins (Hagsten et al., 2016).

Raman spectroscopy

Deposits formed during the concentration of milks at 0% and 20% ($\text{m}\cdot\text{m}^{-1}$) sucrose were analyzed using Raman spectroscopy. The spectra obtained (respectively C1 and C2 in Figure 2C) showed they have a similar overall shape, which is due to the same milk-based composition. However, the C2 spectrum shows bands with smaller FWHM values (full width at half maximum) that were not observed in C1; such band forms are characteristic of crystalline structures, as seen in Figure 1B (B2). In the same way, commercial sucrose was also analyzed using Raman spectroscopy (spectrum C3 in Figure 1C) and according to (Brizuela et al., 2012), the specific bands attributed to sucrose characteristic vibrational modes are visible at 850, 642, 526 and 403 cm^{-1} . These bands are visible on both spectra C3 and C2, which confirms that the

crystals observed in Figure B2 are made from sucrose. It is interesting to note that due to its lower concentration of proteins and sucrose in its composition, and being highly soluble in water, such deposits tend to be easily removed from the surface, unlike milk protein-rich systems (Hagsten *et al.*, 2016).

Scientific articles corroborating the results and more detailed information about results and discussion are in the supplementary file.

Conclusions

With the reduction of the sugar content in the manufacture of DL, attention must be paid to the concentration-time, since it will occur faster due to the increase in the evaporative capacity. As to the cleaning intervals of the equipment, it will require more frequent cleaning cycles due to the possible shorter usage cycle time of the equipment and the need for a more rigorous cleaning regimen to remove proteins adhered to the heat exchange surface (Hagsten *et al.*, 2016).

Acknowledgment: This work was supported by Brazilian foundations (FAPEMIG, CNPq and CAPES).

References

- Belščak-Cvitanović A, Komes D, Dujmović M, Karlović S, Biškić M, Brnčić M & Ježek D 2015 Physical, bioactive and sensory quality parameters of reduced sugar chocolates formulated with natural sweeteners as sucrose alternatives. *Food Chemistry* **167** 61–70
- BRASIL 1997 Ministério da Agricultura, Pecuária e Abastecimento Portaria n. 354, de 04 de setembro de 1997. Regulamento técnico de identidade e qualidade de doce de leite. *Diário Oficial Da República Federativa Do Brasil* 37–38.
- Brizuela AB, Bichara LC, Romano E, Yurquina A, Locatelli S & Brandán, SA 2012 A complete characterization of the vibrational spectra of sucrose. *Carbohydrate Research* **361** 212–218
- Francisquini JDA, Rocha J, Martins E, Stephani R, da Silva PHF, Renhe IRT, Perrone ÍT & de Carvalho AF 2019 5-Hydroxymethylfurfural formation and color

- change in lactose-hydrolyzed Dulce de leche. *Journal of Dairy Research* **86** (4) 477–482
- Hagsten, C., Altskär, A., Gustafsson, S., Lorén, N., Hamberg, L., Innings, F., ... Nylander, T. (2016). Composition and structure of high temperature dairy fouling. *Food Structure*, *7*, 13–20. <https://doi.org/10.1016/j.foostr.2015.12.002>
- Mekmene, O., Le Graët, Y., & Gaucheron, F. (2009). A model for predicting salt equilibria in milk and mineral-enriched milks. *Food Chemistry*, *116*(1), 233–239. <https://doi.org/10.1016/j.foodchem.2009.02.039>
- Moore JB, Sutton EH & Hancock N 2020 Sugar reduction in yogurt products sold in the UK between 2016 and 2019. *Nutrients*, **12** (171) 12
- Patterson, R. K. (1973). Automated Pregl-Dumas Technique for Determining Total Carbon, Hydrogen, and Nitrogen in Atmospheric Aerosols. *Analytical Chemistry*, *45*(3), 605–609. <https://doi.org/10.1021/ac60325a050>
- Perrone IT, Stephani R, de Carvalho AF, Netto GG & Francisquini, JDA 2019 *Doce de leite: química e Tecnologia*. São Paulo: CAP-LAB.
- Rodrigues Júnior PH, Oliveira KDS, Almeida CERD, de Oliveira LFC, Stephani R, Pinto MDS, de Carvalho AF & Perrone ÍT 2016 FT-Raman and chemometric tools for rapid determination of quality parameters in milk powder: Classification of samples for the presence of lactose and fraud detection by addition of maltodextrin. *Food Chemistry* **196** 584–588
- Stephani R, Francisquini JDA, Perrone ÍT, de Carvalho AF & de Oliveira LFC 2019 Dulce de Leche—Chemistry and Processing Technology. In *Milk Production, Processing and Marketing* (p. 18). IntechOpen.
- Stephani R, Francisquini JDA, de Paula IL, de Carvalho AF, de Oliveira LFC & Perrone ÍT 2017 Simulation of Water Evaporation on Ultimotored Thermomix®: Potential Approach for Studies on Milk Evaporation. *Revista Do Instituto de Laticínios Cândido Tostes* **72** (4) 227–235
- Tanguy G, Perrone IT, Dolivet A, Santellania AC, Leduc A, Jeantet R, Schuck P & Gaucheron F 2019 Calcium citrate insolubilization drives the fouling of falling film evaporators during the concentration of hydrochloric acid whey. *Food Research International* **116** 175–183
- Wang, H., Pampati, N., McCormick, W. M., & Bhattacharyya, L. (2016). Protein Nitrogen Determination by Kjeldahl Digestion and Ion Chromatography. *Journal*

of Pharmaceutical Sciences, 105(6), 1851–1857.

<https://doi.org/10.1016/j.xphs.2016.03.039>

Figure legends:

Figure 1:

- A)** Deposits formed after the manufacture of DL according to the sucrose content added to the milk, where: (A1) Empty, (A2) 20% ($\text{m}\cdot\text{m}^{-1}$) sucrose – DL, (A3) 15% ($\text{m}\cdot\text{m}^{-1}$) sucrose, (A4) 10% ($\text{m}\cdot\text{m}^{-1}$) sucrose, (A5) 5% ($\text{m}\cdot\text{m}^{-1}$) sucrose and (A6) 0% ($\text{m}\cdot\text{m}^{-1}$) sucrose.
- B)** SEM analysis of the samples with 500x magnification. Where (B1) 20% ($\text{m}\cdot\text{m}^{-1}$) sucrose non-freeze-dried, (B2) 20% ($\text{m}\cdot\text{m}^{-1}$) sucrose freeze-dried, (B3) 0% ($\text{m}\cdot\text{m}^{-1}$) sucrose non-freeze-dried and (B4) 0% ($\text{m}\cdot\text{m}^{-1}$) sucrose freeze-dried.
- C)** FT-Raman spectroscopy analysis. Being (C1) 0% ($\text{m}\cdot\text{m}^{-1}$) sucrose freeze-dried, (C2) 20% ($\text{m}\cdot\text{m}^{-1}$) sucrose freeze-dried and (C3) commercial sucrose.

Figure 1:

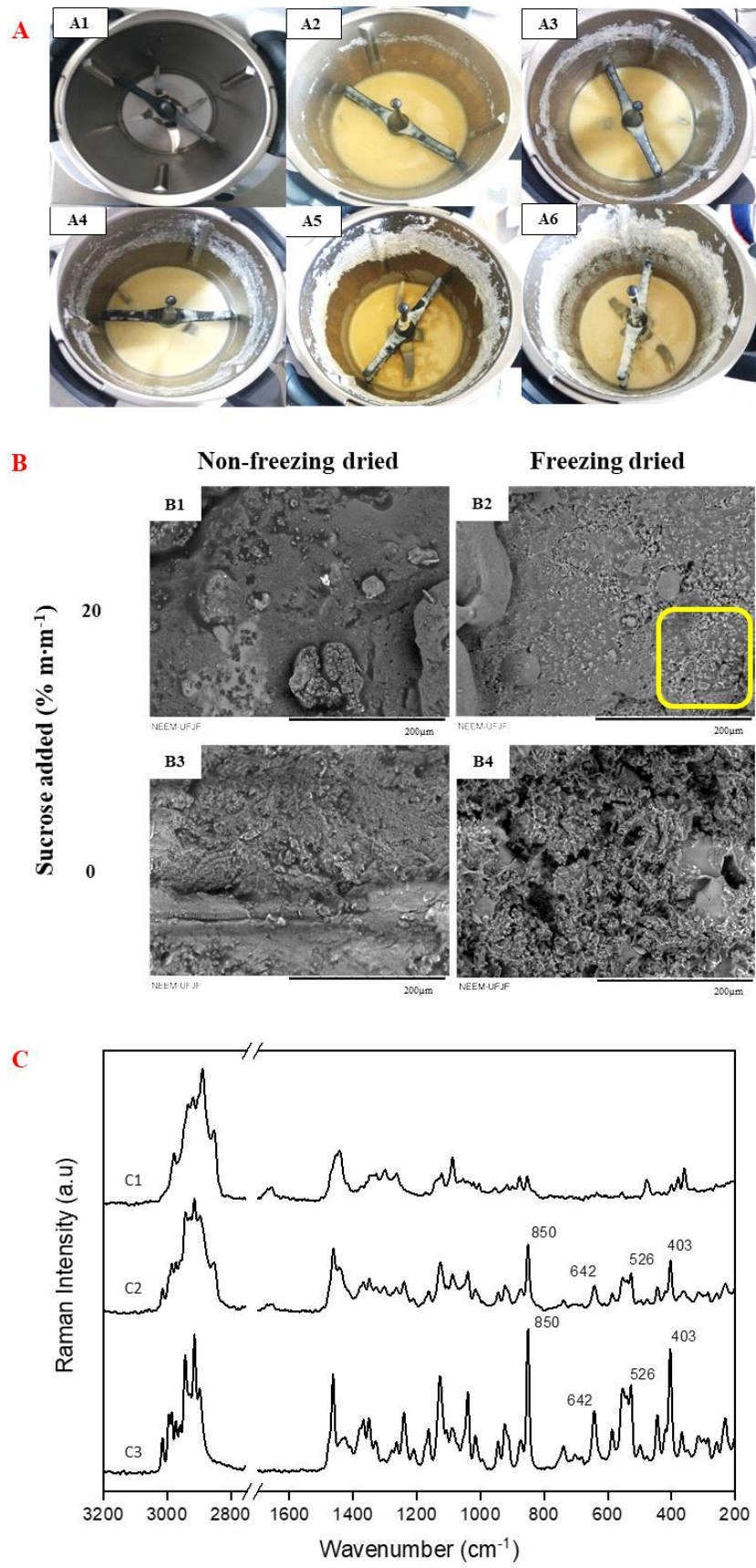

Table legend:**Table 1:** Composition and chemical characterization of the deposits formed on the equipment in relation to the sucrose content added to whole milk.

Parameters	Sucrose added (% w·w ⁻¹)				
	20	15	10	5	0
Dilution factor	16.67 ± 0.01	13.04 ± 0.01	9.09 ± 0.01	4.76 ± 0.00	1.00 ± 0.00
Evaporated water (% w·w ⁻¹)	58.02 ± 1.55	59.14 ± 0.58	59.91 ± 2.09	68.62 ± 4.38	72.88 ± 0.67
Evaporation Ratio	2.39 ± 0.09	2.46 ± 0.03	2.52 ± 0.13	3.33 ± 0.50	4.00 ± 0.08
Deposit (% w·w ⁻¹)	0.16 ± 0.03 ^a	0.18 ± 0.03 ^a	0.39 ± 0.03 ^a	1.39 ± 0.15 ^b	2.15 ± 0.19 ^c
Total Protein (% w·w ⁻¹)	10.55 ± 1.46 ^a	11.22 ± 2.76 ^a	14.14 ± 1.16 ^a	13.87 ± 1.35 ^a	14.33 ± 1.22 ^a
Protein on dry basis (% w·w ⁻¹)	12.94 ± 1.79 ^a	14.65 ± 3.60 ^a	26.05 ± 2.13 ^a	27.07 ± 2.64 ^b	31.31 ± 2.66 ^b
g H ₂ O·g protein ⁻¹	1.75 ± 0.25 ^a	2.09 ± 0.51 ^a	3.23 ± 0.26 ^a	3.51 ± 0.36 ^a	3.78 ± 0.33 ^a
Carbon (%)	41.77 ± 0.36 ^d	49.04 ± 0.06 ^a	46.47 ± 0.26 ^c	47.96 ± 1.00 ^{ab}	47.24 ± 0.15 ^{bc}
Hydrogen (%)	6.81 ± 0.01 ^d	7.89 ± 0.02 ^a	7.61 ± 0.02 ^{bc}	7.74 ± 0.02 ^{ab}	7.48 ± 0.20 ^c
Nitrogen (%)	1.47 ± 0.02 ^a	3.14 ± 0.02 ^b	3.35 ± 0.09 ^c	3.73 ± 0.01 ^d	4.99 ± 0.07 ^e
Calcium (norm. wt. %) *	3.99 ± 0.01 ^a	7.30 ± 0.03 ^b	6.81 ± 0.02 ^c	8.67 ± 0.01 ^d	10.61 ± 0.02 ^e
Phosphorus (norm. wt. %) *	2.58 ± 0.01 ^a	3.76 ± 0.01 ^b	3.90 ± 0.01 ^c	4.58 ± 0.07 ^d	6.61 ± 0.12 ^e
Ca·P ⁻¹	1.55 ± 0.01 ^a	1.94 ± 0.01 ^a	1.75 ± 0.01 ^a	1.89 ± 0.03 ^a	1.61 ± 0.03 ^a

* Semiquantitative analysis performed by EDS.

** Same letters on the same line do not show significant difference by Tukey's test ($p < 0.05$).

2.1. Supplementary file of paper 1

Influence of sucrose reduction on fouling during the production of dulce de leche

Erica F. Mauricio¹, Júlia D. A. Francisquini¹, Igor L. de Paula², José de C. C. Junior¹, Luiz F. C. de Oliveira², Rodrigo Stephani², Antônio F. de Carvalho¹ and Ítalo T. Perrone^{3*}.

Introduction

Products with low sugar content are justified by recent studies correlating the decrease in dietary sugar (mainly sucrose) with the prevention, combat and recovery of a series of pathologies such as diabetes, hypertension, obesity, cardiovascular diseases, metabolic syndrome, dementia, depression, anxiety, cancer, dental problems, ulcers, hiatal hernia, Crohn's disease, irritable bowel syndrome, dermatitis, liver disease (Chow, 2017; Della Corte *et al.*, 2018; Khan & Sievenpiper, 2016; Lenne & Mann, 2020). These products with low content or without sugar meet the demand for healthy foods, however they can present different functional, rheological, sweetness, stability, particle size distribution and texture when compared to traditional products, thus needing to use other compounds that provide body, texture and sweetness to it (Belščak-Cvitanović *et al.*, 2015).

In order to avoid the problems associated with excessive sugar intake and to meet the growing demand of consumers for a healthier lifestyle, the dairy industries have made use of these new standards and concerns to manufacture products such as dulce de leche, chocolate, ice cream and yogurt with low sugar content (Castanheira, 2012; McCain *et al.*, 2018; Moore *et al.*, 2020). Nutritionally, dulce de leche (DL) has high energy value and high concentration of proteins, minerals, fats and carbohydrates (BRASIL, 1997; Francisquini *et al.*, 2018; Stephani *et al.*, 2019). Normally, the pans for the production of DL are simple to operate and maintain, being made of stainless steel with a double wall through which the steam circulates and an agitator shaft. This has the purpose of preventing the portion of the liquid in direct contact with the equipment walls from burning (modifying the sensory characteristic of the product) or forming incrustations (fouling) along the concentration in addition to causing the temperature to be homogenous thus facilitating the evaporation of water. Upon reaching the desired

point the product must be cooled and packaged (Perrone *et al.*, 2019; Stephani *et al.*, 2019).

With the heat treatment of milk, two types of inlays can occur in the pan: type A (formed mostly by proteins with a soft, white appearance) and type B (formed mostly from minerals, being more compact and grayer) (Bansal & Chen, 2006). As they differ in composition, it is necessary to use different cleaning processes to efficiently remove each type of deposit (Fickak *et al.*, 2011; Goode *et al.*, 2013; Jeurink & Brinkman, 1994; Morison & Thorpe, 2002). When adding sugar to milk, in the manufacture of DL, there is a reduction in the occurrence of these incrustations, since there is an increase in the surface tension of water and in the chemical potential of proteins, favoring the state of lower surface of the proteins (native protein). Moreover, the addition of sugar causes rheological and kinetic changes that interfere with protein-protein interactions (Baier *et al.*, 2004; Kendrick *et al.*, 1997). Thus, the traditional DL industry does not present considerably many cases of encrustation, but when it comes to dulce de leche with low sugar content, changes in the product occur and they can lead to the formation of deposits on the equipment. These fouling can result in loss of productivity, in loss of the thermal exchange efficiency, in pressure drop in the equipment and in increase of additional costs related to cleaning products and energy (Gandhi *et al.*, 2017; Tanguy *et al.*, 2019; 2016).

Material & methods

Deposit formation

Pasteurized whole milk used was purchased in the local market (Viçosa, Brazil). The temperature of the inlet product was 4 °C and added with different sucrose contents (0%, 5%, 10%, 15% and 20% (w·w⁻¹)). This process ensured the same protein content of all blends since for all the mixtures the same amount of milk was weighed and only then added the sucrose according to the desired percentages. The samples were concentrated in a laboratory scale atmospheric pressure evaporator (process simulator) (Vorwerk Thermomix TM5) nearly at 125 °C for 90 min with 1 g (centrifugal force) of rotation. The deposits formed were collected after the end of the concentration by scraping the surface of the equipment - mass of deposit - and weighed in analytical

balance (BEL engineering® Mark 214). For the characterization of the deposits, was performed dehydration using the freeze-drying method (Labconco - Freezone 2.5 Plus) with temperature $-88\text{ }^{\circ}\text{C}$ and pressure 0.014 mbar. This method was used to standardize the samples.

Characterization of deposits

Total protein

Total nitrogen from each deposit formed from the different samples was determined by using the micro Kjeldahl method, according the AOAC 982.38 method, it is an indirect methodology because when considering a conversion factor of 6.38 it is possible to estimate the protein contents (Wang *et al.*, 2016), the results were expressed in % dry basis.

Moisture and dry matter

The moisture content was measured by using 1.90 ± 0.05 g of each deposit and a thermogravimetric balance (Sartorius® MA150). The total solids content was obtained by percentage difference of the moisture content found and with this percentage is possible to calculate the dry extract.

Carbon, Hydrogen and Nitrogen

The Elemental Analysis was performed by means of an elemental analyzer (Perkin Elmer 2400 series ii) to determine the percentages of carbon, hydrogen, and nitrogen of the samples of the deposits formed in the evaporator. This analysis is based on the Pregl-Dumas method whose samples are subjected to combustion in an atmosphere of pure oxygen and the gases resulting from this combustion are quantified in a TCD detector (thermal conductivity detector).

Calcium and Phosphorus

For the analysis of the trend of calcium and phosphorus content in the deposits it has been used a semi-quantitative analysis by energy dispersive spectrophotometer – EDS (HITACHI® TM3000).

And for quantitative analysis, the methods used were carried out according to the methodology of AOAC (2012), as official methods 985.35 using flame atomic absorption spectroscopy (FAAS) and 984.27 using inductively coupled plasma-atomic emission spectrometry (ICP-AES) for the calcium and phosphorus analyzes, respectively.

Scanning electron microscopy

Samples of deposits were analyzed by scanning electron microscopy – SEM (HITACHI® TM3000) with increase of 500x.

FT-Raman spectroscopy

Fourier-transform Raman spectrometer (Bruker, RFS 100/S) with a germanium detector using liquid nitrogen as coolant and with 1064 nm excitation from a Nd:YAG laser was used to characterize the deposits according to their dispersive ability. A few milligrams of the sample were placed into a small aluminum sample cup, the laser light with a power of 20 mW was introduced and focused on the sample, then the scattered radiation was collected at 180°. For each spectrum an average of 512 scans were performed at a resolution of 4 cm⁻¹, over the 4000–50 cm⁻¹ range. The OPUS 6.0 (Bruker Optik, Ettlingen, Germany) software program was used for Raman data acquisition (Almeida, Oliveira, Stephani & De Oliveira, 2011; Rodrigues Júnior et al., 2016).

Results and discussion

Concentration of Milk

Corroborating with Figure 1, the same is seen after weighing the deposits, which goes from 1.9 g to 21.5 g in the mix with 20% m·m⁻¹ of sucrose and without added sucrose, respectively, which represents an increase of more than 11 times in incrustation.

Physical-chemical characterization of deposits

When calculating the water-protein ratio of the deposits, it has been observed that with the decrease in the sucrose content there is a greater water retention by the proteins

reaching approximately $4 \text{ g H}_2\text{O}\cdot\text{g prote\~{i}na}^{-1}$ corroborating with the literature (Walstra, Wouters, & Geurts, 2006).

It is still possible to say that the relationship between the lower content of deposits in the production of traditional DL is not only related to the dilution of milk constituents by the addition of sucrose, since the increase in deposits does not evolve in the same proportion as the decrease of the dilution factor, thus indicating the protective effect of sucrose amidst the concentration of the product (de Jong *et al.*, 1992).

Regarding the low content of calcium and phosphorus in the deposit resulting from the product with greater sucrose addition, it corroborates with the previous results and indicates that sucrose stabilizes milk proteins (Lee & Timasheff, 1981). As the relationship between calcium and phosphorus ($\text{Ca}\cdot\text{P}^{-1}$) remains around 1.75, with no statistically significant difference by the Tukey test ($p < 0.05$) for different sucrose levels, this indicates that despite the increase in minerals in the deposit, these are precipitated in the same proportion, therefore, the phosphate ester groups of the caseins together with the bound calcium are assumed not to be part of the calcium phosphate matrix, thus being of the tricalcium phosphate type (Gaucheron, 2005).

Pearson's correlation was used in order to observe whether the interactions between the analyzes performed and the variables of the experiment (added sucrose content, dilution factors and concentration) were significant. Based on Table S1, it is possible to observe that the relationship between calcium and phosphorus does not present a statistically significant correlation to the analyzed parameters. However, all other variables are statistically significant in relation to the added sucrose content and to the dilution factor. But when analyzing in relation to the concentration factor, it is observed that the percentage of total protein is not significant as it is in relation to the dilution factor, therefore it is possible to conclude that the concentration, despite influencing proteins, the addition of sugar ends up generating a protective effect on them that is removed by completely eliminating sucrose from milk.

Scanning Electron Microscopy

The deposit observed in Figure A1 indicates Type A deposits (Burton, 1968), that is, with high protein content, which goes with the other analyzes carried out and that show the relationship between the decrease in sucrose and the increase in proteins (from 12.94 to 31.31% (w·w⁻¹) of protein on a dry basis for deposits with the addition of 20

and 0% (w·w⁻¹) of sucrose, respectively) and also to the increase in moisture present in this type of deposit (going from 18.43 to 54.23% humidity for deposits with addition of 20 and 0% (w·w⁻¹) sucrose, respectively), once the rough structure is able to retain more water than the compact structure of the deposit formed in production of traditional DL. A change in the quantity and structure of the deposits with the addition of sucrose is also observed by Zhang *et al.* (2018). Besides, this structure shows that the adopted cleaning procedures must be different, since the protein deposit requires specific cleaning and specific chemical products in a certain sequence: first the alkaline solution for the removal of the protein layer (top) and then the acidic solution for the removal of the innermost layer - minerals (Jeurnink & Brinkman, 1994).

Raman spectroscopy

In C2 (dulce de leche) and C3 (sucrose) spectra it is possible to perceive some of the main marking bands of sucrose, such as the band observed at 850 cm⁻¹ referring to the vibrational deformation mode of CH₂, the bands at 642 and 523 cm⁻¹, referring to the deformation modes of the glucopyran ring, and the 403 cm⁻¹ band, referring to a coupled mode to the sum of the deformation modes of the O39-C32-C31 bond and to the deformation of the C37-C31-O27 group of the glucopyran ring (Brizuela *et al.*, 2012).

References

- Almeida MR, Oliveira KDS, Stephani R & de Oliveira LFC 2011 Fourier-transform Raman analysis of milk powder: A potential method for rapid quality screening. *Journal of Raman Spectroscopy* **42** (7) 1548–1552
- Baier SK, Decker EA & McClements DJ 2004 Impact of glycerol on thermostability and heat-induced gelation of bovine serum albumin. *Food Hydrocolloids* **18** (1) 91–100
- Bansal B & Chen XD 2006 A critical review of milk fouling in heat exchangers. *Comprehensive Reviews in Food Science and Food Safety* **5** 27–33
- Belščak-Cvitanović A, Komes D, Dujmović M, Karlović S, Biškić M, Brnčić M & Ježek D 2015 Physical, bioactive and sensory quality parameters of reduced sugar

- chocolates formulated with natural sweeteners as sucrose alternatives. *Food Chemistry* **167** 61–70
- BRASIL 1997 Ministério da Agricultura, Pecuária e Abastecimento. Portaria n. 354, de 04 de setembro de 1997. Regulamento técnico de identidade e qualidade de doce de leite. *Diário Oficial Da República Federativa Do Brasil* 37–38.
- Brizuela AB, Bichara LC, Romano E, Yurquina A, Locatelli S & Brandán, SA 2012 A complete characterization of the vibrational spectra of sucrose. *Carbohydrate Research* **361** 212–218
- Castanheira ACG 2012 *Controle de Qualidade de Leite e Derivados (2ª)*. São Paulo: Cap Lab Indústria e Comércio Ltda.
- Chow KF 2017 A Review of Excessive Sugar Metabolism on Oral and General Health. *The Chinese Journal of Dental Research : The Official Journal of the Scientific Section of the Chinese Stomatological Association (CSA)* **20** (4) 193–198
- de Jong P, Bouman S & Van Der Linden HJLJ 1992 Fouling of heat treatment equipment in relation to the denaturation of b-lactoglobulin. *International Journal of Dairy Technology* **45** (1) 3–8
- Della Corte KW, Perrar I, Penczynski KJ, Schwingshackl L, Herder C & Buyken AE 2018 Effect of dietary sugar intake on biomarkers of subclinical inflammation: A systematic review and meta-analysis of intervention studies. *Nutrients* **10** (5)
- Fickak A, Al-Raisi A & Chen XD 2011 Effect of whey protein concentration on the fouling and cleaning of a heat transfer surface. *Journal of Food Engineering* **104** (3) 323–331
- Francisquini JDA, Neves LNO, Torres JKF, de Carvalho AF, Perrone IT & da Silva PHF 2018 Physico-chemical and compositional analyses and 5-hydroxymethylfurfural concentration as indicators of thermal treatment intensity in experimental dulce de leche. *Journal of Dairy Research* **85** (4) 476–481
- Gandhi G, Amamcharla JK & Boyle D 2017 Effect of milk protein concentrate (MPC80) quality on susceptibility to fouling during thermal processing. *LWT - Food Science and Technology* **81** 170–179
- Gaucheron F 2005 The minerals of milk. *Reproduction Nutrition Development* **45** 473–483

- Goode KR, Asteriadou K, Robbins PT & Fryer PJ 2013 Fouling and cleaning studies in the food and beverage industry classified by cleaning type. *Comprehensive Reviews in Food Science and Food Safety* **12** (2) 121–143
- Jeurnink TJM & Brinkman DW 1994 The cleaning of heat exchangers and evaporators after processing milk or whey. *International Dairy Journal* **4** (4) 347–368
- Kendrick BS, Chang BS, Arakawa T, Peterson B, Randolph TW, Manning MC & Carpenter JF 1997 Preferential exclusion of sucrose from recombinant interleukin-1 receptor antagonist: Role in restricted conformational mobility and compaction of native state. *Proceedings of the National Academy of Sciences* **94** (22) 11917–11922
- Khan TA & Sievenpiper JL 2016 Controversies about sugars: results from systematic reviews and meta-analyses on obesity, cardiometabolic disease and diabetes. *European Journal of Nutrition* **55**, 25–43
- Lee JC & Timasheff SN 1981 The Stabilization of Proteins by Sucrose. *The Journal of Biological Chemistry* **256** (14) 7193–7201
- Lenne RL & Mann T 2020 Reducing sugar use in coffee while maintaining enjoyment: A randomized controlled trial. *Journal of Health Psychology* **25** (5) 586–597
- McCain HR, Kaliappan S & Drake MA 2018 Invited review: Sugar reduction in dairy products. *Journal of Dairy Science* **101** (10) 8619–8640
- Moore JB, Sutton EH & Hancock N 2020 Sugar reduction in yogurt products sold in the UK between 2016 and 2019. *Nutrients* **12** (171) 12
- Morison KR & Thorpe RJ 2002 Spinning disc cleaning of skimmed milk and whey protein deposits. *Trans IChemE* **80** (December) 319–325
- Perrone IT, Stephani R, de Carvalho AF, Netto GG & Franicsquini JDA 2019 *Doce de leite: química e Tecnologia*. São Paulo: CAP-LAB.
- Rodrigues Júnior PH, Oliveira KDS, de Almeida CER, de Oliveira LFC, Stephani R, Pinto MDS, de Carvalho AF & Perrone ÍT 2016 FT-Raman and chemometric tools for rapid determination of quality parameters in milk powder: Classification of samples for the presence of lactose and fraud detection by addition of maltodextrin. *Food Chemistry* **196** 584–588

- Stephani R, Francisquini JDA, Perrone ÍT, de Carvalho AF & de Oliveira LFC 2019 Dulce de Leche—Chemistry and Processing Technology. In *Milk Production, Processing and Marketing* (p. 18). IntechOpen.
- Tanguy G, Perrone IT, Dolivet A, Santellania AC, Leduc A, Jeantet R, Schuck P & Gaucheron F 2019 Calcium citrate insolubilization drives the fouling of falling film evaporators during the concentration of hydrochloric acid whey. *Food Research International* **116** 175–183
- Tanguy G, Siddique F, Beaucher E, Santellani AC, Schuck P & Gaucheron F 2016 Calcium phosphate precipitation during concentration by vacuum evaporation of milk ultrafiltrate and microfiltrate. *LWT - Food Science and Technology* **69** 554–562
- Walstra P, Wouters JTM & Geurts TJ 2006 *Dairy Science and Technology* (Second). Taylor & Francis Group
- Wang H, Pampati N, McCormick WM & Bhattacharyya L 2016 Protein Nitrogen Determination by Kjeldahl Digestion and Ion Chromatography. *Journal of Pharmaceutical Sciences* **105** (6) 1851–1857
- Zhang BY, Lu J & Huang JY 2018 Effect of sugar on the fouling behavior of whey protein. *Food and Bioproducts Processing* 1–8.

Table legends:**Table 1:** Pearson correlations between the analyzed parameters and the sucrose content, dilution factor and evaporation rate in the manufacture of DL.

	Sucrose added (% w·w⁻¹)	Dilution Factor	Evaporation Ratio
Deposit (% w·w ⁻¹)	-0.942	-0.948	0.997
Moisture (% w·w ⁻¹)	-0.953	-0.952	0.793
Total protein (% w·w ⁻¹)	-0.901	-0.897	0.687
Protein on dry basis (% w·w ⁻¹)	-0.957	-0.956	0.815
Nitrogen (%)	-0.953	-0.945	0.846
Calcium (norm. Wt. %)	-0.920	-0.926	0.997
Phosphorus (norm. Wt. %)	-0.902	-0.906	0.987
Ca·P ⁻¹	-0.062	-0.053	-0.157
Calcium (mg·100g ⁻¹)	-0.984	-0.984	0.855
Phosphorus (mg·100g ⁻¹)	-0.994	-0.995	0.887
Ca·P ⁻¹	-0.691	-0.683	0.386

3. PAPER 2

MAURÍCIO, Érica Felipe *et al.* Comparison of experimental setups for the production of milk concentrates and subsequent characterization. **LWT - Food Science and Technology**, v. 151, n. 112193, 2021.



Comparison of experimental setups for the production of milk concentrates and subsequent characterization

Érica Felipe Maurício^{a,b}, Gaëlle Tanguy^a, Cécile Le Floch-Fouéré^a, Eric Beaucher^a, Anne Dolivet^a, Antonio Fernandes de Carvalho^b, Ítalo Tuler Perrone^{c,*}

^a STLO, INRAE, INSTITUT AGRO, 35042, Rennes, France

^b Federal University of Viçosa, Department of Food Technology, Avenida Peter Henry Rolfs, s/n - Campus Universitário, 36570-000, Viçosa, Minas Gerais, Brazil

^c Federal University of Juiz de Fora, Department of Pharmacy, Rua José Lourenço Kelmer, s/n - Campus Universitário, Bairro São Pedro, 36038-900, Juiz de Fora, Minas Gerais, Brazil

ARTICLE INFO

Keywords:

Concentrate milk
Sweetened concentrated milk
Falling film evaporator
Rotary evaporator
Vacuum concentration

ABSTRACT

Vacuum concentration is an intermediary step in the dairy powder production and an essential step in the process scheme for the production of sweetened concentrated milk, a product widely popular and produced in Brazil. As any food product, it is subject to research and development in order to improve the original recipe and propose new derivatives, whether in academic or industrial environments. The tests required for the development of products may be costly in relation to the supply in raw material and cleaning agents, energy and water consumptions as well as water treatment after the cleaning of the equipment. As part of the reduction of production costs and environmental impact, the present work aims to evaluate the possibility of using smaller equipment for concentration as well as to produce relevant data on the processing of SCM. Two types of vacuum evaporators were used for this work: a pilot scale falling film evaporator and a lab scale rotary evaporator. Based on the observed results, it was possible to evidence the similarity of the data obtained for the concentrates (with and without sucrose addition) in both equipment for the measurements of density, viscosity and surface tension with deviations less than 10%.

1. Introduction

Vacuum concentration is used mainly for the production of powders in the dairy industry in order to preconcentrate products before spray drying. But it is used too for the production of concentrates such as sweetened concentrated milk (SCM). SCM is a widely popular product used mainly as ingredient in desserts. Brazilian people are especially fond of this product and dairy manufacturers in Brazil are then the main worldwide producers of SCM. The production is about 608 000 tons per year (Zarathencio, Van Dender, & Rego, 2017). The industrial manufacturing steps for the production of SCM are successively fat standardization of skim milk, heat treatment of standardized milk, sucrose addition, fat homogenization, concentration by vacuum evaporation up to a dry matter content equal to 700–720 g/kg, seeding and lactose crystallization, cooling and packaging (Nienwenhuijse, 2016; Renhe *et al.*, 2017). Regarding to the Regulatory Instruction No. 47, October 26, 2018 – MAPA (BRASIL, 2018), the final product must have a dairy dry matter content equal to at least 280 g/kg and a fat content

ranging from 80 to 160 g/kg. The protein content in the non-fatty dairy dry matter content must be equal to at least 340 g/kg.

In the dairy industry, concentration by vacuum evaporation is mainly carried out in falling film evaporators. This type of evaporator has a shell and tube arrangement. A thin film of liquid falls down on the internal surface of high vertical tubes whereas live steam circulates on the shell side and provides energy to the liquid for water evaporation. These evaporators are well adapted to heat sensitive products as they can work under vacuum and operate between 45 °C and 70 °C for the concentration of dairy products. Moreover, they have large heat transfer areas and short residence times. Lastly, even if evaporation is known to be a highly energy-intensive phenomenon, many efforts are made to reduce energy consumption through the reuse of the vapor coming from the product as a heating medium and the implementation of mechanical and thermal vapor recompression systems. Falling film evaporators are nowadays more energy efficient than spray-dryers in the process scheme for the manufacture of powder. Concentration in evaporators is conducted to a concentrate dry matter content as high as possible in order to

* Corresponding author.

E-mail address: italotulerperrone@gmail.com (I.T. Perrone).

<https://doi.org/10.1016/j.lwt.2021.112193>

Received 14 March 2021; Received in revised form 19 July 2021; Accepted 21 July 2021

Available online 24 July 2021

0023-6438/© 2021 Elsevier Ltd. All rights reserved.

Comparison of experimental setups for the production of milk concentrates and subsequent characterization

Érica Felipe Maurício^{a,b}, Gaëlle Tanguy^a, Cécile Le Floch-Fouéré^a, Eric Beaucher^a, Anne Dolivet^a, Antonio Fernandes de Carvalho^b, Ítalo Tuler Perrone^{c*}

^a STLO, INRAE, INSTITUT AGRO, 35042 Rennes, France

^b Federal University of Viçosa, Department of Food Technology, Avenida Peter Henry Rolfs, s/n - Campus Universitário, 36570-000, Viçosa, Minas Gerais, Brazil (ericafm90@hotmail.com)

^c Federal University of Juiz de Fora, Department of Pharmacy, Rua José Lourenço Kelmer, s/n - Campus Universitário, Bairro São Pedro, 36036-900, Juiz de Fora, Minas Gerais, Brazil

* Corresponding author. *E-mail address:* italotulerperrone@gmail.com; *Phone number:* +55 (32) 2102-3803

ABSTRACT

Vacuum concentration is an intermediary step in the dairy powder production and an essential step in the process scheme for the production of sweetened concentrated milk, a product widely popular and produced in Brazil. As any food product, it is subject to research and development in order to improve the original recipe and propose new derivatives, whether in academic or industrial environments. The tests required for the development of products may be costly in relation to the supply in raw material and cleaning agents, energy and water consumptions as well as water treatment after the cleaning of the equipment. As part of the reduction of production costs and environmental impact, the present work aims to evaluate the possibility of using smaller equipment for concentration as well as to produce relevant data on the processing of SCM. Two types of vacuum evaporators were used for this work: a pilot scale falling film evaporator and a lab scale rotary evaporator. Based on the observed results, it was possible to evidence the similarity of the data obtained for the concentrates (with and without sucrose addition) in both equipment for the measurements of density, viscosity and surface tension with deviations less than 10 %.

Keywords: Concentrate milk, sweetened concentrated milk, falling film evaporator, rotary evaporator, vacuum concentration

1. Introduction

Vacuum concentration is used mainly for the production of powders in the dairy industry in order to preconcentrate products before spray drying. But it is used too for

the production of concentrates such as sweetened concentrated milk (SCM). SCM is a widely popular product used mainly as ingredient in desserts. Brazilian people are especially fond of this product and dairy manufacturers in Brazil are then the main worldwide producers of SCM. The production is about 608 000 tons per year (Zacarchenco, Dender, Van e Rego, 2017). The industrial manufacturing steps for the production of SCM are successively fat standardization of skim milk, heat treatment of standardized milk, sucrose addition, fat homogenization, concentration by vacuum evaporation up to a dry matter content equal to 700-720 g/kg, seeding and lactose crystallization, cooling and packaging (Nieuwenhuijse, 2016; Renhe et al., 2017). Regarding to the Regulatory Instruction No. 47, October 26, 2018 – MAPA (BRASIL, 2018), the final product must have a dairy dry matter content equal to at least 280 g/kg and a fat content ranging from 80 to 160 g/kg. The protein content in the non-fatty dairy dry matter content must be equal to at least 340 g/kg.

In the dairy industry, concentration by vacuum evaporation is mainly carried out in falling film evaporators. This type of evaporator has a shell and tube arrangement. A thin film of liquid falls down on the internal surface of high vertical tubes whereas live steam circulates on the shell side and provides energy to the liquid for water evaporation. These evaporators are well adapted to heat sensitive products as they can work under vacuum and operate between 45 °C and 70 °C for the concentration of dairy products. Moreover, they have large heat transfer areas and short residence times. Lastly, even if evaporation is known to be a highly energy-intensive phenomenon, many efforts are made to reduce energy consumption through the reuse of the vapor coming from the product as a heating medium and the implementation of mechanical and thermal vapor recompression systems. Falling-film evaporators are nowadays more energy efficient than spray-dryers in the process scheme for the manufacture of powder. Concentration in evaporators is conducted to a concentrate dry matter content as high as possible in order to reduce the overall energy consumption of the process scheme, the limit of the operation being determined by the concentrate viscosity (Anema, 2009; Anema e McKenna, 1996).

Conversely, the implementation of different energy recovery systems makes tricky the configuration of evaporators and it is quite challenging to know the operating conditions applied to the product when it passes through the evaporator. In the meantime, the progressive concentration of all the components induces changes that may be irreversible, such as denaturation of proteins and mineral destabilization, into

the dairy concentrates and affects their biochemical and physical properties. As an example, concentration leads to a pH decrease, an ionic strength increase, the transfer of some calcium phosphate from the continuous phase to the dispersed phase as well as more protein instability. These biochemical changes affect the physical properties of product such as viscosity, surface tension and density. These properties influence in turn film flow through the film thickness δ (Equation 1) and the minimum wetting rate Γ_{min} of the evaporation tubes (Equation 2). Moreover, these values are required for modelling and simulation of the evaporation process (Madoumier, Azzaro-Pantel, Tanguy & Gésan-Guiziou, 2015).

$$\delta = \sqrt[3]{\frac{3 \eta \Gamma}{\rho^2 g}} \quad (\text{Equation 1})$$

where δ is the film thickness (m), η is the product viscosity (Pa.s), ρ is the density (kg/m^3), g is the gravitational constant equal to 9.81 m/s^2 and Γ the tube wetting rate of evaporation tubes ($\text{kg}/(\text{s.m})$)

$$\Gamma_{min} = 1.69 \left(\frac{\eta \rho}{g} \right)^{\frac{1}{5}} (\sigma (1 - \cos \theta))^{\frac{3}{5}} \quad (\text{Equation 2})$$

where Γ_{min} is the minimum wetting rate ($\text{kg}/(\text{m.s})$), η is the product viscosity (Pa.s), ρ is the density (kg/m^3), σ is the surface tension (N/m) and θ is the advancing contact angle of the liquid on the tube (rad). This equation was defined by Hartley & Murgatroyd (1964).

To improve the control of the concentration process and better understand the behavior of concentrates during concentration, experiments in falling-film evaporators are required. However, the configuration of these equipment and their working under vacuum makes this task tricky. It explains why there are few experimental studies on falling-film evaporators and most of them are conducted at industrial scale (Bienvenue, Jiménez-Flores, & Singh, 2003; Jeurnink, Walstra & Krutt, 1996; Jeurnink & Brinkman, 1994). Some lab and pilot scale set up were developed but they were dedicated for the study of a specific feature of the operation. Gordon et al. (2017) used of a vertical tube for studying the formation of the liquid film depending on the heat flux through the wall, the viscosity of the product and the velocity of the film. Morison and Tie (2002) studied

the behavior of proteins and minerals depending of the heat flux and the flow velocity of the product in a set up without vacuum and concentration. Kessler (1986) studied the fouling of falling-film evaporators using a pilot scale set-up made with a 2-meter high tube. Tanguy et al. (2019) also used a single effect pilot-scale falling-film evaporator for studying the behavior of acid whey during vacuum concentration. However, the carrying out of experiments at pilot scale raises the questions of the initial volume of product needed for the trials, the duration of the experiments and the consumption of cleaning solutions. For example, the trials carrying out in (Tanguy et al., 2019) to produce whey concentrate at 400 g/kg DM require at least 100 liters of liquid whey at 60 g/kg DM, last about 8 hours (including more than 3 hours for the cleaning before and after experiments). It consumes about 40 liters of both alkaline and acid cleaning solutions. But, only 2 liters of concentrated acid whey are eventually sampled for further analytical characterization. Therefore, it would be interesting to carry out experiments at lab scale in order to get samples from a lower initial volume of raw material, to reduce the duration of experiments and the quantities of cleaning solutions. The rotary evaporator is a suitable alternative to the pilot scale falling film evaporator as the working principle of both equipment are quite similar. Both are working under vacuum and the vaporization energy is provided through an indirect heat transfer between the product and the heat transfer medium (water and condensing steam in rotary and falling-film evaporators respectively). The main difference is the product does not flow in the form of a thin film in a rotary evaporator as it is held in a flask. Even if the experimental conditions are not exactly the same, it could be interesting when the outputs of the studies are to get data about the composition and the functional properties of the concentrates.

The objective of this work is to establish if the data obtained at lab scale in a rotary evaporator are representative to those obtained at pilot scale in a falling film evaporator. The comparison was made for the production of sweetened concentrate milk. Even if it is a widely consumed product, there are few data in the literature about the physical properties of this product. Moreover, the behavior during concentration is unknown, especially the evolution of density, viscosity and surface tension, some physical properties useful to characterize film flow in evaporators.

2. Materials and Methods

2.1. Experimental procedure

Concentrated milks were prepared at pilot scale in the Dairy Platform (STLO - Science and Technology of Milk and Egg research unit, Rennes, France) following the processing scheme described in Figure 1. Raw materials were cream and thermised skim milk provided by a local commercial dairy manufacturer. A standardized milk at 320 g/kg DM was prepared with 36 kg of cream and 464 kg of thermised skim milk. This mixture was heated to 40 °C using a heat exchanger (S14A, SONDEX, Saint-Genis-Laval, France) and then passed through the homogenizer (LAB 16/50, RANNIE-APV, Evreux, France) with pressure of 24 MPa (4 MPa in the 2nd stage and 20 MPa in the 1st stage). Supplementary step was added to the processing scheme related to preparation of sweetened milk that is the addition of powdered sucrose at 200 g/kg of standardized milk. The composition of both homogenized milks is given in Table 1.

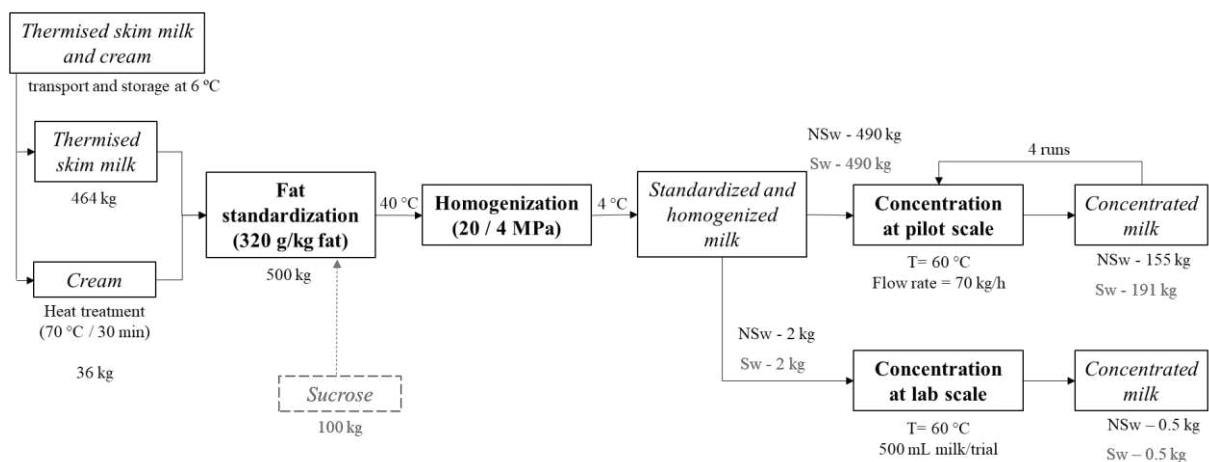

Figure 1 – Process scheme for the preparation of non-sweetened (NSw) and sweetened (Sw) milk concentrates. For the production of Sw milk concentrates, there is a supplementary step (in gray) i.e. addition of 200 g/kg of powdered sucrose to homogenized milk.

A small part of the milks was kept for further concentration at lab scale whereas most of milks was concentrated using a pilot scale falling-film evaporator (GEA Process Engineering, Montigny-Le-Bretonneux, France). This equipment is composed of three evaporation tubes in series that are connected to the same indirect condenser (coil-type heat-exchanger). It was well described and characterized by Silveira et al. (2013) and Silveira et al. (2015). The evaporation rate of the equipment is about 27 kg/h at a feed mass flowrate of 70 kg/h and a heating power of 25.2 kW.

Table 1 – Composition of non-sweetened homogenized milks AB₀ and sweetened homogenized milk CD₀.

	Non-sweetened milk AB ₀	Sweetened milk CD ₀	Analytical method described in section
pH	6.75 ± 0.02	6.74 ± 0.02	2.2.1
Sucrose (g/kg)	0	166.00	-
Dry Matter – DM (g/kg)	114.90 ± 0.10	255.99 ± 0.01	2.2.2
Dairy Dry Matter – DDM (g/kg)	114.90*	89.99*	-
Fat (g/kg)	31 ± 0	27 ± 0	2.2.3
Ash (g/kg)	6.89 ± 0.08	5.79 ± 0.04	2.2.4
TN (g/kg)	30.60 ± 0.03	26.83 ± 0.07	
NCN (g/kg)	5.46 ± 0.42	5.35 ± 0.00	2.2.5
NPN (g/kg)	1.47 ± 0.00	1.27 ± 0.00	
Calcium (mg/kg)	1176 ± 16	944 ± 1	2.2.6
Phosphate (mg/kg)	1880 ± 7	1545 ± 6	

(*)calculated: $(DM_{g/kg} = TDM_{g/kg} - Sucrose_{g/kg})$

(a)All the measurements were done in duplicate.

The experimental setup was adapted from Tanguy et al. (2016). The experiments were carried out at an absolute pressure of 0.02 MPa corresponding to an evaporation temperature of 60 °C. The products were first preheated from 20 °C to 60 °C using a tubular heat-exchanger and they were concentrated by passing through the pilot scale falling-film evaporator at a mass feed flowrate of 70 kg/h. Several successive runs were carried out to produce milk concentrates at increasing concentration factors (Figure 2). The concentration factor is the ratio of the dry matter content of the concentrate at the outlet of the evaporator over the dry matter content of the homogenized milk. Evaporation temperature and feed mass flowrate were kept constant whatever the run whereas the heating power was adjusted to modify the evaporation rate and produce concentrates at specific dry matter contents.

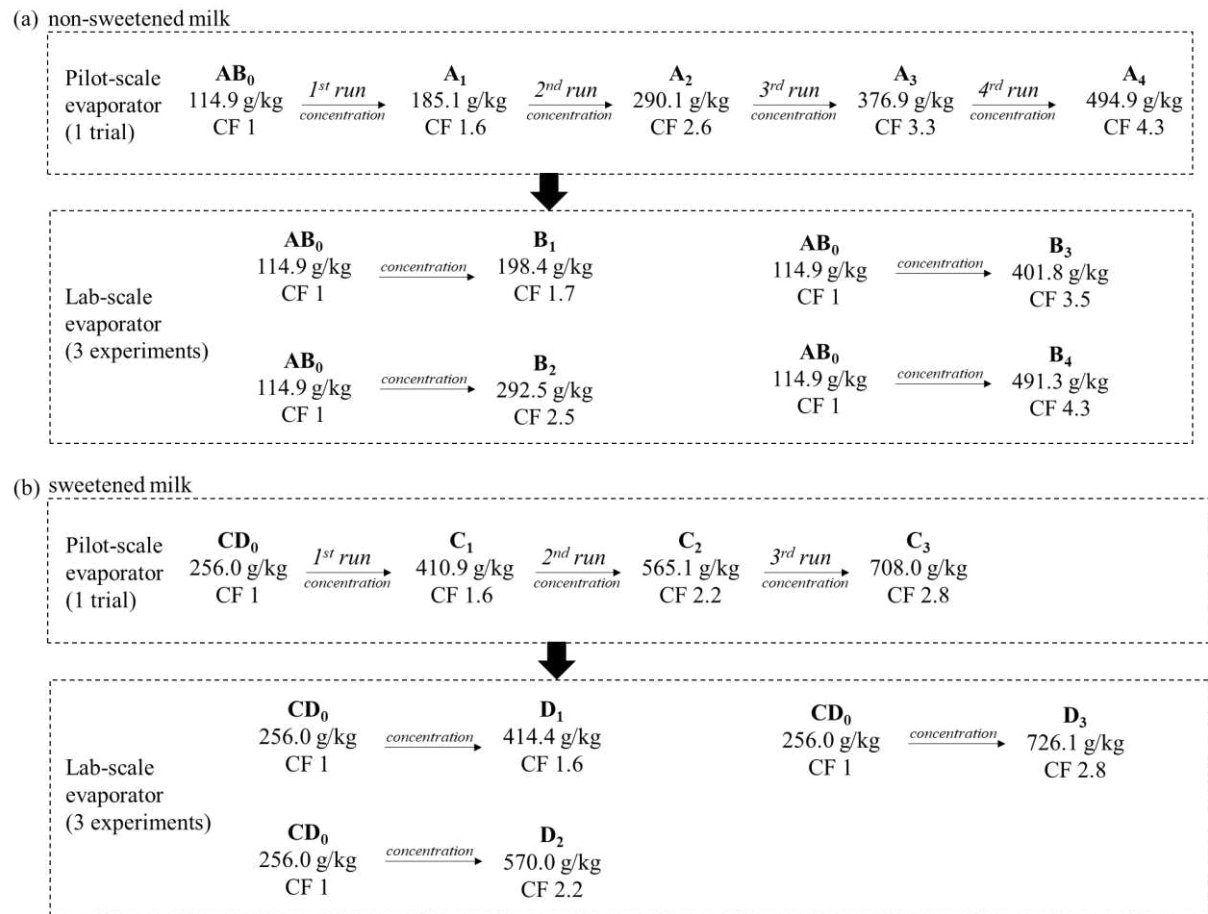

Figure 2 – Experimental procedure for the production of (a) non-sweetened milk concentrates and (b) sweetened milk concentrates at different DM contents using the pilot scale evaporator and the lab scale evaporator. The same milk was used for experiments at pilot scale and lab scale i.e. non-sweetened milk AB_0 (resp. sweetened milk CD_0) for the preparation of the non-sweetened milk concentrates (resp. sweetened milk concentrates). In both cases, the maximal DM contents was defined with respect to the maximal DM content achievable in industrial evaporators. The DM contents of the concentrates produced at lab-scale were defined in function of the DM contents of the concentrates produced at pilot-scale. DM = dry matter and CF = concentration factor.

The concentrates were prepared at lab-scale using a rotary evaporator (Hei-VAP Value Digital, Heidolph Instruments, Schwabach, Germany) at the same absolute pressure and evaporation temperature used in the pilot (i.e. 0.02 MPa and 60 °C respectively). The rotation speed of the 1-liter flask was 80 rpm. For each concentrate,

the starting material was always 500 ml of homogenized milk and the vacuum concentration was conducted up to the DM content reached at pilot-scale.

The DM content for the non-sweetened (AB₀) and sweetened (CD₀) milks were 114.9 and 256.0 g/kg. The method used for the determination of DM content is described in section 2.2.2. To reach the maximum DM of non-sweetened and sweetened concentrates usually achieved in industrial evaporators, it was necessary to carry out 4 and 3 runs in the pilot scale evaporator respectively. Four concentrates were produced from non-sweetened milk. The DM contents of the final concentrates produced at pilot scale and lab scale, A₄ and B₄ respectively, were 494.9 ± 0.1 and 491.3 ± 0.1 g/kg. Three concentrates were produced from sweetened milk. The DM contents of the final concentrates produced at pilot scale and lab scale, C₃ and D₃ respectively, were 708.0 ± 0.1 and 726.1 ± 0.1 g/kg (Figure 2).

2.2. Physico-chemical characterization

In order to perform easily analysis and avoid age-thickening of more concentrated products, concentrates were diluted to the DM content of the corresponding homogenized milk for the determination of the following parameters: dry matter, nitrogen, ash and total ion contents.

The experimental values obtained for a biochemical parameter (nitrogen, ash and total ion contents) of a concentrate were compared to the theoretical value. It corresponds to the product of the experimental value in homogenized milk by the concentration factor.

2.2.1. pH measurement

The pH values of homogenized milks and concentrates were determined using a pH meter (HI 9024 microcomputer pH meter, Hanna Instruments, Lingolsheim, France) with a pH electrode (HI 1230B, Hanna Instruments, Lingolsheim, France).

2.2.2. Dry matter content

The DM contents were determined as described by IDF standard 21B (ISO-IDF, 1987). Five grams of each homogenized milk and re-diluted concentrate were mixed with sand in a capsule and were dried at 102 ± 2 °C in an oven for a period of 7 hours. The weight loss of the capsule after drying was taken as the amount of water evaporated during vacuum concentration.

2.2.3. Fat content

The fat content of homogenized milks was determined using acid butyrometric method (FIL-IDF, 1997)

2.2.4. Ash content

The ash contents were determined by incineration of 10 grams of each homogenized milk and re-diluted concentrate at 550 °C for 5 h and weight of the residue obtained (ISO-IDF, 1964).

2.2.5. Nitrogen contents

Total nitrogen (TN) contents of each homogenized milk and re-diluted concentrate were determined using the Kjeldahl method as described by IDF standard 20B (ISO-IDF, 1993). A factor of 6.38 was applied to convert nitrogen into milk protein content.

2.2.6. Ion contents

The mineral composition of homogenized milks and concentrates was determined using ion exchange chromatography (IEC-Dionex-500, Jouy-en-Josas, France) (Gaucheron, Le Graet, Piot, & Boyaval, 1996) for anions and atomic absorption spectrometry (AAS-220FS, Varian, Les Ulis, France) for cations (FIL-IDF, 1992). The experimental errors of both methods are $\pm 0.5\%$ and $\pm 2.3\%$, respectively. The studied anions were inorganic phosphate, chloride and citrate and the studied cations were calcium, sodium, potassium and magnesium.

Total and soluble ion contents of milks and concentrates were determined according to Tanguy et al. (2019). The recovery of the soluble phase was carried out according to a 2-step procedure: (1) ultracentrifugation of milks and concentrates for 1 h at 100,000 g and 40 °C in order to favor sedimentation of proteins (mainly caseins), (2) ultrafiltration of supernatant using analytical membrane (molecular weight cut-off of 10 kDa, Vivaspin, Palaiseau, France) and centrifugation for 1 h at 1800 g and at room temperature. This analytical procedure was performed in the same day that the concentration trials.

2.2.7. Viscosity measurement

The viscosity of concentrates was measured using a rotational viscometer type coaxial cylinder (RM 100 Plus, Lamy Rheology, Champagne-au-Mont-d'Or, France). Measurements were made at a controlled temperature of 60.0 ± 0.5 °C and at shear rates ranging from 100 to 500 s^{-1} . The experimental error was $\pm 0.32 \text{ mPa}\cdot\text{s}$. After data collection, it is possible to make a graph and draw the trend line for each type of evaporator used (pilot and lab scale) and from them to predict the viscosity value in a certain desired dry matter value.

2.2.8. Density measurement

The density of milks and concentrates was measured using an oscillating density meter (DM48, Anton-Paar, Les Ulis, France) at a controlled temperature of 60.0 °C. The experimental error was $\pm 0.1 \text{ kg/m}^3$. After data collection, it is possible to make a graph and draw the trend line for each type of evaporator used (pilot and lab scale) and from them to predict the density value in a certain desired dry matter value.

2.2.9. Surface tension measurement

The surface tension of milks and concentrates was measured at 60 °C using a pendant drop tensiometer ('Tracker', Teclis-Scientific, Civrieux-d'Azergues, France). To evaluate the impact of gravity on droplet shape, the Bond number Bo (Equation 3) was calculated for all the samples.

$$Bo = \frac{\rho g R^2}{\gamma} \quad (\text{Equation 3})$$

where ρ is the droplet density (kg/m^3), g the acceleration of gravity (m/s^2), R the radius of the droplet (m) and γ stands for the droplet surface tension (N/m).

Drops with $8 \mu\text{L}$ and Bond number between 0.2 and 0.3 were formed at the tip of a syringe containing the samples and the measurements were made immediately after their formation. The drop profile was determined by image analysis using WDROP Software ('Tracker', Teclis-Scientific, Civrieux-d'Azergues, France) from which the surface tension was derived. Under mechanical equilibrium of capillary and gravity forces, the Laplace equation relates the pressure difference across the interface (liquid-air), the surface tension and the surface curvature. After data collection, it is possible to make a graph and draw the trend line for each type of evaporator (pilot and

lab scale) used and from them to predict the surface tension value in a certain desired dry matter value.

2.2.10. Statistical analysis

The concentrations were done once and generated 4 products with different concentration factors and analyzes made with each concentrate were performed in duplicate. The statistical analysis was done using R software version 3.5.3 (R Foundation for Statistical Computing, Vienna, Austria). With the results of density, viscosity and surface tension for the concentrates obtained in the rotary evaporator and in the pilot falling film evaporator an ANOVA was performed. If the F value indicated a difference between the means, the normality and homogeneity of the data was analyzed using the Shapiro-Wilk and Bartlett tests, respectively, and both tests at 5 % significance. Finally, Tukey's analysis was used to identify group differences. Significance was defined as a P value < 0.05.

3. Results and Discussion

3.1. Dry matter of concentrate

Four non-sweetened concentrates (A₁ to A₄) were prepared at pilot scale with DM contents ranging between 185.1 and 494.9 g/kg (Figure 2). The DM content of the final concentrate A₄ is in the range of the maximum achievable values that can be obtained at the outlet of the industrial falling film evaporators for such a product (Schuck, Dolivet & Jeantet, 2012).

The addition of powdered sucrose leads to an increase of the DM content of homogenized milk from 114.9 to 256.0 g/kg (AB₀ and CD₀ respectively). Three concentrates (C₁ to C₃) were prepared at pilot scale at 410.9, 565.1 and 708.0 g/kg (Figure 2). The DM content of the final concentrate C₃ is the same that the one of a commercial product (BRASIL, 2018; Renhe et al., 2017).

The non-sweetened and sweetened concentrates have a variance less ≤ 1.8 when compared to the lab and pilot scales (Figure 2).

3.2. Behavior of non-sweetened and sweetened concentrates during concentration

3.2.1. pH

Sucrose addition does not change the pH of homogenized milks (6.75 and 6.74, for AB₀ and CD₀ respectively). Then the pH of concentrates decreases during

concentration in both cases probably due to (i) the increase in ionic strength that affects the activity coefficients and the pKa values of the protonated species, (ii) the transfer of some calcium and phosphate ions from the colloidal to the soluble phase, (iii) and the precipitation of calcium phosphate (Anema, 2009).

The pH variation between the non-sweetened milk AB₀ and the concentrate A₄ is 0.53 ± 0.01 . Likewise, it is equal to 0.55 between the sweetened milk CD₀ and the concentrate C₃. However, the pH decreases at a given concentration factor is sharper for the sweetened concentrates than for the non-sweetened concentrates (Figure 3a). For example, at a concentration factor of 2.2, the pH of the sweetened concentrate is 6.31 whereas it is about 6.53 for the non-sweetened concentrate. This sharper decrease in pH in the sweetened concentrates may be due to the addition of sucrose to milk that induces a decrease in water activity and promotes the Maillard reaction. Indeed, the Maillard reaction is strongly favored when the water activity decreases from 1 to 0.6-0.7. Even if the Maillard reaction is not intensified during vacuum concentration, the first steps of this complex reaction may occur, leading to the formation of formic acid and acetic acid which tends to lower the pH (Martins, Jongen e Boekel, van, 2001).

3.2.2. Total nitrogen and ash contents

The total nitrogen and ash contents are equal to 30.60 and 6.89 g/kg in non-sweetened milk whereas they are equal to 26.83 and 5.79 g/kg in sweetened milk. These lower nitrogen and ash contents in sweetened milk are related to a dilution effect induced by the addition of powdered sucrose.

As shown on Figures 3b and 3c, total nitrogen and ash contents increase linearly with increasing concentration factors. It indicated that there are no losses of both compounds in the equipment.

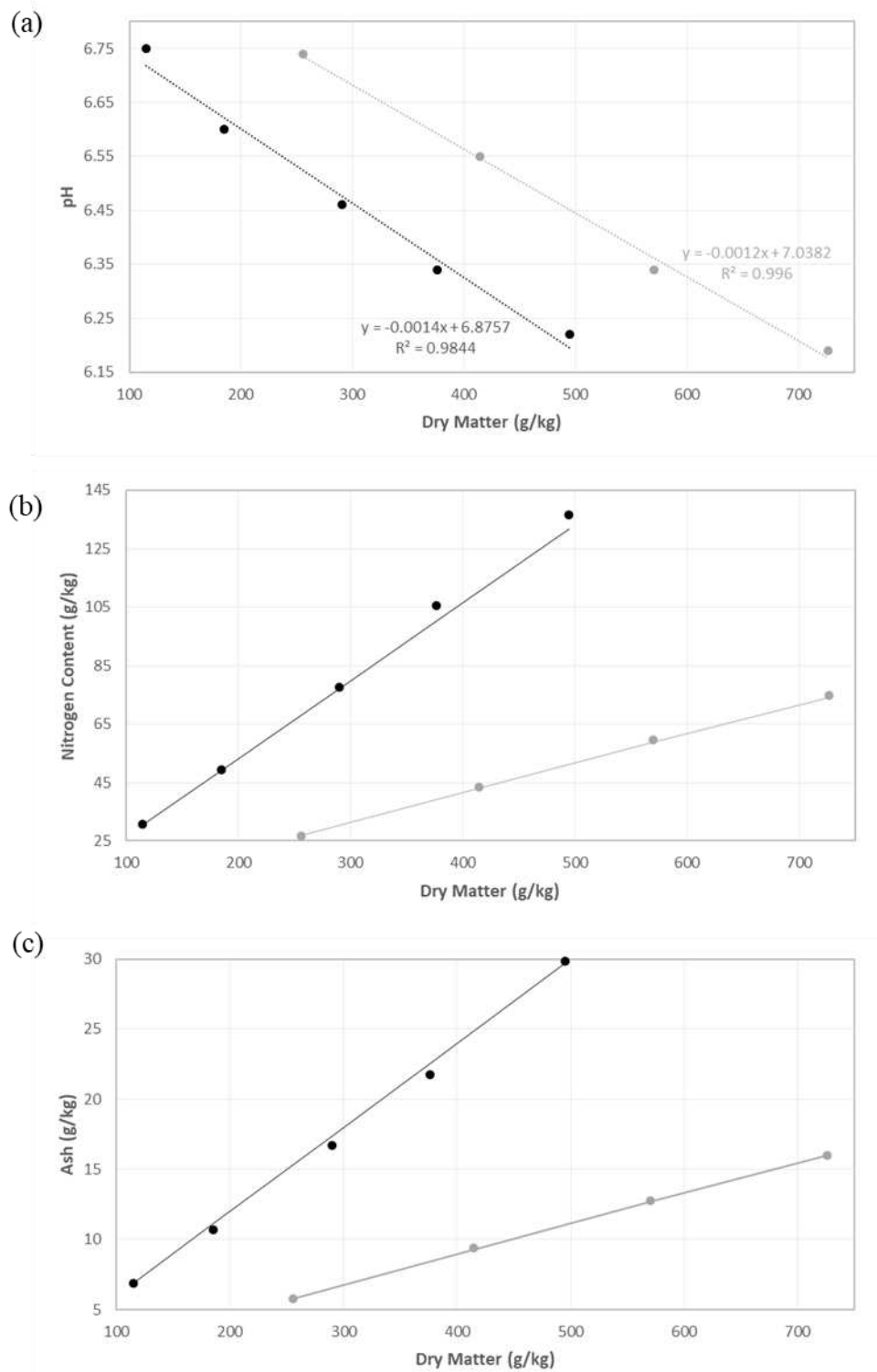

Figure 3 – Evolution of (a) pH, (b) total nitrogen and (c) ash contents of concentrates during concentration of non-sweetened (NSw) and sweetened (Sw) homogenized milks at pilot scale. Legend: Experimental data (•) NSw and (•) Sw; Theoretical data (—) NSw and (—) Sw; Tendency lines (—) NSw and (—) Sw.

3.2.3. Minerals

Concerning the mineral composition of products, Figure 4 highlights the experimental values of total calcium, phosphate, citrate and magnesium in the non-sweetened and sweetened concentrates are similar to the theoretical values, leading to the belief that there were no losses of these ions during the concentration process, more especially no ion deposit on the surface of evaporation tubes during concentration. Based on the visual analysis of the tubes and, mainly, on the analysis of minerals and proteins made in milks before concentration and throughout the concentration in the concentrated products. In the meantime, it is possible to observe that there is a difference between total and soluble ion contents and it increased with concentration. This difference corresponds in one hand to the ions into the colloidal phase that were mainly removed with caseins during the ultracentrifugation step, and in the other hand to the insoluble salts that may have precipitated in the concentrate during concentration. This latter part of insoluble ions was mainly removed during the analytical ultrafiltration and centrifugation steps. The difference between the total and soluble ion contents are all the more important with increasing concentration that there is a transfer of some salts from the soluble to the colloidal phase due to concentration.

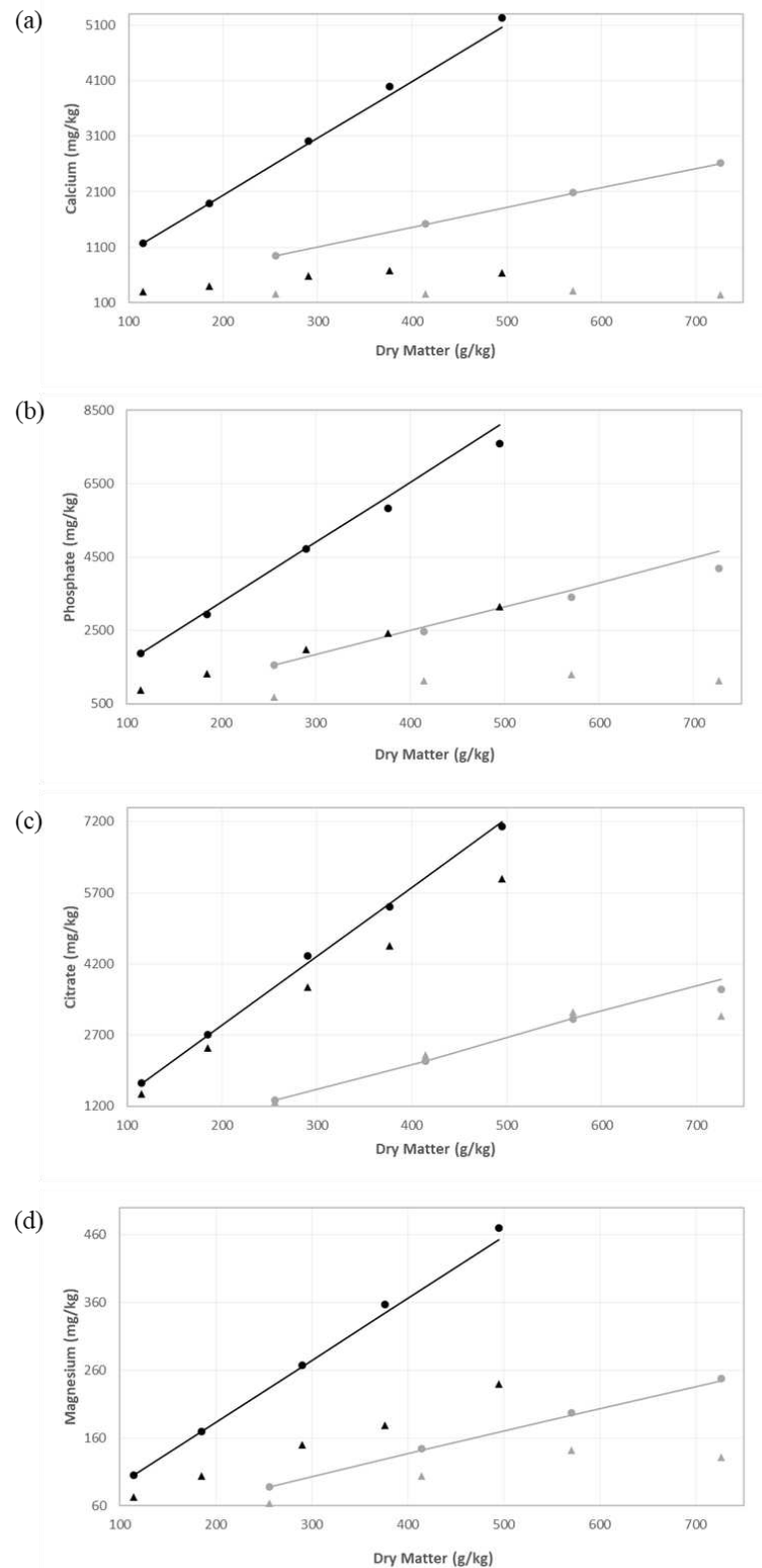

Figure 4 – Evolution of total and soluble ion contents during concentration of non-sweetened (NSw) and sweetened (Sw) homogenized milks: (a) calcium, (b) phosphate, (c) citrate and (d) magnesium. Legend: Theoretical Total (•) NSw and (•) Sw; Experimental Total (▲) NSw and (▲) Sw; Soluble Experimental (—) NSw and (---) Sw.

3.2.4. Physical properties

Figure 5 shows the evolution of some physical properties (density, viscosity and surface tension) of the concentrates throughout the concentration. In all cases, the experimental variance is plotted, but it is too small to see on graphics.

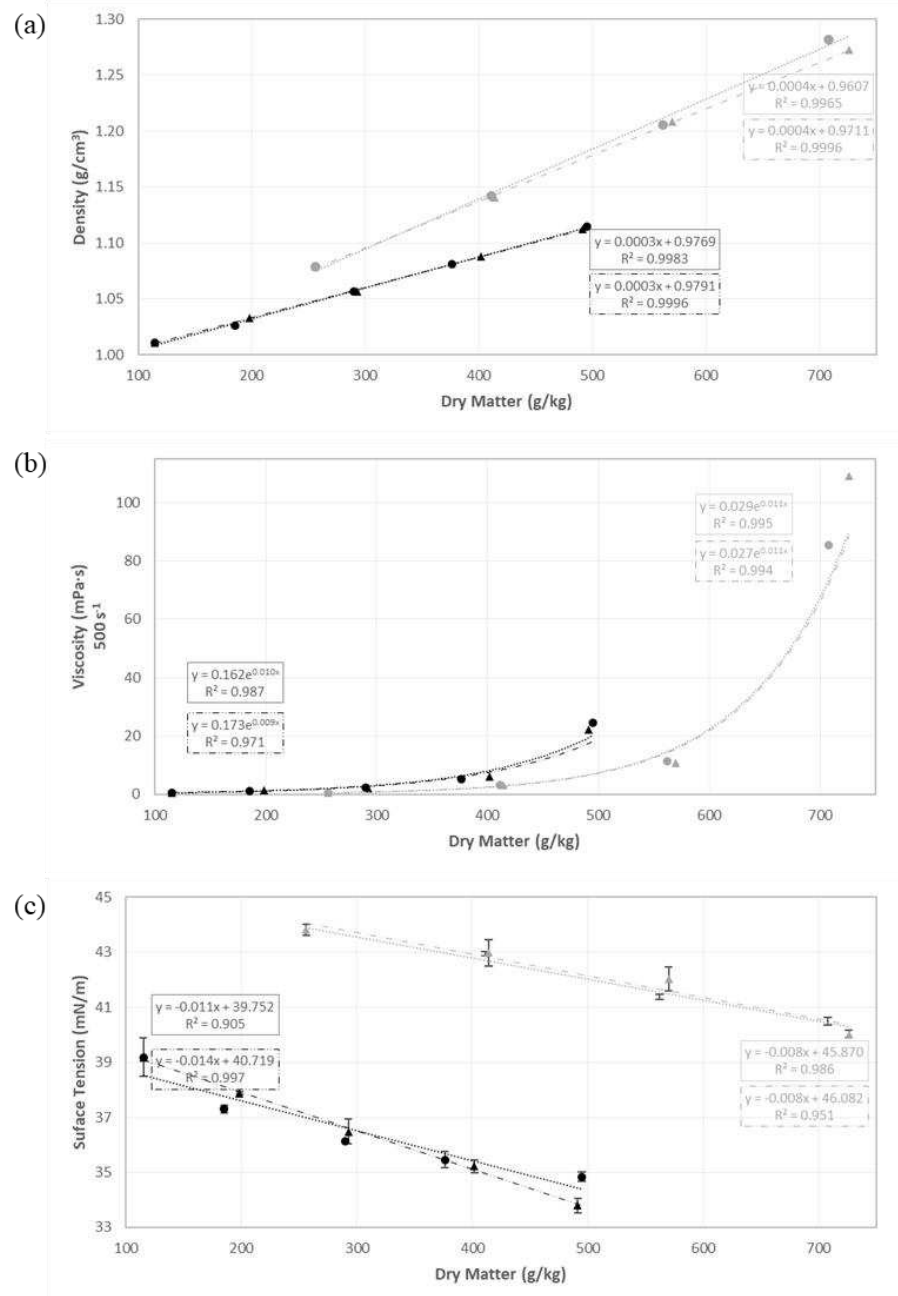

Figure 5 – Evolution of some physical properties of non-sweetened (black) and sweetened (gray) milk concentrates during concentration using a pilot scale evaporator (○) and a lab-scale evaporator (Δ): (a) density, (b) viscosity and (c) and surface tension.

Legend: ● Pilot scale - NSw ▲ Lab scale - NSw ● Pilot scale - Sw ▲ Lab scale - Sw

3.2.4.1. Density

The addition of 200 g/kg of powdered sucrose to milk induces an increase of milk density from 1.0111 ± 0.0002 for AB₀ to 1.0785 ± 0.0001 g/cm³ for CD₀³. The density increases linearly with the concentration factor for both types of products. Density of non-sweetened products increases from 1.0111 ± 0.0002 g/cm³ for AB₀ to 1.1137 ± 0.0014 g/cm³ for A₄ and B₄ (average between the two concentrates). In the meantime, density increases from 1.0785 ± 0.000 g/cm³ for CD₀ to 1.28 ± 0.0001 g/cm³ for C₃ and D₃ (average between the two concentrates).

3.2.4.2. Viscosity

The addition of 200 g/kg of powdered sucrose to milk leads to an increase of milk viscosity. Milk viscosity measured at 60°C and 500 s⁻¹ increases from 1.33 ± 0.14 mPa.s for AB₀ to 3.02 ± 0.02 mPa.s for CD₀. This is due to the addition of supplementary dry matter to milk.

Viscosity increases exponentially with concentration. It is all the faster than the dry matter of homogenized milk is high. The viscosity of non-sweetened products increases from 1.33 ± 0.14 mPa.s for AB₀ to 23.4 ± 1.24 for A₄ and B₄ (average between the two concentrates) whereas the viscosity of sweetened products increases from 3.02 mPa.s for CD₀ to 100 mPa.s for C₃ and D₃ (average between the two concentrates).

3.2.4.3. Surface tension

The addition of 200 g/kg of sucrose to milk induces an increase in surface tension from 39.19 ± 0.69 mN.m⁻¹ for AB₀ to 43.82 ± 0.20 N.m⁻¹ for CD₀. According to the literature, sucrose (co-solvent) has a strong bond with water and this type of co-solvent does not bind directly to the surface of the protein, leaving a space that is filled with water making the protein hydrated, thus, this type of co-solvent is said to be preferentially excluded. This hydration protects globular proteins and mainly favors the native form of the protein, leaving it in its globular shape (Baier e McClements, 2003; Desu e Narishetty, 2013; McClements, 2002; Timasheff, 1993). The increase in surface tension observed in the analysis may occur due to three factors when adding sucrose: (i) the increase in viscosity that increases the stability of the product (Docoslis, Giese e Oss, van, 2000), (ii) the decrease in lipid-protein interactions at the

interface (concentrate-air), because the protein is folded, leaving fewer groups exposed, like sulfhydryl groups, for interaction, with that the two constituents are on the surface, but in their separate forms (Wilde et al., 1997) and (iii) the protein is preferably adsorbed at the interface (concentrate-air) (Wouters et al., 2017).

The surface tension of both products at 60 °C has the same behavior during concentration that is a decrease with concentration. The concentration of non-sweetened milk from AB₀ to A₄ and B₄ (average between the two concentrates) reduces the surface tension from 39.19 ± 0.69 to 34.32 ± 0.73 mN/m. In the meantime, the surface tension of sweetened products decreases from 43.82 ± 0.20 for CD₀ to 40.26 ± 0.33 mN/m for C₃ and D₃ (average between the two concentrates). Since proteins, fat and free fatty acids are the main surfactants found in milk, there is an increase in these constituents on the surface of the drop along the concentration, leading to the observed decrease (Williams et al., 2005). With the dilution effect caused by sucrose addition to milk, there is also the dilution of these surfactants, thus leading to less variation in surface tension between non-sweetened and sweetened products.

3.2.5. Comparison of results at lab-scale and pilot-scale

As shown on Figure 5, the trend curves of the physical properties of concentrates obtained at pilot and lab-scale are superimposed. However, some small deviations can be observed for properties that are sensitive to the variation of dry matter content, such as viscosity. In this case the variation of 18.2 g/kg DM between sweetened concentrates at pilot and lab scale (C₃ and D₃ respectively) showed a variance of 16.84 mPa·s.

Statistical analysis of data from the following groups: surface tension, density and viscosity detected through the F value of the ANOVA that there is some kind of significant difference within the data of each group at 5 % significance. In order to identify what the differences would be, the Tukey test was carried out at 5 % significance, which indicated that the differences were found at each concentration point and not between the samples of the two types of evaporators used. That is, when increasing the concentration of total solids, these concentrates had their properties significantly changed, but for the same concentration level in different equipment, a statistically significant difference was not detected. When modifying the concentration equipment there is no change in the product obtained at the same concentration level. Except, for the sweetened concentrates D₃ and C₃ (produced at lab scale and pilot

scale respectively), which did not have similar averages for DM content (708.0 ± 0.0 and 726.1 ± 0.0 g/kg DM) and as a consequence, they have different viscosity values. But, when applying the trend line equations to 700 g/kg DM for example, similar viscosity values are obtained: 63.9 ± 0.2 and 68.7 ± 0.1 mPa·s for concentrates prepared at lab-scale and pilot-scale respectively.

Density is a property highly dependent on the dry matter content and a variation of 18.2 g/kg in DM content between the sweetened concentrates produced at lab-scale and pilot-scale leads to a statistical differentiation between both concentrates. However, as for viscosity values, when comparing the results determined at a same DM content and using the trend lines, similar density values are obtained for concentrates produced at lab-scale and pilot-scale.

These results showed that the values of density, viscosity and surface tension of concentrates produced at lab-scale are representative of values obtained for concentrates produced at pilot-scale. It is possible to change the falling film evaporator to the rotary evaporator in order to provide data on the physical properties of the concentrates.

3.2.6. Economic analysis

As both equipment used for this study allow producing concentrates at equivalent physical properties, it is interesting to evaluate the economic and environmental benefits of using smaller equipment.

The main difference between the rotavapor and the falling-film evaporator is the size of the equipment and their resulting evaporation rate, 0.5 kg/h of evaporated water and 27 kg/h respectively. It implies that the quantities of standardized milk required for carrying out experiments are greatly different. As shown in Table 2, when using the falling-film evaporator for the production of non-sweetened concentrate, at least 100 kg of standardized milk at 120 g/kg DM are necessary, which results in the production of about 24 kg of concentrate at 500 g/kg DM. If the objective of the trial is to recover some concentrate for further characterization such as biochemical composition and physical properties, a large part of the concentrate produced is thrown into drains and it generates unnecessary wastes.

Table 2 – Comparison of the carrying out of experiments in a falling-film evaporator and a rotavapor – Application to the concentration of non-sweetened milk at 120 g/kg DM for the production of milk concentrate at 500 g/kg DM

Parameters	Pilot scale <i>Falling-film evaporator</i>	Lab scale <i>Rotavapor</i>
Initial quantity of milk at 120 g/kg DM (kg)	100	2
Maximal evaporation rate of the equipment (kg/h)	27	0.5
Quantity of concentrate at 500 g/kg DM (kg)	24	0.5
Quantity of evaporated water (kg)	76	1.5
Duration of the concentration step (h)	4	2.8
Total duration of use of the equipment ⁽¹⁾ (h)	6.8	3
Cleaning agents used	acid and alkaline solutions	Bio detergent
Volume of cleaning agents	40.44 L (alkaline solution) 40.16 L (acid solution)	~10 mL
Total water consumption ⁽¹⁾ (L)	2600	2.0 + 8.0 ⁽²⁾
Total energy consumption ⁽¹⁾ (kWh)	204.3	9.1

⁽¹⁾ including the concentration and the cleaning steps

⁽²⁾ Reusable and/or recirculating water.

We estimated that for our studies, a quantity of about 0.5 kg is enough to carry out microbiological and physicochemical analysis on the concentrated products. The physicochemical analysis included the measurement of viscosity, density, surface tension as well as the determination of the biochemical composition of the concentrates. Some samples can also be used to prepare the subsequent drying step in the production process of dairy powders using for example the desorption method (Schuck et al., 1998; Schuck et al., 2009). This method allows to analyze the final product's moisture and water activity. Another possibility is to spray dry the concentrate obtained at lab scale in a small spray-dryer similar to the one used by Maury et al.

(2005). From the combination of both equipment at lab-scale, it is possible to predict the behavior of the product during drying and identify the more relevant operating parameters for the drying stage at pilot and/or industrial scale. In addition, for both products, microbiological tests can be performed, to determine for example the growth rate and growth conditions of microorganisms and evaluate the evolution of the product during storage and their shelf life.

Another drawback when using the pilot scale falling-film evaporator to produce samples for product characterization is the use of larger volumes of cleaning agents. Nitric acid and sodium hydroxide solutions are generally used for the cleaning of evaporators (Goode, Asteriadou, Robbins & Fryer, 2013; Hagsten et al., 2016; Jeurnink & Brinkman, 1994). For our trials, we used about 20 liters of alkaline solution (20 mL/L) and 20 liters of acid solution (10 mL/L) to clean the equipment before experiment and again 20 liters of alkaline solution (20 mL/L) and 20 liters of acid solution (10 mL/L) after experiment. In comparison, the lab scale rotary evaporator requires only ~10 milliliters of biodegradable detergent. As a consequence, it reduces drastically the impact on the environment (Table 2).

The use of a rotary evaporator allows also reducing the experiment time. Considering only the concentration step of the product, the equipment use time do not differ too much, respectively 4.0 and 2.8 hours for the rotary and the falling-film evaporators. However, if we consider the total duration of use of the equipment, the falling film evaporator is greatly longer than the one of the rotary evaporator. Indeed, the cleaning steps before and after concentration, the stabilization of operating parameters before concentration and the cooling of the equipment after concentration extend the duration of use of the equipment. A complete cleaning step lasts about 2 hours, the stabilization of the operating parameters and the cooling about 30 minutes each (Table 2). At lab scale, these procedures are shorter (cleaning step and stabilization of operating parameters) or are not applied (no cooling of the equipment after concentration).

The energy consumption was calculated taking into account the electric power of each pump (manufacturer's manual data) of the equipment and their time use. Thus, for the pilot scale falling-film evaporator, 4 product pumps (0.75 kW each), 1 condensate pump (0.75 kW), 1 vacuum pump (1.1 kW) and 3 boilers (8.4 kW each) were used during 6.8 hours, resulting in an electrical consumption equal to 204.3 kWh. For the rotavapor, 1 cooler (0.14 kW), 1 rotavapor (1.4 kW), 1 thermostatic bath (1.3

kW) and 1 vacuum pump (0.18 kW) were used during 3 h, resulting in a consumption of 9.1 kWh (Table 2). The pilot scale thus shows a saving of 95.5 % in energy consumption. The analysis of energy consumption within the production of dairy products is very relevant, since evaporation alone consumes 12 % of electrical energy and 39 % of thermal energy for the manufacture of powdered milk (Finnegan et al., 2017). Therefore, it is extremely important when using an alternative equipment to do a test screening.

Longer duration uses of equipment, higher volumes of product and cleaning agents for the experiments at pilot scale impact greatly on the water and energy consumptions. We estimated that a trial on the falling film evaporator consumes about 2,600 liters (Table 2). It should be noted that about 92 % of this volume is used at the condenser to ensure the production of vacuum inside the evaporator. The facility is not equipped with recovery systems and the installation of a closed-loop cooling system would reduce drastically water consumption. At lab scale, only an 8-liter thermostatic bath and a cooler with recirculating water are used. Therefore, the water effectively consumed by this equipment is used to clean the evaporation flasks (approximately 2 L). Obviously, when using a recirculation method for the condenser water, this consumption value would be reduced and the impact would already be less in relation to the amount of water discharged. However, in the other parameters analyzed throughout the work, this would not influence when having equipment with similar characteristics such as evaporative capacity and flow.

4. Conclusions

In the process scheme for the production of sweetened concentrated milk, it is known the addition of 200 g/kg of powdered sucrose to milk alters greatly the physico-chemical properties of milk and the resulting concentrates produced using vacuum concentration in falling-film evaporators. As an example, the maximum achievable dry matter content at the outlet of the evaporator is 500 and 720 g/kg for non-sweetened milk concentrates and sweetened milk concentrates. The experimental results of this study provided more data on the physical properties of sweetened milk concentrates.

The non-sweetened and sweetened concentrates were prepared in parallel in a lab-scale rotary evaporator and in a pilot scale falling-film evaporator. They were characterized in particular in term of density, viscosity and surface tension. For these parameters, low variance was observed between the products obtained in both

concentration equipment. Furthermore, the sensitivity of the viscosity and density parameters to a low variation in total solids between the last sweetened concentrate of both concentration equipment was reaffirmed. It makes then possible to change the concentration step for the production of sweetened and non-sweetened milk concentrates from pilot to lab scale by using a rotary evaporator. It allows to reduce the duration of trials, the volume of raw material, to save energy and water and preserve environment. However, the change can be used when the aims of the trials are to get samples for further characterization and when the volume required is low.

Declaration of competing interest

We have no conflict of interest to declare.

Acknowledgment

Capes and CNPq for the financial support and to Arnaud Saint-Jalmes for kindly giving up the laboratory at Rennes Institute of Physics for the analysis of surface tension.

References

- ANEMA, S. G. Effect of milk solids concentration on the pH, soluble calcium and soluble phosphate levels of milk during heating. *Dairy Sci. Technol.*, v. 89, n. 89, p. 501–510, 2009.
- ANEMA, S. G.; MCKENNA, A. B. Reaction kinetics of thermal denaturation of whey proteins in heated reconstituted whole milk. *Journal of Agricultural and Food Chemistry*, v. 44, n. 2, p. 422–428, 1996.
- BAIER, S. K.; MCCLEMENTS, D. J. Combined Influence of NaCl and Sucrose on Heat-Induced Gelation of Bovine Serum Albumin. *Journal of Agricultural and Food Chemistry*, v. 51, n. 27, p. 8107–8112, 2003.
- BIENVENUE, A.; JIMÉNEZ-FLORES, R.; SINGH, H. Rheological Properties of Concentrated Skim Milk: Influence of Heat Treatment and Genetic Variants on the Changes in Viscosity during Storage. *Journal of Agricultural and Food Chemistry*, v. 51, n. 22, p. 6488–6494, 2003.
- BRASIL. Normative Instruction No. 47, of October 26, 2018 - Ministry of Agriculture, Livestock and Supply. *Diário Oficial da União*. [s.l: s.n.].

- CARVALHO, A. F. DE; NEVES, B. DOS S.; PERRONE, Í. T.; STEPHANI, R.; VIEIRA, S. D. Á. Leites concentrados e desidratados. Juiz de Fora: Templo Gráfica e Editora Ltda., 2013.
- DESU, H. R.; NARISHETTY, S. T. Challenges in Freeze–Thaw Processing of Bulk Protein Solutions. In: Sterile Product Development. [s.l.] Springer, New York, NY, 2013. p. 167–203.
- DOCOSLIS, A.; GIESE, R. F.; OSS, C. . J. VAN. Influence of the water – air interface on the apparent surface tension of aqueous solutions of hydrophilic solutes. *Colloids and Surfaces B: Biointerfaces*, v. 19, p. 147–162, 2000.
- FIL-IDF. International Dairy Federation 154:1992. Milk and powdered milk - Determination of calcium content. Flame atomic absorption spectrometric method. [s.l: s.n.].
- FINNEGAN, W.; GOGGINS, J.; CLIFFORD, E.; ZHAN, X. Environmental impacts of milk powder and butter manufactured in the Republic of Ireland. *Science of the Total Environment*, v. 579, p. 159–168, 2017.
- GAUCHERON, F.; GRAET, Y. LE; PIOT, M.; BOYAVAL, E. Determination of anions of milk by ion chromatography. *Lait*, v. 76, n. 5, p. 433–443, 1996.
- GOODE, K. R.; ASTERIADOU, K.; ROBBINS, P. T.; FRYER, P. J. Fouling and cleaning studies in the food and beverage industry classified by cleaning type. *Comprehensive Reviews in Food Science and Food Safety*, v. 12, n. 2, p. 121–143, 2013.
- GORDON, D.; BOLISSETTI, T.; TING, D. S. K.; REITSMA, S. Short-term fluid temperature variations in either a coaxial or U-tube borehole heat exchanger. *Geothermics*, v. 67, p. 29–39, 2017.
- HAGSTEN, C.; ALTSKÄR, A.; GUSTAFSSON, S.; LORÉN, N.; HAMBERG, L.; INNINGS, F.; PAULSSON, M.; NYLANDER, T. Composition and structure of high temperature dairy fouling. *Food Structure*, v. 7, p. 13–20, 2016.
- HARTLEY, D. E.; MURGATROYD, W. Criteria for the break-up of thin liquid layers flowing isothermally over solid surfaces. *International Journal of Heat and Mass Transfer*, v. 7, p. 1003–1015, 1964.
- ISO-IDF. International Standard 27 - Determination of the ash content of processed cheese product Brussels, Belgium: International Dairy Federation. [s.l: s.n.].
- ISO-IDF. International Standard 21B - Milk, cream and evaporated milk: Determination of total solids content Brussels, Belgium: International Dairy Federation. [s.l: s.n.].

- ISO-IDF. International Standard 20B - Milk: determination of nitrogen content Brussels, Belgium: International Dairy Federation. [s.l: s.n.].
- JEURNINK, T. J. M.; BRINKMAN, D. W. The cleaning of heat exchangers and evaporators after processing milk or whey. *International Dairy Journal*, v. 4, n. 4, p. 347–368, 1994.
- JEURNINK, T. J. M.; WALSTRA, P.; KRUTT, C. G. DE. Mechanisms of fouling in dairy processing. *Netherlands Milk & Dairy Journal*, v. 50, p. 407–426, 1996.
- KESSLER, H. G. Multistage evaporation and water vapour recompression with special emphasis on high dry matter content, product losses, cleaning and energy savings. *Milk – the Vital Force, 22nd international dairy congress. Anais...Dordrecht: The Hague: Reidel Publishing Co., 1986*
- MADOUMIER, M.; AZZARO-PANTEL, C.; TANGUY, G.; GÉSAN-GUIZIOU, G. Modelling the properties of liquid foods for use of process flowsheeting simulators: Application to milk concentration. *Journal of Food Engineering*, v. 164, p. 70–89, 2015.
- MARTINS, S. I. F. S.; JONGEN, W. M. F.; BOEKEL, M. A. J. S. VAN. A review of Maillard reaction in food and implications to kinetic modelling. *Trends in Food Science and Technology*, v. 11, p. 364–373, 2001.
- MAURY, M.; MURPHY, K.; KUMAR, S.; SHI, L.; LEE, G. Effects of process variables on the powder yield of spray-dried trehalose on a laboratory spray-dryer. *European Journal of Pharmaceutics and Biopharmaceutics*, v. 59, n. 3, p. 565–573, 2005.
- MCCLEMENTS, D. J. Modulation of globular protein functionality by weakly interacting cosolvents. [s.l: s.n.]. v. 42
- MORISON, K. R.; TIE, S. The development and investigation of a model milk mineral fouling solution. *Trans IChemE*, v. 80, n. December, p. 326–331, 2002.
- NIEUWENHUIJSE, J. A. Sweetened Condensed Milk. In: *Reference Module in Food Science*. 1. ed. [s.l.] Elsevier Ltd, 2016. p. 869–873.
- RENHE, Í. R.; PEREIRA, D. B. C.; SÁ, J. F. O. DE; SANTOS, M. C. DOS; TEODORO, V. A. M.; MAGALHÃES, F. A. R.; PERRONE, Í. T.; SILVA, P. H. F. DA. Characterization of physicochemical composition , microbiology , sensory evaluation and microscopical attributes of sweetened condensed milk. *Food Science and Technology*, 2017.

- SCHUCK, P.; DOLIVET, A.; JEANTET, R. Analytical Methods for Food and Dairy Powders. 1. ed. [s.l.] John Wiley & Sons, 2012.
- SCHUCK, P.; DOLIVET, A.; MÉJEAN, S.; ZHU, P.; BLANCHARD, E.; JEANTET, R. Drying by desorption: A tool to determine spray drying parameters. *Journal of Food Engineering*, v. 94, n. 2, p. 199–204, 2009.
- SCHUCK, P.; ROIGNANT, M.; BRULÉ, G.; DAVENEL, A.; FAMELART, M. H.; MAUBOIS, J. L. Simulation of water transfer in spray drying. *Drying Technology*, v. 16, n. 7, p. 1371–1393, 1998.
- TANGUY, G.; PERRONE, I. T.; DOLIVET, A.; SANTELLANIA, A. C.; LEDUC, A.; JEANTET, R.; SCHUCK, P.; GAUCHERON, F. Calcium citrate insolubilization drives the fouling of falling film evaporators during the concentration of hydrochloric acid whey. *Food Research International*, v. 116, p. 175–183, 2019.
- TIMASHEFF, S. N. The Control of Protein Stability and Association by Weak Interactions with Water: How Do Solvents Affect These Processes. *Annual Review of Biophysics and Biomolecular Structure*, v. 22, n. 1, p. 67–97, 1993.
- WILDE, P. J.; NIÑO, M. R. R.; CLARK, D. C.; PATINO, J. M. R. Molecular Diffusion and Drainage of Thin Liquid Films Stabilized by Bovine Serum Albumin - Tween 20 Mixtures in Aqueous Solutions of Ethanol and Sucrose. *Langmuir*, v. 13, p. 7151–7157, 1997.
- WILLIAMS, A. M.; JONES, J. R.; PATERSON, A. H. J.; PEARCE, D. L. Milks and Milk Concentrates: Surface Tension Measurement. *International Journal of Food Engineering*, v. 1, n. 1, p. 1–8, 2005.
- WOUTERS, A. G. B.; FIERENS, E.; ROMBOUTS, I.; BRIJS, K.; BLECKER, C.; DELCOUR, J. A. Air-water interfacial properties of enzymatically hydrolyzed wheat gluten in the presence of sucrose. *Food Hydrocolloids*, v. 73, p. 284–294, 2017.
- ZACARCHENCO, P. B.; DENDER, A. G. F. VAN; REGO, R. A. *Brasil Dairy Trends 2020 - Tendências do mercado de produtos lácteos*. 1st. ed. Campinas: ITAL, 2017.

4. OTHER PUBLICATIONS DEVELOPED DURING THE DOCTORATE

5.1 PUBLISHED BOOK CHAPTER

1. DE CARVALHO, Antônio Fernandes, *et al.* Introdução à secagem do soro – diferenças entre secagem de leite e secagem de soro, composição do soro versus qualidade do produto final. In: **Química e Tecnologia do Soro de Leite**. INNÓVITE, 2020.
2. DE CARVALHO, Antônio Fernandes, *et al.* Estado vítreo e condições de operação do spray dryer para a secagem de soro. In: **Química e Tecnologia do Soro de Leite**. INNÓVITE, 2020.
3. DE CARVALHO, Antônio Fernandes, *et al.* Técnicas analíticas para o controle de qualidade e desenvolvimento de produtos na indústria de secagem de soro. In: **Química e Tecnologia do Soro de Leite**. INNÓVITE, 2020.

5. GENERAL CONCLUSIONS AND PERSPECTIVES

With the regular increase in demand for new healthier products, the industry not only has the need to review formulations, but also to pay attention to its industrial process. As seen in PAPER 1, when reducing the sucrose content of a product already widely known by the industry, its behavior changes. This happens simply by decreasing the content of an ingredient. A significant increase in fouling can occur and therefore requires further studies with different types of sweeteners, ingredients and/or additives that can be used in the food industry in order to ensure the sweetness of the traditional product and to verify if they will also present similar properties to those of sucrose, especially in the rate of formation and in the composition of the deposits formed.

Within the research and development studies, it becomes possible to carry out screening for preliminary evaluation of the products to be modified with a smaller amount of raw material and expenses. This is possible from the research done in PAPER 2, with the possibility of maintaining the physicochemical and also compositional characteristics using laboratory scale equipment before going to more specific tests in a falling film evaporator pilot. With this work, it was possible to establish the representative of two products (pure milk and milk added with sucrose) in two vacuum concentration evaporators with different principles, in laboratory scale in batch and in pilot scale acting continuously. Based on this work, it is possible to validate other concentrated products, such as whey, infant formula, and milk proteins. And also check other sweetened concentrated products, such as sweetened condensed milk with added whey. In addition, it is possible to carry out preliminary studies of parameters that can directly impact the drying step of products, such as viscosity.